

Examples Manual

LUSAS Version 14.6 : Issue 1

LUSAS
Forge House, 66 High Street, Kingston upon Thames,
Surrey, KT1 1HN, United Kingdom

Tel: +44 (0)20 8541 1999

Fax +44 (0)20 8549 9399

Email: info@lusas.com

<http://www.lusas.com>

Distributors Worldwide

Copyright ©1982-2011 LUSAS
All Rights Reserved.

Table of Contents

Introduction	1
Where do I start?	1
Software requirements.....	1
What software do I have installed?.....	1
About the examples.....	1
Teaching and Training version limits.....	2
Format of the examples	2
Running LUSAS Modeller	5
Creating a new model / Opening an existing model	6
Creating a Model from the Supplied VBS Files	7
The LUSAS Modeller Interface	8
Linear Elastic Analysis of a Spanner	11
Description	11
Modelling : Features.....	12
Modelling : Attributes.....	21
Running the Analysis.....	31
Viewing the Results.....	33
Arbitrary Section Property Calculation and Use	43
Description	43
Modelling.....	44
Nonlinear Analysis of a Concrete Beam	51
Description	51
Modelling.....	52
Running the Analysis.....	63
Viewing the Results.....	64
Contact Analysis of a Lug	71
Description : Linear Material	71
Stage 1 : Modelling : Linear Material.....	73
Running the Analysis : Linear Material	79
Viewing the Results : Linear Material	80
Nonlinear Contact.....	86
Description : Nonlinear Material	86
Stage 2 : Modelling : Nonlinear Material	86
Running the Analysis : Nonlinear Material	94
Viewing the Results : Nonlinear Material	95
Linear Buckling Analysis of a Flat Plate	103
Description	103
Modelling	104
Running the Analysis.....	109
Viewing the Results.....	110
Elasto-Plastic Analysis of a V-Notch	113
Description	113
Stage 1 : Modelling : Linear Material.....	115
Running the Analysis : Linear Material	121
Viewing the Results : Linear Material.....	122
Stage 2 : Modelling : Nonlinear Material	124
Running the Analysis : Nonlinear Material	127
Viewing the Results : Nonlinear Material	129
Stage 3: Modelling : Contact Analysis (Linear Material)	132

Introduction

Running the Analysis : Contact Analysis (Linear Material)	138
Viewing the Results - Contact Analysis (Linear Material)	139
Stage 4: Modelling : Contact Analysis (Nonlinear Material)	141
Running the Analysis : Contact Analysis (Nonlinear Material)	142
Viewing the Results : Contact Analysis (Nonlinear Material)	144
Modal Analysis of a Tuning Fork	147
Description	147
Modelling	148
Running the Analysis	160
Viewing the Results	161
Modal Response of a Sensor Casing	171
Description	171
Modelling	172
Running the Analysis	179
Viewing the Results	181
Thermal Analysis of a Pipe	191
Description	191
Modelling	192
Running the Analysis	197
Viewing the Results	198
Transient Thermal Analysis	200
Running the Analysis	203
Viewing the Results	203
Linear Analysis of a Composite Strip	205
Description	205
Modelling : Shell Model	206
Running the Analysis	217
Viewing the Results	219
Modelling : Solid Model	221
Running the Analysis	226
Viewing the Results	227
Damage Analysis of a Composite Plate	231
Description	231
Modelling	232
Running the Analysis	241
Viewing the Results	242
Mixed-Mode Delamination	245
Description	245
Modelling : Delamination Model	246
Running the Analysis	258
Viewing the Results	259

Introduction

Where do I start?

Start by reading this introduction in its entirety. It contains useful general information about the Modeller user interface and details of how the examples are formatted.

Software requirements

The examples are written for use with version 14.6 of LUSAS software products.

The LUSAS software product (and version of that product) and any product options that are required in order to run an example will be stated in a usage box like this:

For software product(s):	All (except LT versions)
With product option(s):	Nonlinear
Note: The example exceeds the limits of the LUSAS Teaching and Training Version.	

Note that Composite examples can be run in any software product if a Composite product option has been purchased. Similarly, LUSAS Analyst or LUSAS Composite products can run bridge or civil examples if a Bridge or Civil product option was purchased. The LUSAS Academic software product will run any example.

What software do I have installed?

To find out which software product(s), which version of that product, and which software options are installed and licensed for your use run LUSAS and select **Help > About LUSAS Modeller** and press the **Key Information** button to display a dialog that lists the facilities and options supported by your software license.

About the examples

The examples are of varying complexity and cover different modelling and analysis procedures using LUSAS. The first example in this manual contains detailed information to guide you through the procedures involved in building a LUSAS

model, running an analysis and viewing the results. This fully worked example details the contents of each dialog used and the necessary text entry and mouse clicks involved. The remaining examples assume that you have completed the fully worked example and may not necessarily contain the same level of information. It will benefit you to work through as many examples as possible, even if they have no direct bearing on your immediate analysis interests.

Teaching and Training version limits

Except where mentioned, all examples are written to allow modelling and analysis to be carried out with the Teaching and Training version of LUSAS which has restrictions on problem size. The teaching and training version limits are currently set as follows:

500 Nodes	100 Points	250 Elements	1500 Degrees of Freedom	10 Loadcases
---------------------	----------------------	------------------------	-----------------------------------	------------------------

Because of the modelling and analysis limits imposed by the Teaching and Training Versions some examples may contain coarse mesh arrangements that do not necessarily constitute good modelling practice. In these situations these examples should only be used to illustrate the LUSAS modelling methods and analysis procedures involved and should not necessarily be used as examples of how to analyse a particular type of structure in detail.

Format of the examples

Headings

Each example contains some or all of the following main headings:

- **Description** contains a summary of the example, defining geometry, material properties, analysis requirements and results processing requirements.
- **Objectives** states the aims of the analysis.
- **Keywords** contains a list of keywords as an aid to selecting the correct examples to run.
- **Associated Files** contains a list of files held in the \<Lusas Installation Folder>\Examples\Modeller directory that are associated with the example. These files are used to re-build models if you have problems, or can be used to quickly build a model to skip to a certain part of an example, for instance, if you are only interested in the results processing stage.

- ❑ **Modelling** contains procedures for defining the features and attribute datasets to prepare the LUSAS model file. Multiple model files are created in some of the more complex examples and these therefore contain more than one ‘Modelling’ section.
- ❑ **Running the Analysis** contains details for running the analysis and assistance should the analysis fails for any reason.
- ❑ **Viewing the Results** contains procedures for results processing using various methods.

Menu commands

Menu entries to be selected are shown as follows:

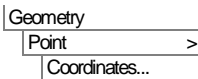

This implies that the **Geometry** menu should be selected from the menu bar, followed by **Point**, followed by the **Coordinates...** option.

Sometimes when a menu entry is referred to in the body text of an example it is written using a bold text style. For example the menu entry shown above would be written as **Geometry > Point > Coordinates...**

Toolbar buttons

For certain commands a toolbar button will also be shown to show the ‘short-cut’ option to the same command that could be used instead:



The toolbar button for the **Geometry > Point > Coordinates...** command is shown here.

User actions

Actions that you need to carry out are generally bulleted (the exception is when they are immediately to the right of a menu command or a toolbar button) and any text that has to be entered is written in a bold text style as follows:

- Enter coordinates of **(10, 20)**.

So the selection of a typical menu command (or the equivalent toolbar button) and the subsequent action to be carried out would appear as follows:

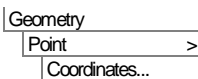

Enter coordinates of **(10, 20)**.

Selecting the menu commands, or the toolbar button shown will cause a dialog box to be displayed in which the coordinates **10, 20** should be entered.

Filling-in dialogs

For filling-in dialogs a bold text style is used to indicate the text that must be entered. Items to be selected from drop-down lists or radio buttons that need to be picked also use a bold text style.

For example:

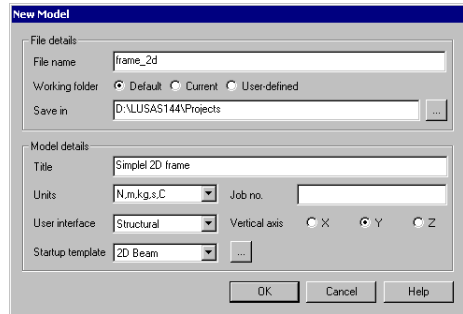

- In the New Model dialog enter the filename as **frame_2d** and click the **OK** button to finish.

Grey-boxed text

Grey-boxed text indicates a procedure that only needs to be performed if problems occur with the modelling or analysis of the example. An example follows:

Rebuilding a model

 Start a new model file. If an existing model is open Modeller will prompt for unsaved data to be saved before opening the new file.

- Enter the file name as **example**

To recreate the model, select the file **example_modelling.vbs** located in the **\<LUSAS Installation Folder>\Examples\Modeller** directory.

Visual Basic Scripts

Each example has an associated set of LUSAS-created VBS files that are supplied on the release kit. These are installed into the **\<Lusas Installation Folder>\Examples\Modeller** directory. If results processing and not the actual modelling of an example is only of interest to you the VBS files provided will allow you to quickly build a model for analysis. These scripts are also for use when it proves impossible for you to correct any errors made prior to running an analysis of an example. They allow you to re-create a model from scratch and run an analysis successfully. For more details refer to Creating a Model From The Supplied VBS files.

Modelling Units

At the beginning of each example the modelling units used will be stated something like this:

“Units used are N, m, kg, s, C throughout”

All units presented in the example are consistent units.

Icons Used

Throughout the examples, files, notes, tips and warnings icons will be found. They can be seen in the left margin.



Files. The diskette icon is used to indicate files used or created in an example.



Note. A note is information relevant to the current topic that should be drawn to your attention. Notes may cover useful additional information or bring out points requiring additional care in their execution.



Tip. A tip is a useful point or technique that will help to make the software easier to use.



Caution. A caution is used to alert you to something that could cause an inadvertent error to be made, or a potential corruption of data, or perhaps give you results that you would not otherwise expect. Cautions are rare, so take heed if they appear in the example.

Running LUSAS Modeller

- Start LUSAS Modeller from the start programs menu. Typically this is done by selecting:

Start > All Programs > LUSAS 14.x for Windows > LUSAS Modeller

- The on-line help system will be displayed showing the latest changes to the software.
- Close the on-line Help system window.

(LUSAS Academic version only)

- Select your chosen LUSAS product and click the **OK** button.

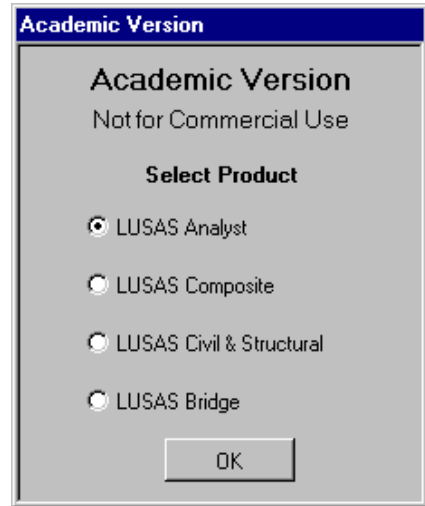

Creating a new model / Opening an existing model

When running LUSAS for the first time the LUSAS Modeller Startup dialog will be displayed.

This dialog allows either a new model to be created, or an existing model to be opened.



Note. When an existing model is loaded a check is made by LUSAS to see if a results file of the same name exists. If so, you have the option to load the results file on top of the opened model.



Note. When an existing model is loaded, that in a previous session crashed forcing LUSAS to create a recovery file, you have the option to run the recovery file for this model and recover your model data.

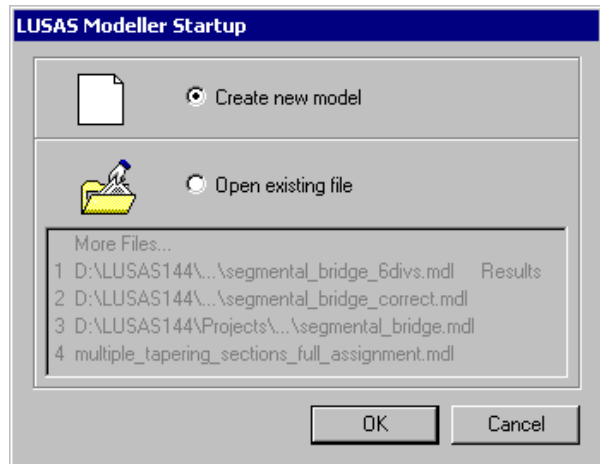

If creating a new model the New Model dialog will be displayed.

- Enter information for the new model and click the OK button.

Product specific menu entries for the selected software product in use e.g. **Bridge** or **Civil** will be added to the LUSAS Modeller menu bar.

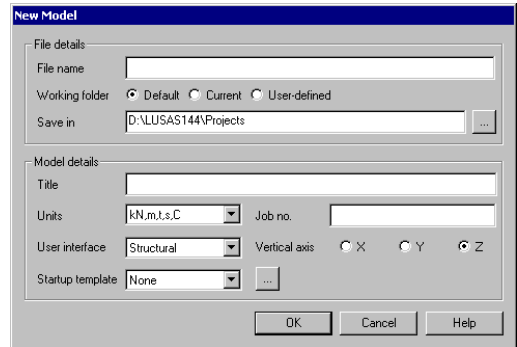

Creating a Model from the Supplied VBS Files

If results processing and not the actual modelling of an example is only of interest to you the VBS files provided will allow you to quickly build a model for analysis.

Proceed as follows to create the model from the relevant VBS file supplied:

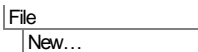

Start a new model file.

- Enter the file name as **example name** and click **OK**
- In general, ensure that the User interface selected is of the same type as the analysis to be carried out.

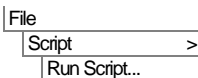

Select the file **example_name_modelling.vbs** located in the **\<LUSAS Installation Folder>\Examples\Modeller** directory.



Note. VBS scripts that create models automatically perform a **File > Save** menu command as the end.



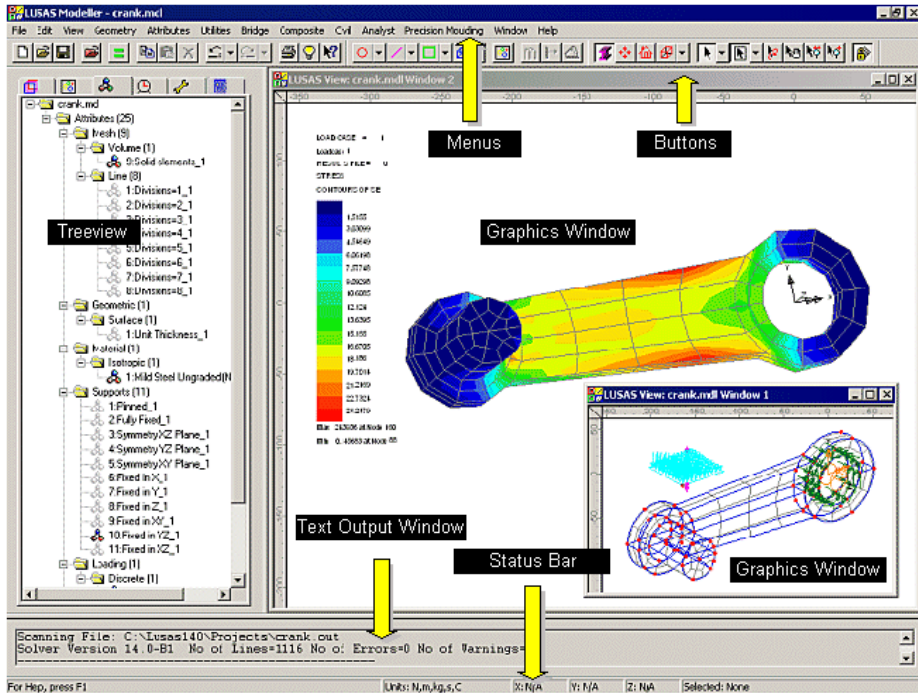





The LUSAS Modeller Interface



Modelling in LUSAS

A LUSAS model is graphically represented by geometry features (points, lines, surfaces, volumes) which are assigned attributes (mesh, geometric, material, support, loading etc.). Geometry is defined using a whole range of tools under the **Geometry** menu, or the buttons on the Toolbars. Attributes are defined from the **Attributes** menu. Once defined attributes are listed in the Treeview.

Treeview

Treeviews are used to organise various aspects of the model in graphical frames. There are a number of Treeviews showing Layers , Groups , Attributes , Loadcases , Utilities , and Reports . Treeviews use drag and drop functionality. For example, an attribute in the  Treeview can be assigned to model geometry by dragging the attribute onto an object (or objects) currently selected in the graphics window, or by copying and pasting an attribute onto another valid Treeview item as for instance, a group name, as held in the groups  Treeview.

Context Menus

Although commands can be accessed from the main menu, pressing the right-hand mouse button with an object selected usually displays a context menu which provides access to relevant operations.

Getting Help

LUSAS contains a comprehensive Help system. The Help consists of the following:

- The **Help** button  on the Main toolbar is used to get context-sensitive help on the LUSAS interface. Click on the **Help** button, then click on any toolbar button or menu entry (even when greyed out).
- Most dialogs include a **Help** button which provides information on that dialog.
- Selecting **Help > Help Topics** from the main menu provides access to all the Help files.



If the Help Contents, the Help Index and the Search facility are not shown when a help page is first displayed pressing the Show button will show these tabs in the HTML Help Window.

Linear Elastic Analysis of a Spanner

For software product(s):	All (except LT versions)
With product option(s):	None.

Description

A linear static analysis is to be carried out on the spanner shown.

The spanner is supported as though it were being used to turn a nut, and is loaded with a constant pressure load along the top edge of the handle.

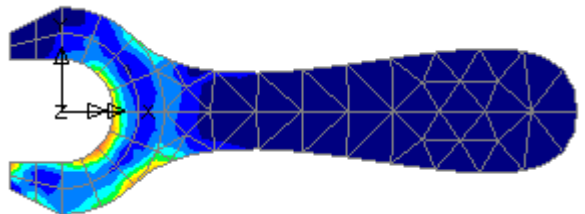

Units used are N, mm, t, s, C, throughout.

Keywords

2D, Linear, Elastic, Regular Meshing, Irregular Meshing, Copy, Rotate, Mirror, Transformation, Groups, Deformed Shape, Contour Plot, Principal Stress Vector Plot, Graph Plotting, Slice Section Results.

Objectives

The required output from the analysis is:

- A plot of the deformed shape.

- A plot of the equivalent stresses in the spanner.
- A graph showing the variation in equivalent stress where the handle meets the jaws.

Associated Files



- spanner_modelling.vbs** carries out the modelling of the example.

Modelling : Features

This section covers the definition of the features (Points, Lines and Surfaces) which together form the geometry of the spanner.

- The symmetry of the spanner will be used by firstly defining one half and then mirroring about a horizontal centre-line.
- One half of the jaws will be defined by three Surfaces using 3 different methods. One Surface will be defined simply by its bounding coordinates, a second by sweeping a Line through a rotational transformation and a third by copying the second Surface using a pre-defined rotation.
- One half of the handle will be defined using one Surface. It will be bounded by three Lines, one of which will be a cubic spline.
- Once the Surfaces have been defined, they will all be mirrored about the spanner centre-line.
- The features which make up the spanner will be divided into two Groups, the jaws and the handle, to make the assignment of attributes easier.

Running LUSAS Modeller

For details of how to run LUSAS Modeller see the heading *Running LUSAS Modeller* in the Examples Manual Introduction.



Note. This example is written assuming a new LUSAS Modeller session has been started. If continuing from an existing Modeller session select the menu command **File>New** to start a new model file. Modeller will prompt for any unsaved data and display the New Model dialog.

Creating a new model

- Enter the file name as **spanner**
- Use the **Default** working folder.
- Enter the title as **Spanner**
- Set the units as **N,mm,t,s,C**
- Select a **Structural** user interface.
- Select a **Standard** Startup template.
- Ensure the Vertical Axis is set to **Z**
- Click the **OK** button.

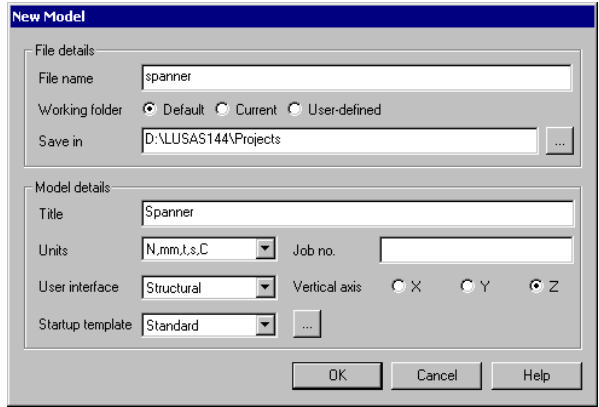

Note. Save the model as the example progresses. The Undo button  may be used to correct a mistake. The undo button allows any number of actions since the last save to be undone.

Modelling Geometry

LUSAS Modeller is a feature-based modelling system. The model geometry is defined in terms of features (Points, Lines, Surfaces and Volumes) which are later meshed to generate the Finite Element Model ready for solution. The features form a hierarchy, with Points defining Lines, Lines defining Surfaces and Surfaces defining Volumes.

Linear Elastic Analysis of a Spanner

Geometry
Surface >
Coordinates...



Enter coordinates of **(0, 20)**, **(-20, 20)**, **(-20, 30)** and **(0, 40)** to define the vertices of the Surface.



Note. Sets of coordinates are separated by commas or spaces. The **Tab** key is used to create new entry fields. The arrow keys are used to move between entries.

- Click the **OK** button to make the dialog disappear and generate the Surface as shown.



Note. If the Z ordinate is omitted zero is assumed.



Note. Confirmation that the Surface has been created is given in the message window.



Note. Cartesian, cylindrical or spherical coordinates systems may be used to define models. In this example Cartesian coordinates will be used throughout.

The right-hand vertical Line will be used to create a Surface by sweeping the line through a rotation of 45 degrees clockwise.

- Select the Line by moving the cursor over the Line shown and clicking the left-hand mouse button.

The line will change colour to show it has been selected.



Note. Feedback on the items currently selected is provided on the right-hand side of the status bar at the bottom of the display.

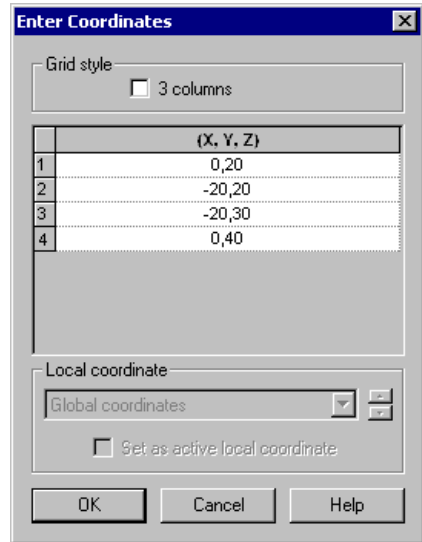

Select this Line

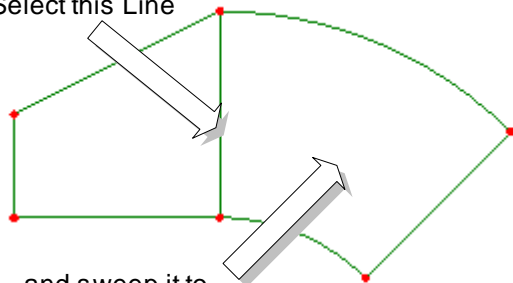

... and sweep it to form this Surface



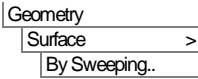

Select the **Rotate** option and enter **-45** for the angle of rotation about the **Z-axis**.

- Enter the attribute name as **Rotate 45 Clockwise**
- Click the **Save** button to save the dataset for re-use later.
- Click the **OK** button to sweep the Line clockwise through 45 degrees about (0,0,0) to create a Surface.



Note. Clockwise angles are negative and anti-clockwise angles are positive.

The Surface just drawn will now be copied by rotating it through a 45 degree rotation clockwise.

- Select the previously drawn Surface by clicking on it with the left-hand mouse button.

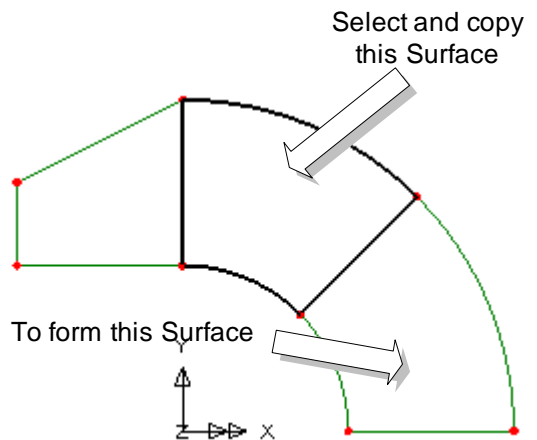
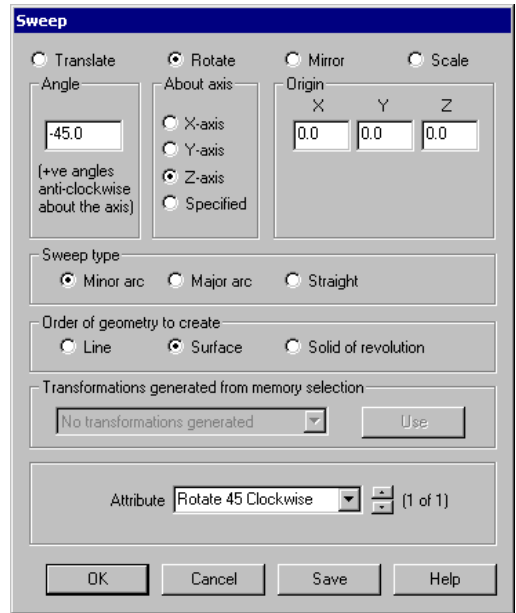

Linear Elastic Analysis of a Spanner

Geometry
Surface >
Copy...



Select the attribute **Rotate 45 Clockwise** from the drop down list.

- Ensure that the number of copies is set to **1**
- Click the **OK** button to copy the Surface, rotating it clockwise through 45 degrees.

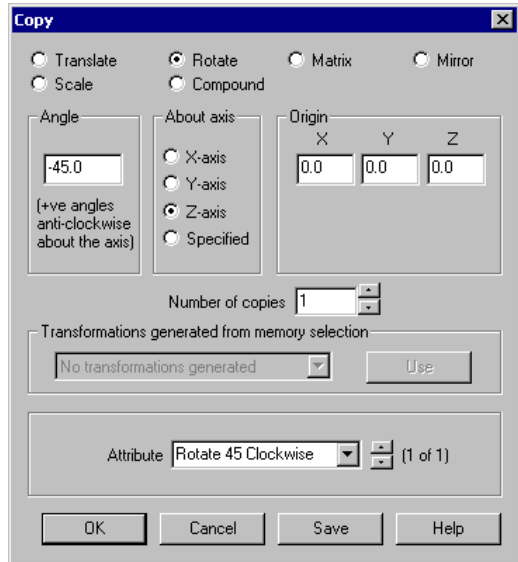

To define the top line of the handle of the spanner a cubic spline will be created.



Note. A cubic spline is a Line which passes through any number of Points. If required, the start and finish directions of the spline can be defined by specifying end-tangents (i.e. by specifying the directions of Lines at its ends).

In this example end-tangents are used to fix the start and finish directions of the spline so a construction Line must first be defined.

Geometry
Line >
Coordinates...



Enter coordinates of **(200, 0)** and **(200, -10)** to define the construction Line.

- Click the **OK** button to generate a vertical Line away from the existing Surfaces.

This Line will be used to specify the finishing direction of the cubic spline.



Note. When selecting features to define a cubic spline it is very important that the correct features are selected in a particular order. The Lines that define the start and finish directions of the spline are to be selected first, followed by the Points that define the start and end positions of the spline.

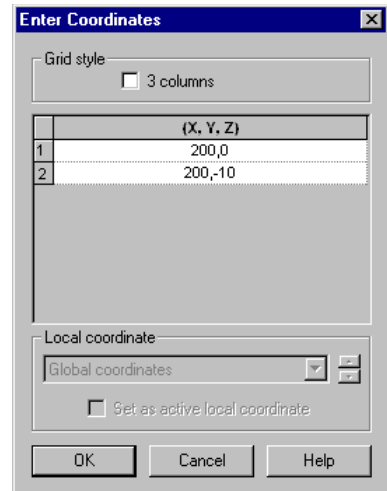

Defining a cubic spline

- Select the arc shown by moving the mouse over the arc and click the left-hand mouse button. (This arc defines the direction in which the spline starts).
- Hold the **Shift** key down to add additional features to the selection
- Select the construction Line defined earlier by moving the mouse over the Line shown and click the left-hand mouse button. (This Line defines the direction in which the spline ends).
- Continue holding the **Shift** key down to further add to the selection. Select the Point on the end of the first arc selected. (This defines where the spline starts).
- Still holding the **Shift** key down, select the Point on the end of the construction Line. (This defines where the spline ends).

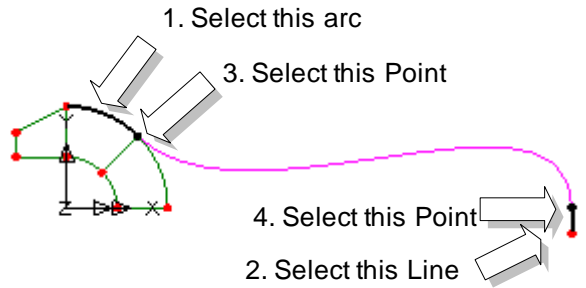

Click the **OK** button to generate a default cubic spline to form the handle of the spanner.

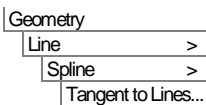

Note. Line directions can be seen by double-clicking on the Geometry entry in the Treeview and selecting the Line directions check box.

Once the spline is drawn correctly the construction Line is deleted.

- Drag a box around the construction Line by firstly moving the mouse above and to the left of the Line.
- Click the left-hand mouse button and holding it down

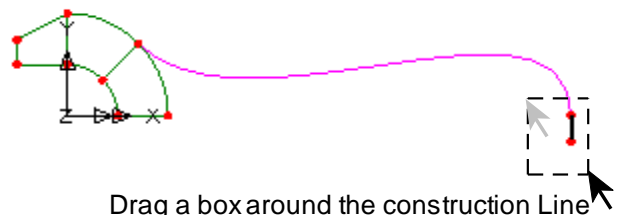

move the mouse to the right and down so that a box is shown which completely encloses the Line as shown. Release the left-hand mouse button. LUSAS will highlight the selected features.

Linear Elastic Analysis of a Spanner

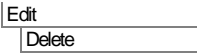



 Delete the selected features.

- Click the **Yes** button to delete the Lines
- Click the **Yes** button again to delete the Points.

The centre-line of the spanner can now be defined by joining the two unconnected points into a Line.

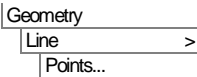
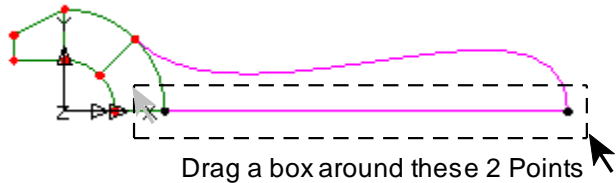
- Drag a box around the two Points on the centre-line of the spanner as shown



 A Line will be drawn between the points selected.

The Surface forming the handle of the spanner will now be defined by selecting the three Lines bounding the Surface.

- Select the 3 Lines which define the Surface of the handle in the order shown, ensuring the **Shift** key is held down to keep adding to the selection.

1. Select this Line

2. Hold Shift key down

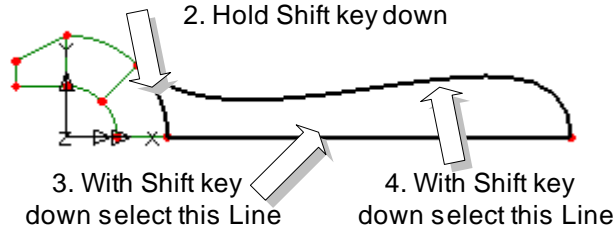

3. With Shift key down select this Line

4. With Shift key down select this Line

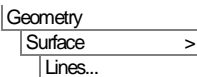

 To draw the Surface formed by the 3 lines selected.



Note. Selecting the Lines in this anti-clockwise order ensures that the local element axes of the Surface will be suitable for the applied face loading that will be applied later in the example. Selecting the Lines by dragging a box around them would not necessarily produce the same Surface axes.

Mirroring model information

Half of the model has now been defined. This half can now be mirrored to create the whole model. The first step in the process is to define a mirror plane.

- Select the 2 points shown, making sure the **Shift** key is held down in order to add the second Point to the initial selection.

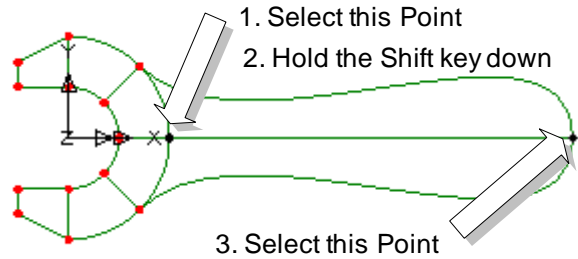

These Points define the axis about which the spanner will be mirrored.

Places the Points selected into memory.



Next, the Surfaces to be mirrored are to be selected. This will require the whole model to be selected.



Note. An alternative to dragging a box around all the features to select them is to press the **Ctrl** and **A** keys at the same time.

- Select the whole model by dragging a box around the features or by using the keyboard shortcut described previously.

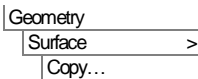

Select **Mirror – from Point 14 and Point 15** from the drop down list and click the **Use** button on the dialog to use the points previously stored in memory.

- Click the **OK** button to copy all of the Surfaces, mirroring them about the centre-line to give the model shown in the previous diagram.

If the model features have been mirrored successfully the Points held in memory may be cleared.

The Points are now cleared from memory.

This has completed the spanner geometry.

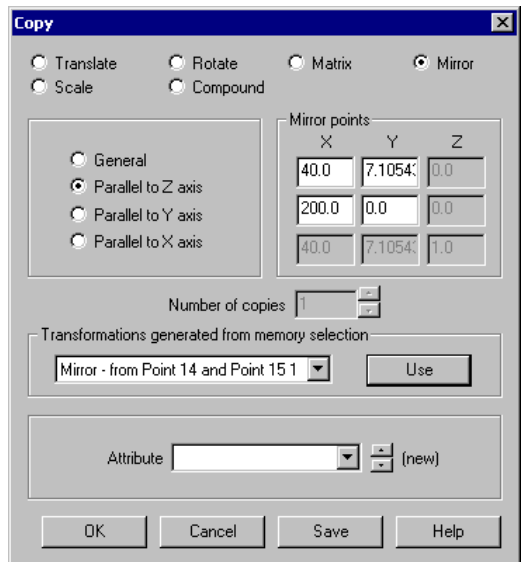
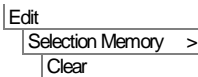



Using Groups



Tip. Model features can be grouped together to make assignment and viewing of model attributes easier.

In this example the Surfaces defining the jaws of the spanner will form one Group. The Surfaces defining the handle of the spanner will form another Group.

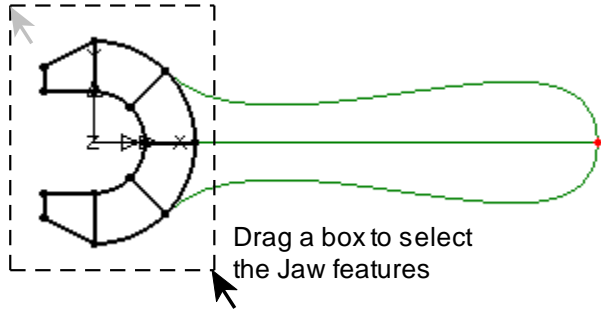

- Drag a box around the Surfaces representing the jaws of the spanner.

 Adds a New Group entry to the  Treeview for the features selected.



- Enter the group name as **Jaws** and click **OK** to finish defining the group.

- Drag a box around the Surfaces representing the handle of the spanner.

 Adds a New Group entry to the  Treeview for the features selected.

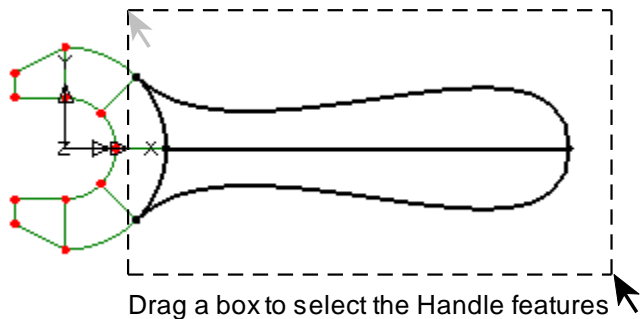

- Enter the group name as **Handle** and click **OK** to finish defining the group.

Modelling Features Recap

The features that form the 2-Dimensional representation of the spanner have been defined. In this section the following topics have been covered:

- How to define Points, Lines and Surfaces.
- How to define Lines by specifying the coordinates of their Points and by joining existing Points.

- How to define Surfaces by their bounding coordinates, by sweeping, and by copying.
- How to define a cubic spline.
- How to select features by using the Shift Key to add to a previous selection.
- How to select features by dragging a box around features to be selected.
- How to select all features in a model by pressing the Control and A keys.
- How to rotate and mirror model features.
- How to define groups of features.

Modelling : Attributes

Defining and Assigning Model Attributes

In order to carry out an analysis of the model various attributes must be defined and assigned to the model.

The following attributes need to be defined:

- The finite element **mesh** to be used.
- The **thickness** of the spanner.
- The **material** from which the spanner is made.
- The **supports** to be used.
- The **loading** on the spanner.



Note. LUSAS Modeller works on a define and assign basis where attributes are first defined, then assigned to features of the model. This can be done either in a step-by-step fashion for each attribute or by defining all attributes first and then assigning all in turn to the model.

- ❑ Attributes are first defined and are subsequently displayed in the Treeview as shown. Unassigned attributes appear 'greyed-out'.
- ❑ Attributes are then assigned to features by dragging an attribute dataset from the Treeview onto previously selected features.



Tip. Useful commands relating to the manipulation of attributes can be accessed by selecting an attribute in the Treeview, then clicking the right-hand mouse button to display a shortcut menu.

Defining the Mesh

The spanner will be meshed using both regular and irregular Surface meshes. A regular mesh is to be used for the jaws of the spanner. An irregular mesh will be used for the handle.

The number of elements in the regular Surface mesh will be controlled by defining line meshes on the Lines defining the boundary of the Surfaces. The number of elements in the irregular Surface mesh will be controlled by specifying an ideal element size. Other methods of controlling mesh density are also available.

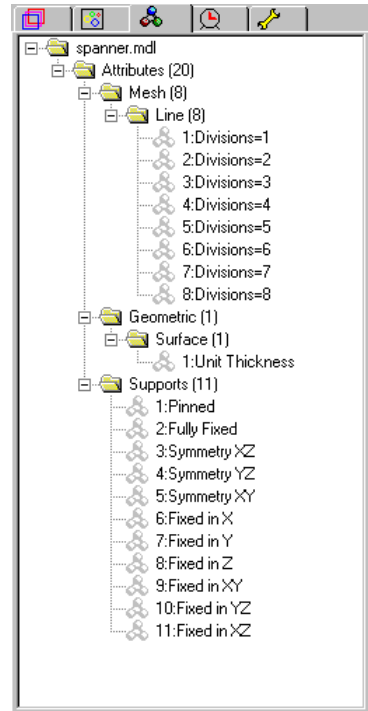

Defining a regular Surface mesh

Attributes
Mesh >
Surface...

- Select **Plane stress** elements, which are **Quadrilateral** in shape with a **Quadratic** interpolation order.
- Ensure that the **Regular Mesh** button is selected.
- Enter the attribute name as **Regular Plane Stress**
- Click the **OK** button to add the Surface mesh dataset to the  Treeview.

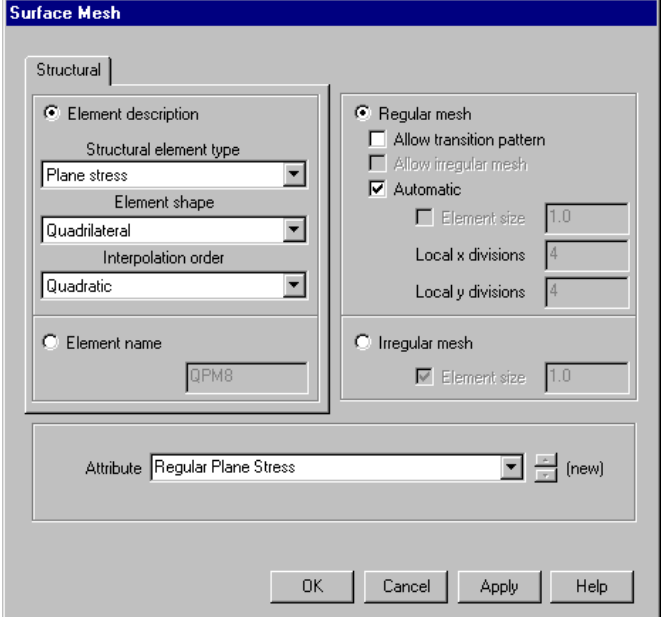

Surface Mesh

Structural

Element description

Structural element type: Plane stress

Element shape: Quadrilateral

Interpolation order: Quadratic

Element name: QPM8

Regular mesh

Allow transition pattern

Allow irregular mesh

Automatic

Element size: 1.0

Local x divisions: 4

Local y divisions: 4

Irregular mesh

Element size: 1.0

Attribute: Regular Plane Stress (new)

OK Cancel Apply Help

The mesh will be assigned to the model at a later stage.

Controlling mesh density

The lines currently defined have 4 divisions per line by default, but in this example only 2 divisions are required for the Lines defining the jaws. This can be done by either changing the default number of divisions per Line or by making use of Line mesh attributes. In this example, the default number of divisions will be changed.

File
Model Properties...

- Select the **Meshing** tab and set the **Default Line divisions** to **2**.
- Click the **OK** button.

Defining an irregular Surface mesh

- Select **Plane stress**, **Triangle**, **Quadratic** elements.
- Select the **Irregular mesh** button.
- Enter a **Specified** element size of **18**
- Enter the attribute name as **Irregular Plane Stress**.
- Click the **OK** button to add the Surface mesh attribute to the  Treeview.

The mesh will be assigned to the model at a later stage.

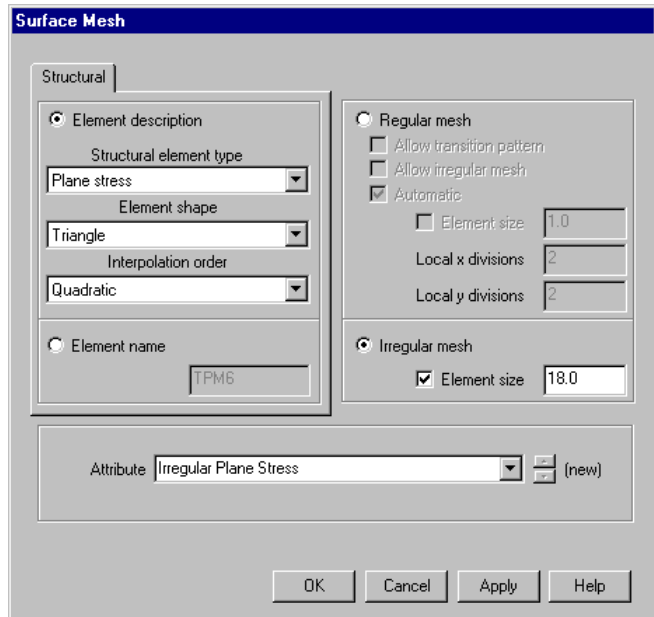

Defining the Thickness

So far the spanner has been defined in two dimensions. In order to give the spanner its thickness geometry attributes will be used. The jaws of the spanner are 15mm thick whilst the handle is 10mm thick. Two geometry attributes are required.

- Enter the thickness as **15**.
- Enter the Attribute name as **Thickness=15**
- Click the **Apply** button to add the geometry attribute to the  Treeview.

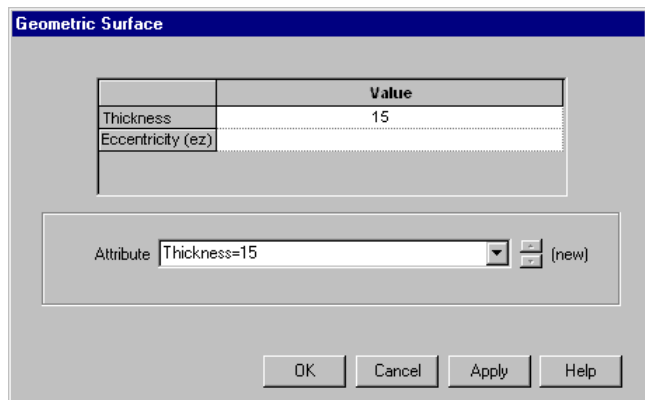





Note. The Apply button allows information for another attributes to be entered using the same dialog.

- Change the thickness to **10**
- Change the attribute name to **Thickness=10** and click the **OK** button to add the additional geometry attribute to the  Treeview.

Assigning a Surface mesh and Thickness to the Jaws

The Surface mesh and geometry attributes defined previously can now be assigned to the relevant features of the spanner. As an alternative to selecting features by dragging a box around them, the previously named Groups can be used.

- In the  Treeview, click the right-hand mouse button on the group name **Jaws** and select the **Select Members** option from the menu. If you already have some features selected click **Yes** to deselect them first.
- Drag and drop the Surface mesh attribute **Regular Plane Stress** from the  Treeview onto the selected Surfaces. Modeller will confirm the mesh assignment for each Surface in the text window.

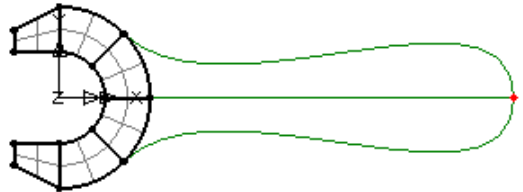

The element mesh for the jaws of the spanner will be drawn.

- Drag and drop the Surface geometry attribute **Thickness=15** from the  Treeview onto the selected Surfaces. The elements of the jaws remain selected.
- Click the left-hand mouse button in a blank part of the Graphics Window to deselect any previously selected model features. This shows that the geometric assignment has been visualised by default.



Select the fleshing on/off button to turn-off geometric property visualisation.

Assigning Surface mesh and Thickness to the Handle

- In the  Treeview, click the right-hand mouse button on the Group name **Handle** and select the **Select Members** option from the menu.

All Surfaces forming the group **Handle** will be selected.

Linear Elastic Analysis of a Spanner

- Drag and drop the Surface mesh attribute **Irregular Plane Stress** from the  Treeview onto the selected Surfaces defining the Handle.

LUSAS will draw the irregular element mesh for the handle of the spanner.



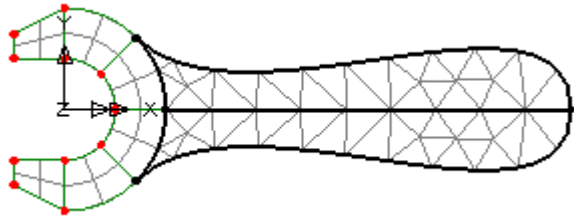

Note. The text output window will show messages relating to the radius of curvature for two of the elements created. These can be ignored for this example.



- Drag and drop the Surface geometry attribute **Thickness=10** from the  Treeview onto the selected Surfaces. Again confirmation of the assignment is provided in the text window.
- Click the left-hand mouse button in a blank part of the Graphics Window to deselect any previously selected model features.

Defining the Material

- Select the material **Mild Steel** of Grade **Ungraded** from the drop-down list and click **OK** to add the material attribute to the  Treeview.
- With the whole model selected (**Ctrl** and **A** keys together) drag and drop the material attribute **Iso1 (Mild Steel Ungraded)** from the  Treeview onto the selected features and assign to the selected surfaces by clicking the **OK** button.

Visualising Model Attributes



Note. Any attributes (i.e. geometry, material, supports etc.) assigned to the model can be checked visually to ensure that the correct item has been assigned to the correct part of the model. For example:

- Click the left-hand mouse button in a blank part of the Graphics Window to deselect any previously selected model features.
- In the  Treeview, click the right-hand mouse button on the **Thickness=15** material attribute name and select the **Visualise Assignments** option from the dialog.

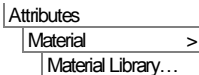

All features to which the **Thickness=15** attribute is assigned will be visualised.

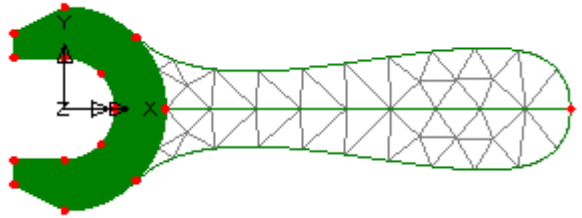

To turn-off the visualisation of the assignments, click the right-hand mouse button on the **Thickness=15** material attribute name in the  Treeview and select the **Visualise Assignments** option again from the dialog.



Note. This method can be used at any time during this example to check that selected attributes have been correctly assigned to the model.

Manipulating layers

At any time the layers displayed in the  Treeview may be re-ordered, hidden, removed or be re-added.

- Select the **Mesh** entry in the  Treeview and drag it down to sit beneath the **Geometry** entry. In the view window the mesh can now be seen drawn on top of the geometry.
- Click the right-hand mouse button on the **Mesh** entry in the  Treeview and select the **On/Off** option. The mesh will be hidden from the display.

Fleshing

Visualisation of assigned geometric attributes can also be seen using the fleshing option.



Select the fleshing on/off button to turn-on geometric property visualisation.



Select the isometric button to see the geometric visualisation on the elements.



Select the dynamic rotate button to view the spanner from the side. The difference in thickness between the handle and the jaws can be seen.



Select the fleshing on/off button to turn-off the geometric visualisation.



Select the Home button to return the model to the default view.



Reset to normal cursor mode.

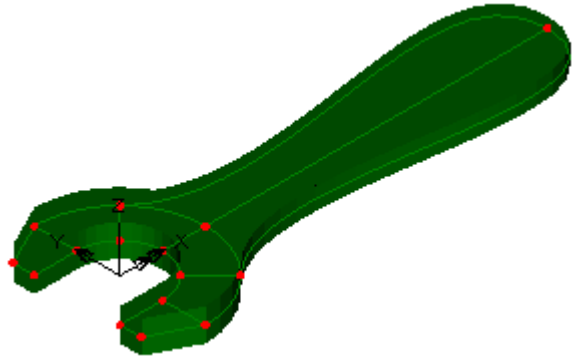

Supports

LUSAS provides the more common types of support by default. These can be seen in the  Treeview. Two support attributes are required, one which restrains movement in the X direction, and one which restrains movement in the Y direction.

Assigning the Supports

- Select the Point on the centreline of the spanner as shown to assign the support **Fixed in X**.
- Drag and drop the support attribute **Fixed in X** from the  Treeview onto the selected point.
- Click the **OK** button to assign the support to the Point selected.

Select these 2 Points for support 'Fixed in Y'

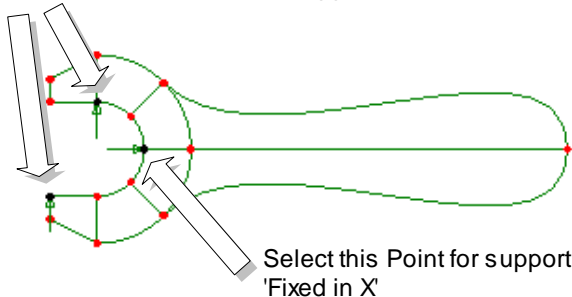

Select this Point for support 'Fixed in X'

The support will be visualised using an arrow symbol.

Select the 2 Points shown to assign the support **Fixed in Y**. Hold the **Shift** key down to add the second point to the initial selection.

- Drag and drop the support attribute **Fixed in Y** onto the selected points.
- Click the **OK** button to assign the support to the points selected.

The supports will be visualised using arrow symbols.

- Click the left-hand mouse button in a blank part of the graphics window to deselect any previously selected model features.

Defining the Loading

A pressure load is to be distributed evenly along the top edge of the handle.

- Select the **Face** option and click **Next**

Attributes
Loading... >

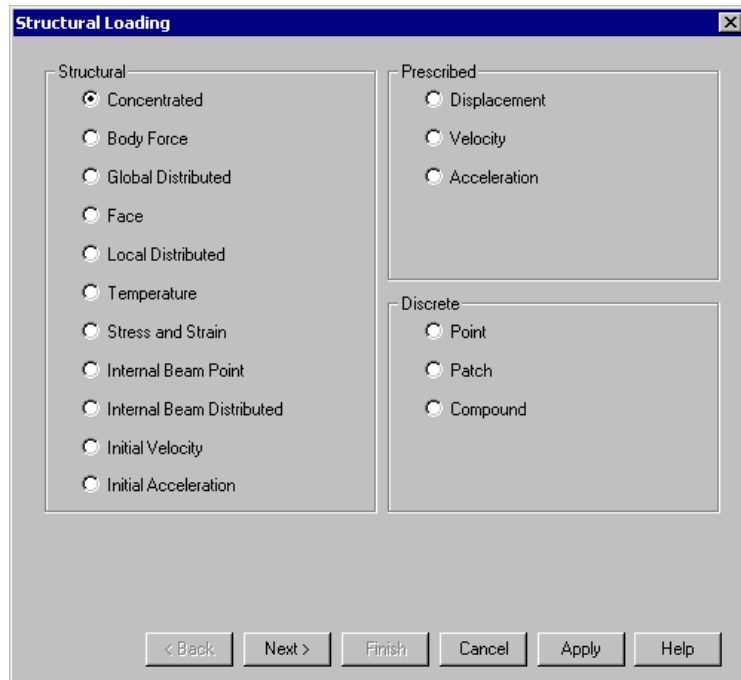

- Enter loading of **0.1** in the **y** direction.
- Enter the attribute name as **Face Load of 0.1**.
- Click the **Finish** button to add the loading attribute to the  Treeview.

Assigning the Loading

- Select the Line on the top edge of the spanner handle.
- Drag and drop the loading attribute **Face Load of 0.1** from the  Treeview onto the selected Line.
- Click the **OK** button to assign the loading to the Line selected.

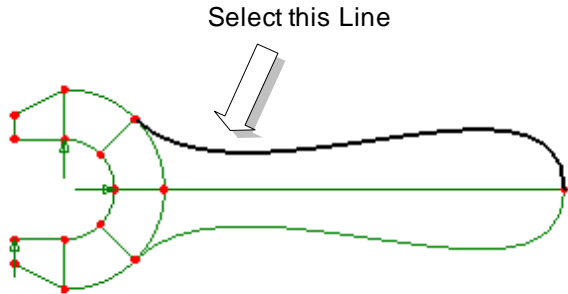

 **Note.** If the loading is displayed in the opposite direction to that shown the Surface forming the top half of the handle may be reversed as follows:

- Select the Surface defining the top-half of the spanner by dragging a box around it.

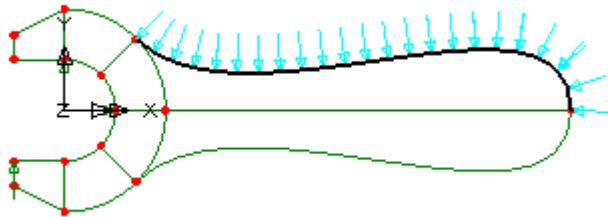

This will reverse the Surface axes and hence the direction of the loading.

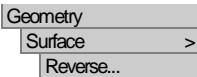

Saving the model

 To save the model file.



Modelling Attributes Recap

In this section, the attributes of the model were defined and assigned to the features.

- ❑ A regular Surface mesh with quadrilateral plane stress elements was defined and assigned to the jaws of the spanner. An irregular Surface mesh with

triangular plane stress elements and a fixed element size was defined and assigned to the handle of the spanner.

- Two geometry attributes were used to specify the spanner jaws and handle thickness.
- A material attribute specifying the properties of steel was defined and assigned to all Surfaces.
- Two support attributes were defined in order to simulate the spanner being used to turn a nut and a structural face load was applied to the top edge of the handle.
- Attributes assigned to the model were checked visually for correct assignment.

The model definition is now complete. The next step in the process is to run an analysis to solve the problem.

Running the Analysis

With the model loaded:

File
LUSAS Datafile...

The data file name of **spanner** will be automatically entered in the File name field.

With the **Solve now** option selected the LUSAS Solver will run an analysis.

The **Load results** option ensures that the results from the analysis are loaded on top of the existing model for immediate use in results processing.

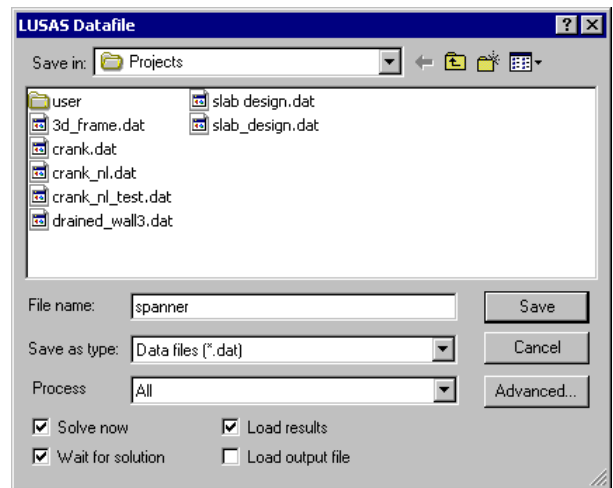

- Click the **Save** button to create the LUSAS data file from the model information.



Note. Pressing the Solve Now toolbar button  also runs an analysis and automatically uses the values shown on the LUSAS Datafile dialog.

If the analysis is successful...

The LUSAS results file (spanner.mys) will be added to the  Treeview.

In addition, 2 files will be created in the directory where the model file resides:



- ❑ **spanner.out** this output file contains details of model data, assigned attributes and selected statistics of the analysis.
- ❑ **spanner.mys** this is the LUSAS results file which is loaded automatically into the  Treeview to allow results processing to take place.

If the analysis fails...

If the analysis fails, information relating to the nature of the error encountered can be written to an output file in addition to the text output window. Any errors listed in the text output window should be corrected in LUSAS Modeller before saving the model and re-running the analysis. Note that a common mistake made when using LUSAS Modeller for the first time is to forget to assign particular attribute data (geometry, mesh, supports, loading etc.) to the model.

Rebuilding a Model

If it proves impossible for you to correct the errors reported a file is provided to enable you to re-create the model from scratch and run an analysis successfully.



- ❑ **spanner_modelling.vbs** carries out the modelling of the example.



 Start a new model file. If an existing model is open Modeller will prompt for unsaved data to be saved before opening the new file.

- Enter the file name as **spanner**

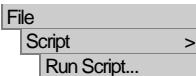

To recreate the model, select the file **spanner_modelling.vbs** located in the **<LUSAS Installation Folder>\Examples\Modeller** directory.





 Rerun the analysis to generate the results.

Viewing the Results

In this section the results produced by the analysis of the spanner will be viewed. There are a number of ways to do this in LUSAS, allowing you to choose the most appropriate way to present your results. For this example:

- A plot of the deformed mesh will be displayed and superimposed upon the undeformed shape for comparison.
- The principal stress vectors will be plotted.
- The von Mises stress contours for averaged stress values will be displayed.
- Peak values of von Mises stress will be marked.
- A graph will be produced showing the variation of stress along a slice section through the handle of the spanner.

Selecting the results to be viewed

If the analysis was run from within Modeller the results will be loaded on top of the current model and the first results loadcase is set active. This is signified by the results bitmap  in the  Treeview.

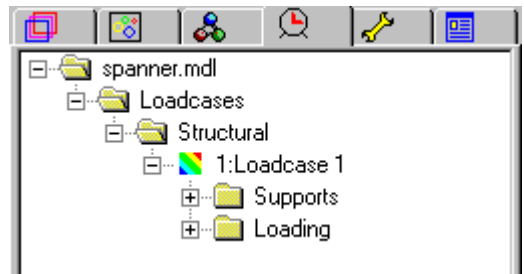

Using Page Layout Mode

The model was created using a Working Mode view which allows a model of any size to be created. Results could be viewed using this mode of operation, but in order to allow additional information to be added without obscuring the model, Page Layout Mode can be used instead.

View
Page Layout Mode...

The graphics window will resize to show an A4 size piece of paper.

File
Page Setup...

- Ensure that the **Landscape** option is selected and that left, right, top and bottom page **Margins** of **60, 10, 10, 10** respectively are set.
- Click the **OK** button.

This page layout view can also be saved for subsequent re-use with other models.

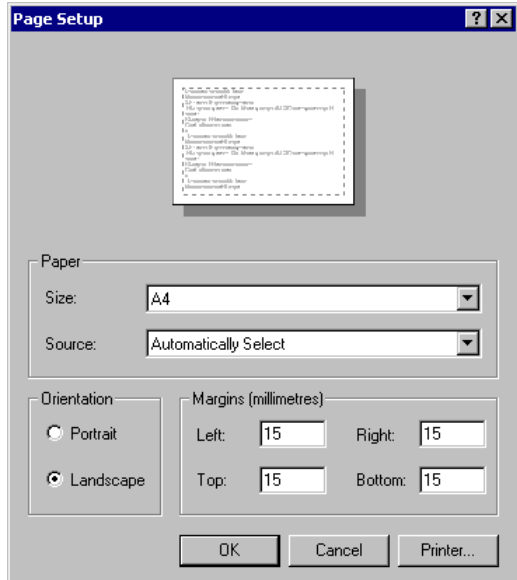

Window
Save View...

- Enter the view name as **Landscape Page Layout**.
- Click the **OK** button



Deformed Mesh Plot

To plot a deformed mesh the Geometry and Attribute layers will be hidden, the Mesh layer will be turned on and Deformed mesh layer will be added to the  Treeview.

- Click the right-hand mouse button on the **Geometry** entry in the  Treeview and select the **On/Off** option. The geometry will be hidden from the display.
- Repeat to turn off the Attributes layer.
- Turn on the **Mesh** layer.
- Double click on the **Mesh** layer in the  Treeview to display the mesh layer properties.

The mesh layer is to be plotted in green.

- Select  and a dialog will appear showing the range of pens and colours in use.

The mesh is currently drawn in a solid grey line style and is shown by the button with dashed outline.



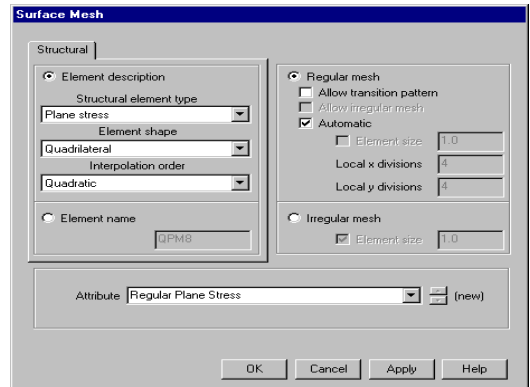
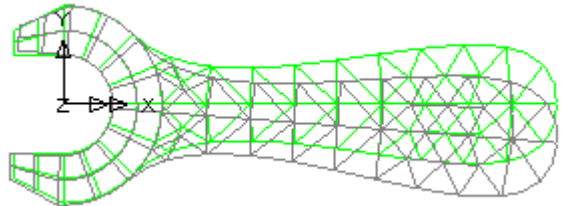

- Select the **Green** line pen.
- Click **OK** to redraw the mesh in the new colour.
- Double click on the **Deformed mesh** layer in the  Treeview to display the deformed mesh layer properties.
- Select the **Mesh** tab and ensure the **Show quadratic effects** button is selected. (This will draw the elements with curved rather than straight edges).
- Click the **OK** button to display the deformed mesh on top of the undeformed mesh layer.



Principal Stress Vector Plots

Principal stresses can be plotted as vectors with different colours being used to signify tension and compression.

The mesh layer is no longer required and it will now be hidden.

- Click the right-hand mouse button on the **Mesh** entry in the  Treeview and select the **On/Off** option.
- Click the right-hand mouse button in a blank part of the graphics window and select the **Vectors** option to add the vectors layer to the  Treeview.

Linear Elastic Analysis of a Spanner

The vector properties dialog will be displayed.

- Select **Stress - Plane Stress** vector results of **Principal** stresses from the entity drop down list.
- Click the **OK** button to display the vector plot with tension vectors shown in red and compression vectors shown in blue.

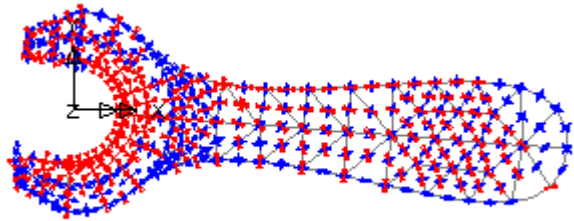
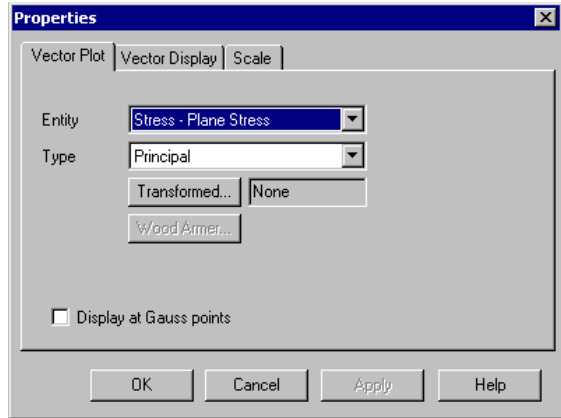

Creating New Windows

As an alternative to hiding, adding or removing layers from the  Treeview for each type of results to be displayed the multiple windows facility can be used.

A new window with default layers of Mesh, Geometry and Attributes will be created.

The graphics window will resize to show an A4 size piece of paper.

On the Load View dialog choose to load the view into the **Current Window** and select the **Landscape Page Layout** view name from the drop down list and click **OK**

- Turn on the **Mesh** layer
- Turn-off the **Geometry** and **Attributes** layers
- In the  Treeview Loadcase 1 will be set active by default.

Window
New Window

Window
Load view

Von Mises Stress Contour Plot

Contours of von Mises Stress (Equivalent Stress) may be plotted as lines or as colour-filled contour ranges. To display stress contours the contour layer needs to be added to the  Treeview.



- With no features selected, click the right-hand mouse button in a blank part of the active window and select the **Contours** option to add the contours layer to the  Treeview.

The contour plot properties dialog will be displayed.

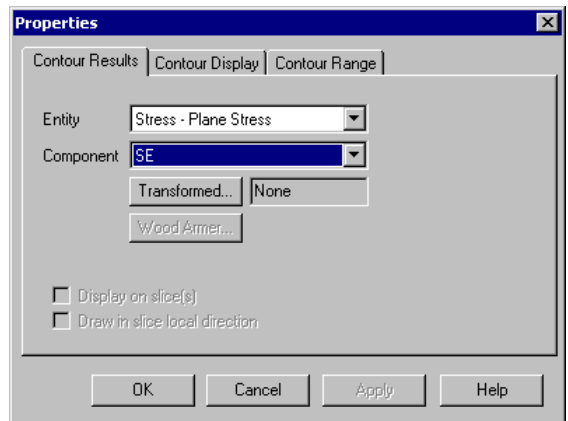
- Select **Stress - Plane Stress** contour results for the entity drop down list and equivalent stresses **SE** as the component.
- On the same dialog select the **Contour Display** tab and ensure that the **Contour key** button is selected.
- Click the **OK** button to display the contour plot of equivalent stress along with the contour key.



Re-ordering layers in the Treeview

The order of the layers in the  Treeview governs the order in which the layers are displayed. To see the mesh layer on top of the contours the mesh layer must be moved down the  Treeview list to a position after the contour layer.

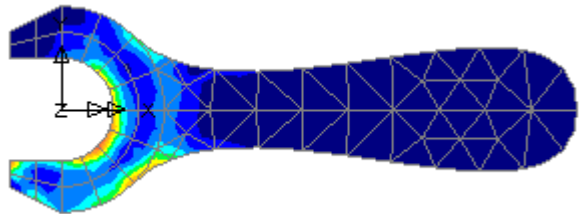

- In the  Treeview select the **Mesh** layer in Window 2, click the right-hand mouse button and select the **Move Down** option. (This can also be done by selecting the layer with the left-hand mouse button and dragging and dropping a layer name on top of another layer name).

The mesh layer will then be displayed on top of the contour layer.

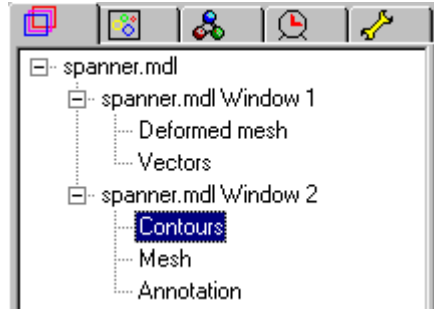

Moving information on the annotation layer

Annotation layer objects such as the contour key may be moved after their initial placement.

- To select the contour key click on the key with the left-hand mouse button.
- Now press and hold the left-hand mouse button down, drag the key to a suitable position on the screen, and release the mouse button to reposition it.

Marking Peak Values

- Deselect the contour key by clicking the left-hand mouse button in a blank part of the graphics window.
- With no features selected click the right-hand mouse button in a blank part of the graphics window and select the **Values** option to add the values layer to the  Treeview.

The values properties dialog will be displayed.

- Select **Stress - Plane Stress** contour results from the entity drop down list and Equivalent stresses **SE** as the component.
- On the same dialog, select the **Values Display** tab and set **Maxima** values to display the top **1%** of results. (This will show the peak stress value)
- Click the **OK** button to display the contour plot with peak values marked.

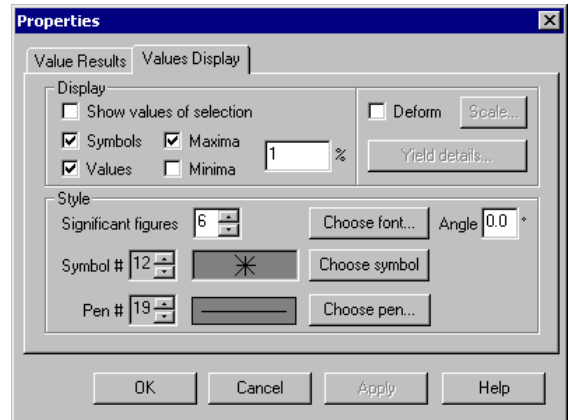

 Use the Zoom in button to enlarge the view of the spanner to check the number obtained.

 Use the Home button to both re-size the view and ensure the model lies in the XY plane in readiness for creating a slice section of results.

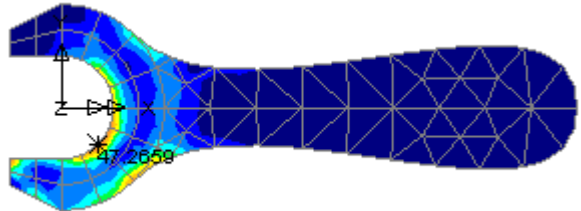

Creating a Slice Section of Results

- Ensure the **Snap to grid** button is selected and a grid size of **10** is specified.
- Click the **OK** button.

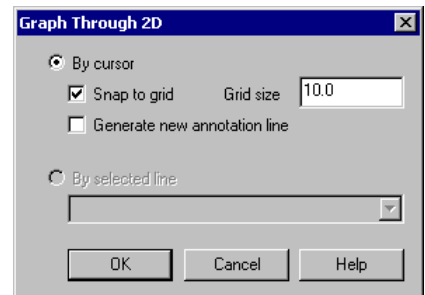

Utilities

Graph Through 2D...

Linear Elastic Analysis of a Spanner

- Click and drag the cursor as shown (at the X=40 location) to define a section slice through the handle of the spanner where it joins the jaws.

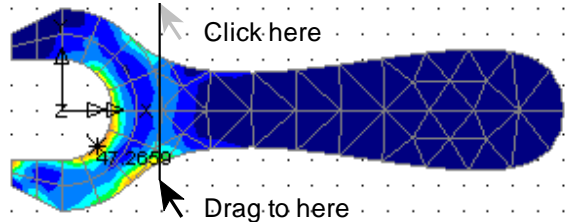

This operation leads directly on to creating a graph using the graph wizard...

Selecting the Slice Data Results to be Plotted

In this example a graph is to be plotted of the variation in stress through the specified section of the spanner. The X axis results of distance through the spanner have been defined by the section slice. The Y axis results now need to be specified.

- Select **Stress - Plane Stress** results from the entity drop down list and **Equivalent Stress SE** from the component drop down list.
- Click the **Next** button to define the Y axis results.

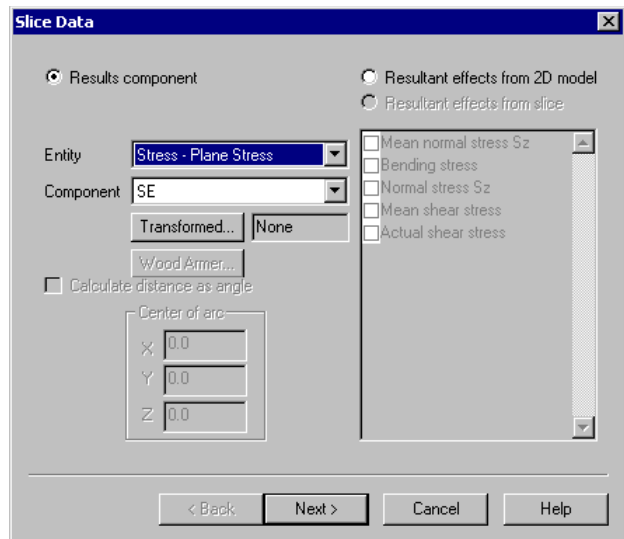

Title information for the graph is now to be added.

- Enter the graph title as **Stress at neck section**
- Enter the X axis label as **Distance along section**
- Enter the Y axis label as **Equivalent Stress (N/mm²)**
- Deselect the **Show symbols** button.
- Click the **Finish** button to display the graph in a new window and show the values used in an adjacent table.

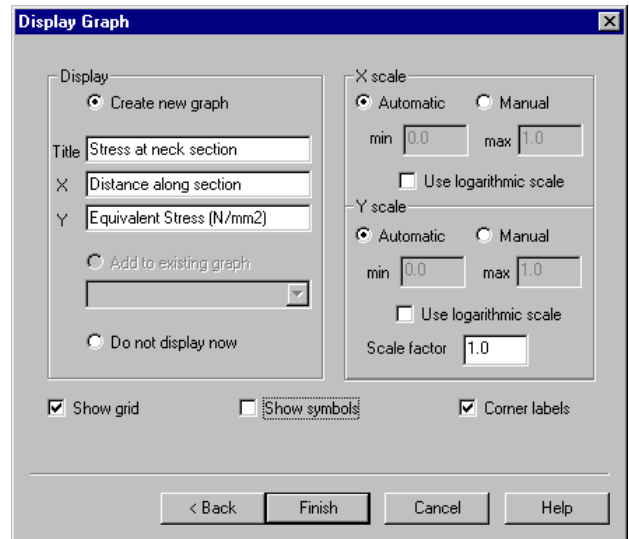

Note. If the graph title or axes labels are left unspecified Modeller will use default names.



To see the graph at the best resolution enlarge the window to a full size view.

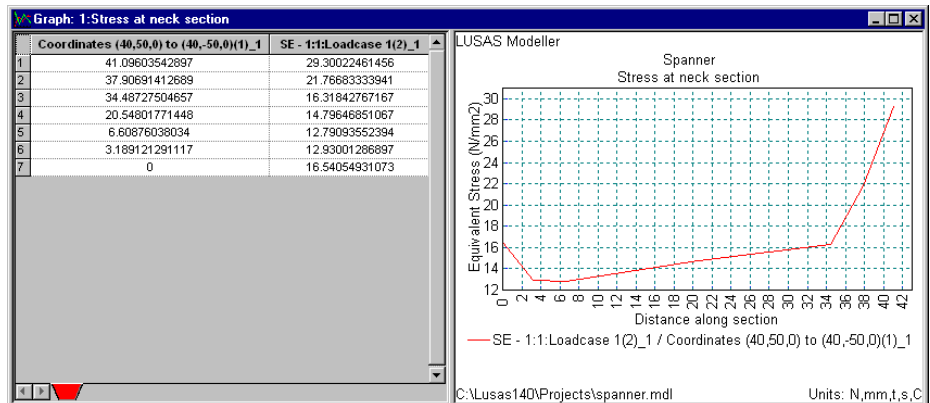

Note. The properties of the graph may be modified by clicking on the graph with the right-hand mouse button and selecting the Edit Graph Properties option.



To exit from the Graph Through 2D option click the **Select Any** cursor button.

Linear Elastic Analysis of a Spanner

The grid will be removed.

This completes the example.

Arbitrary Section Property Calculation and Use

For software product(s):	All (except LT versions)
With product option(s):	None.

Description

The section properties of an arbitrary shaped box section are to be computed and saved in a user library. Section geometry is supplied as a DXF file.

Units of N, mm, t, s, C are used.

Objectives

The required output from the analysis consists of:

- Section Properties of a box section

Keywords

Section Properties, Arbitrary Section, Holes, Local Library, Server Library

Associated Files



- box_section.dxf** DXF file containing geometry of section.

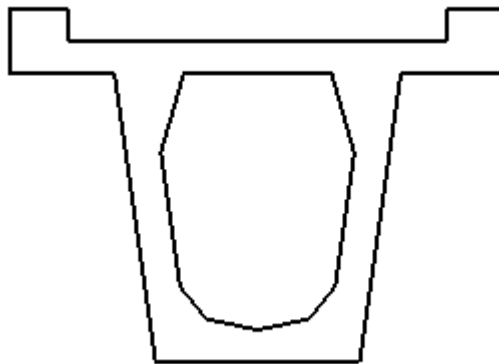

Modelling

Running LUSAS Modeller

For details of how to run LUSAS Modeller see the heading *Running LUSAS Modeller* in the Examples Manual Introduction.



Note. This example is written assuming a new LUSAS Modeller session has been started. If continuing from an existing Modeller session select the menu command **File> New** to start a new model file. Modeller will prompt for any unsaved data and display the New Model dialog.

Creating a new model

- Enter the file name as **box_section**
- Use the **Default** working folder.
- Enter the title as **Box Section**
- Select units of **N,mm,t,s,C** from the drop down list provided.
- Set the User Interface to **Structural**
- Set the Startup template as **None**
- Ensure the vertical axis is set to **Z**
- Click the **OK** button.

Discussion

The arbitrary section property calculator within LUSAS Modeller computes the section properties of any open or closed section. Cross-sections are created either as a single regular or irregular surface, or as a group of surfaces. Any number of holes can be included in a surface but any holes in a section must be defined as separate surfaces and placed into a Group named **Holes**. When calculating cross-sectional properties the extent of a hole must be defined using a surface because the hole or holes will also be meshed by the section property calculator in order to generate the section properties for the complete section. Fibre definitions (positions on the cross-section at which stresses or values can be plotted when viewing results) are also created for each drawn section at the time of section property calculation.



Note. 2D cross-sections for section property calculation must be defined in the XY plane.

Feature Geometry

File
Import Geometry...

- Locate the **box_section.dxf** file in the **\<Lusas Installation Folder>\Examples\Modeller** directory and click the **Import** button to read in the DXF file and create the cross section geometry as shown below.

Defining holes within a section

This is done by first defining a surface that represents the total extent of the box-section, then defining a surface that represents the void or hole, and then selecting both the surrounding and inner surface to create the hole in the bounding surface.

- Drag a box around the whole model

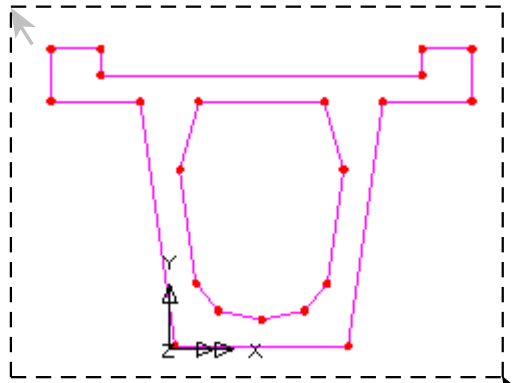

Box select the whole model

Geometry
Surface >
Lines...



Create an outer Surface from the selected Lines.

- Now, drag a box around the only the lines defining the void.

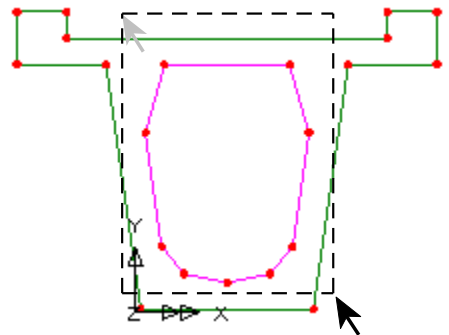

Box select the lines defining the void

Geometry
Surface >
Lines...



Create an inner Surface from the selected Lines.

Arbitrary Section Property Calculation and Use

- Select the outer Surface of the box-section followed by the inner Surface representing the void. (Use the **Shift** key to pick the inner Surface to add it to the initial selection)

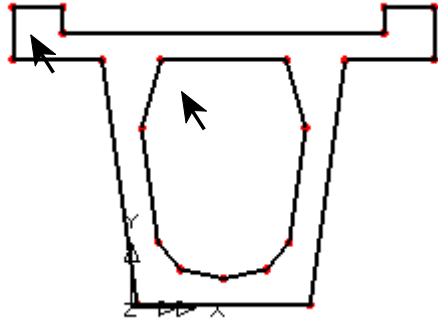

Select these two surfaces

- On the Create Holes dialog, **de-select** the option **Delete geometry defining holes**. This ensures that the geometry defining the void remains as a Surface in its own right. This is important for section property calculation.

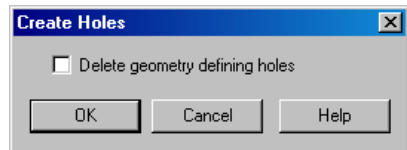

A new singular Surface will be created, containing a void which itself is a Surface. This new surface containing the hole can be seen / checked by clicking in a blank part of the Graphics Window and then re-selecting the outer surface.



Caution. Failing to de-select Delete geometry defining holes on the Create Holes dialog will result in incorrect section properties being calculated.

Now create a Group called Holes

With only the Surface representing the hole selected:



Create a group named **Holes**

Save the cross-section model for any future modifications or for use with the definition of any additional fibre locations.

The section properties can now be calculated as follows:

Calculating Section Properties

Utilities
 Section Property
 Calculator >
 Arbitrary Section...

- Select the **Add to local library** option.
- Click the **Apply** button, and after a short wait the calculated section properties will be displayed in the greyed boxes on the right-hand side of the form.
- Click **Cancel** to close the dialog.

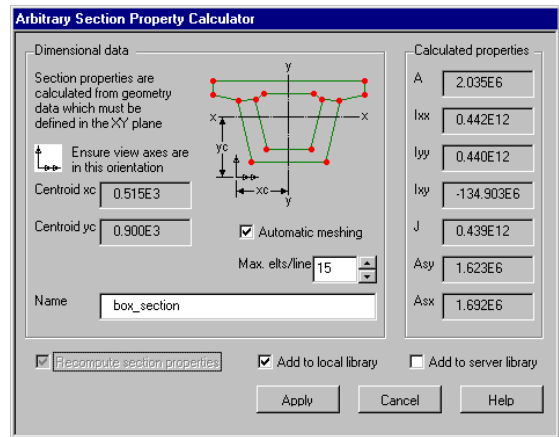

Note. There is no need to compute the section properties in the units they are to be used in the analysis model because units conversion is carried out when the section properties are extracted from the section library if it is found to be required.



Note. Section properties may be added to local (user) or server (all users) section property libraries by selecting the appropriate option(s) prior to selecting the **Apply** button. Alternatively you can deselect the 'Recompute section properties' option after selecting the 'Add local library' or 'Add server library' options. By default the model name is entered as the Section Name. This can be modified if required.

Notes on the automatic meshing used

The mesh used to compute the properties of each of the surfaces (and the holes) is displayed in the graphics window. The Group named **Holes** may be may invisible should this be required for section printing purposes.

By default an element size is selected which will assign 15 elements to the longest side and a minimum of 2 elements is applied to the shorter sides. This mesh may be adjusted by

deselecting the automatic mesh check box and changing the mesh size in the  Treeview. Alternatively, the maximum element on the longest side may be adjusted by changing the 'Max elts/line' option as required prior to selecting the **Apply** button. As with all finite element models the more elements used the more accurate the results

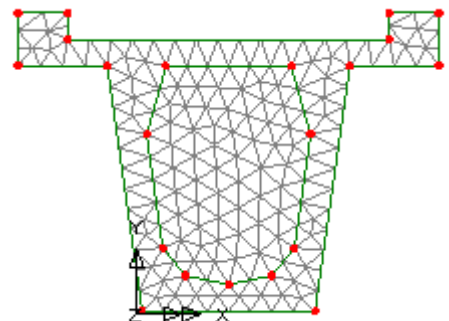

Arbitrary Section Property Calculation and Use

but the slower the calculation. A good compromise of 2 elements across all thin sections has been found to provide reasonable results without using excessive computation time.

Viewing and using sections in the user library

Create a new model called **Test** and select units of **N,mm,t,s,C** from the drop down list provided. Click **OK**.

- Select **User Sections** from the top-right drop-down on the dialog
- Browse for, and select the **box_section** name. The basic section will be visualised.
- Select the **Visualise** button and the fibre definitions will be seen. Click **Close**

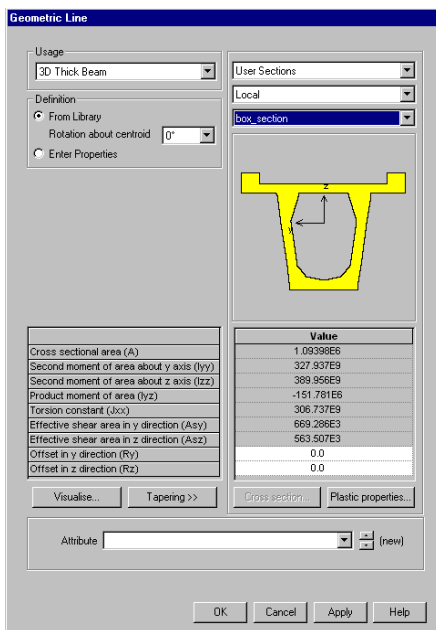

Visualisation of local library item

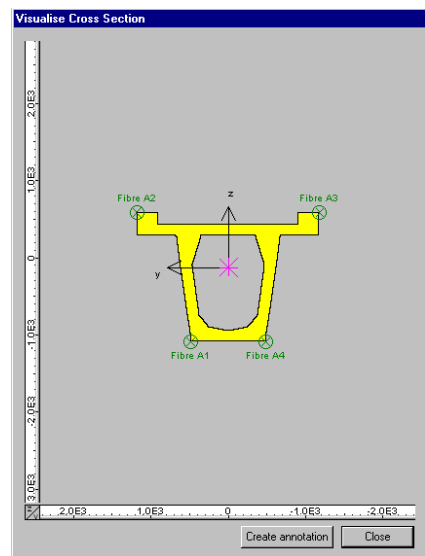

Fibre locations can be used to calculate beam stress results for plotting force and moment diagrams. LUSAS automatically creates one for every extreme point on a section.

- On the Geometric Line dialog, select the **Enter Properties** option then select the **Cross-section** button. Additional fibre locations can be added manually to the library item by clicking in the Fibre locations area and pressing the **TAB** key until a new line is created, and then entering the coordinate of the fibre location required.



Tip. If additional fibre locations are required on the section use Modeller to obtain the properties of any additional points on the saved model and enter the point coordinates in the manner described above.

Finally, to add the local library section to the Attributes Treeview (for subsequent assignment to beams in the model) press the **OK** button.

This completes the example.

Fibre locations for post-processing	
Fibre name	Local zy coordinates
1 A1	(-960.795, 484.75)
2 A2	(709.202, 1.18038E3)
3 A3	(709.202, -1.17962E3)
4 A4	(-960.795, -485.255)

Number of integration points for the current section:

Default

Specify

Upper and lower sides: 2

Left and right sides: 2

Quadrilateral cross section properties	
	Local zy coordinates
Lower Left Corner	385.981, 677.147
Upper Left Corner	(364.373, 363.142)
Upper Right Corner	(28.1615, 459.354)
Lower Right Corner	(-8.76358, 620.755)

1 01 29 New Insert Delete Visualise...
OK Cancel Help

Nonlinear Analysis of a Concrete Beam

For software product:	Any Plus version.
With product options:	Nonlinear.

Description

A nonlinear plane stress analysis is to be carried out on a model of a reinforced concrete beam.

The reinforcement is provided in the lower face of the beam and has a total cross-sectional area of 400 mm^2 . The superposition of nodal degrees of freedom assumes that the concrete and reinforcement are perfectly bonded. It is assumed that the self-weight of the beam is negligible compared with the applied load and that the effects of any shear reinforcement can be ignored.

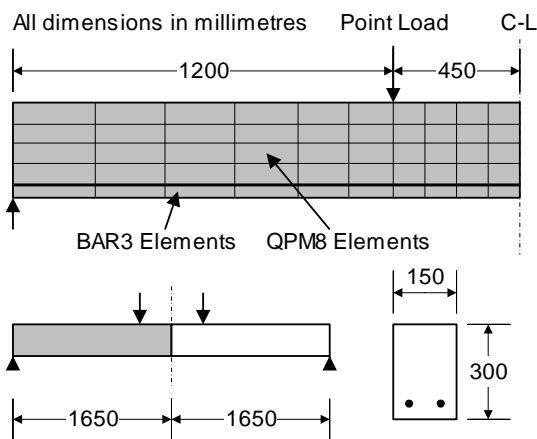

Due to the symmetrical nature of the problem, only the left-hand span of the beam is modelled. The beam is simply supported at the left-hand end with a symmetry support at the right-hand axis of symmetry. A concentrated vertical load is applied to the top of the beam 1200mm from the left-hand end. The concrete section is represented by plane stress (QPM8) elements, and the reinforcement bars are represented by bar (BAR3) elements. A nonlinear concrete cracking material model will be applied to the plane stress elements and a von Mises plastic material will be applied to the reinforcement bars.

Units of N, mm, t, s, C are used throughout.

Objectives

The behaviour of the beam under cracking/yielding is to be examined by producing the following:

- A Deformed Mesh Plot showing the final deformed shape.**
- A Load Displacement Graph** for the top node on the axis of symmetry of the beam.
- Stress contour plot** showing the stress distribution in the beam.
- Crack pattern plot** showing the crack patterns produced.
- Animation of stresses and crack patterns** for selected load increments.
- A graph of variation in stress** through selected slice sections through the beam.

Keywords

2D, Plane Stress, Bar Elements, Nonlinear Concrete Model, Element Selection, Concrete Cracking, Steel Reinforcement, Groups, Crack Patterns, Animation, Graphing, Load Displacement Curve, Slice Sections

Associated Files



- beam_nl_modelling.vbs** carries out the modelling of the example.

Modelling

Running LUSAS Modeller

For details of how to run LUSAS Modeller see the heading *Running LUSAS Modeller* in the Examples Manual Introduction.



Note. This example is written assuming a new LUSAS Modeller session has been started. If continuing from an existing Modeller session select the menu command **File>New** to start a new model file. Modeller will prompt for any unsaved data and display the New Model dialog.

Creating a new model

- Enter the file name as **beam_nl**
- Use the **Default** working folder.

- Enter the title as **Nonlinear Concrete Beam**
- Set the units as **N, mm, t, s, C**
- Select a **Structural** user interface.
- Select the model startup template **Standard**
- Select the **Vertical Y Axis** option.
- Click the **OK** button.



Note. Save the model regularly as the example progresses. Use the Undo button to correct any mistakes made since the last save was done.

Defining the Geometry

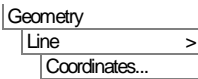

 Enter coordinates of **(0, 0)**, **(1200, 0)** and **(1650, 0)** to define two Lines representing the bottom of the left hand span of the beam. Click the **OK** button to finish.

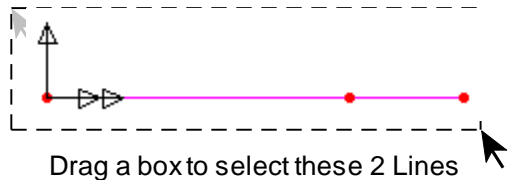

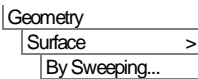

- Select both Lines just drawn by dragging a selection box around them.

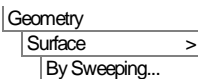
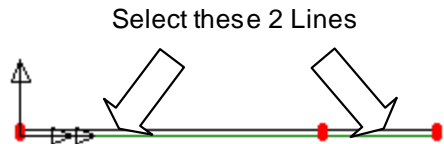

 Enter a translation value of **25** in the **Y** direction to create the Surface which represents the concrete cover from the face of the beam to the centreline of the reinforcement.

- Click the **OK** button.
- Select the upper Lines of both of the Surfaces just drawn as shown.



 Enter a translation value of **275** in the **Y** direction to create the Surface which represents the extent of the concrete above the centreline of the reinforcement.

- Click the **OK** button.

Nonlinear Analysis of a Concrete Beam

The model should appear as shown.



Defining Groups

To simplify the assignment of model attributes certain model features will be grouped together to allow selection by name in the  Treeview as opposed to selection by cursor in the graphics window. The 2 Lines representing the reinforcement bars are to be grouped together:

- Ensure the 2 Lines are still selected as shown.



Enter **Bars** for the group name.

- Click the **OK** button to complete creation of the group.

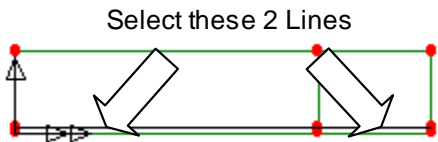

The Surfaces representing the concrete are to be grouped together.

- Holding-down the **S** key, (and noting that the cursor changes to show the type of feature that will be selected) drag a box around the whole model to select only the Surfaces defining the concrete.

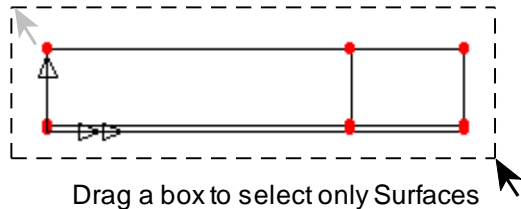

Enter **Concrete** for the group name. Click the **OK** button to complete creation of the group.

Note. In this example, model attributes will be defined but not assigned to the model straight away. They will be assigned to the model later by making use of the Groups facility.



Defining the Mesh Reinforcement Bars

Separate mesh datasets need to be defined for the reinforcement bars and the concrete. For the reinforcement bars a uniform mesh is to be used to the right of the applied load and a graded mesh is to be used on the horizontal lines to the left of the applied load.

The reinforcement bars will be modelled using Line meshes.

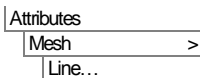
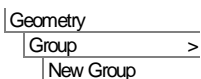
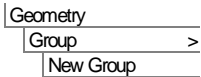
- Set Generic element type to **Bar**, Number of dimensions to **2 dimensional** and Interpolation order to **Quadratic**





- Ensure the **Number of divisions** is set to **4**
- Enter the attribute name as **Bar Elements - Divs=4**
- Click the **Apply** button to create the attribute in the  Treeview and leave the dialog visible to allow additional datasets to be defined.
- Change the **Number of divisions** to **6** and click the **Spacing** button.
- Select a **Uniform transition** ratio of first to last element of **2** and click **OK**
- Change the attribute name to **Bar Elements - Divs=6 graded**
- Click the **OK** button to finish to add the attribute to the  Treeview.

Defining the Mesh Concrete

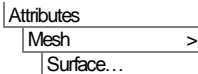
The concrete will be modelled using a Surface mesh with Line mesh divisions to control the mesh density. The default mesh density of 4 divisions per line is sufficient for the Surface to the right of the applied load. A graded line mesh will be created for use on the Surface to the left of the applied load.





- Select **Plane stress, Quadrilateral, Quadratic** elements.
- Enter the attribute name as **Plane Stress - Concrete**
- Click the **OK** button to add the attribute to the  Treeview.
- In the  Treeview double click the Line mesh attribute name **Divisions=6**

The Line mesh properties dialog will appear.

- Click the **Spacing** button.
- Select **Uniform transition** ratio of first to last to first element of **2** and click **OK**
- Change the attribute name to **Divisions=6 graded**
- Click the **OK** button to add the attribute to the  Treeview.

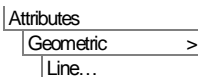
Defining the Geometric Properties



- Select **Bar/Link** from the drop down list and enter a value of **400** for the total cross sectional area of the reinforcement.
- Enter the attribute name as **Steel Area** and click the **OK** button to add the attribute to the  Treeview.

Nonlinear Analysis of a Concrete Beam

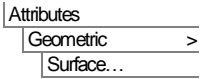

- Enter a value of **150** for the thickness. Leave the eccentricity blank.
- Enter the attribute name as **Beam Thickness** and click the **OK** button to add the attribute to the  Treeview.

Defining the Material Properties

Nonlinear steel properties will be defined for the reinforcing bar elements.

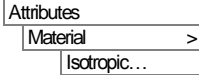

- Enter Young's modulus as **210e3** and Poisson's ratio as **0.3** and leave the mass density field blank.
- Click the **Plastic** option and enter an **Initial uniaxial yield stress** of **300**
- Select the **Hardening** option, click the **Hardening gradient** button and enter a hardening **Slope** value of **2121** with a **Plastic strain** of **1**
- Enter the attribute name as **Nonlinear Steel**
- Click the **OK** button to add the attribute to the  Treeview.

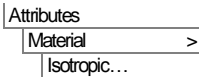

Nonlinear concrete material properties will be defined for the Surface elements representing the concrete.





- Enter a Young's modulus of **42000**, a Poisson's ratio of **0.2** and leave the mass density field blank.
- Click the **Plastic** option and from the drop-down list select the **Concrete (model 94)** entry.
- Select the **Reinforced concrete** option
- Enter a **Uniaxial compressive strength** value of **31.58**
- Enter a **Uniaxial tensile strength** value of **3.158**
- Change the **Strain at end of softening curve** to be **0.003**
- Enter the attribute name as **Nonlinear Concrete**
- Click the **OK** button to add the attribute to the  Treeview.

Assigning Attributes to the Bars

The various Line and Surface mesh, geometric and material attributes defined previously will now be assigned to the model using the groups that have been defined.

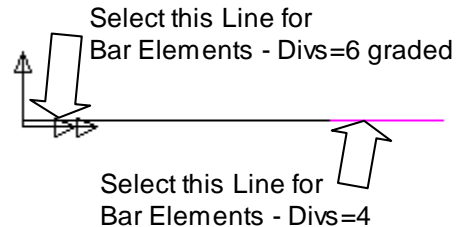

- In the  Treeview right-click the group name **Bars**. Select the **Set as Only Visible** option. The features in the group will be displayed.
- Select the left hand Line of the two Lines representing the bars.
- Drag and drop the Line mesh attribute **Bar Elements - Divs=6 graded** from the  Treeview onto the selected Line.
- Select the right hand Line of the two Lines representing the bars.
- Drag and drop the Line mesh attribute **Bar Elements - Divs=4** from the  Treeview onto the selected Line.

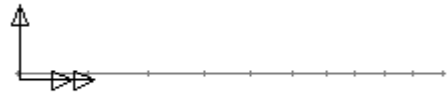

- In the  Treeview double-click on the **Mesh** entry and select **Show nodes**.



The Line mesh divisions will be seen defined with the spacing as shown.

- Select both Lines.
- Drag and drop the geometric attribute **Steel Area** from the  Treeview onto the selected features.
- Drag and drop the material attribute **Nonlinear Steel** from the  Treeview onto the selected features.





Note. The diagrams in this example show element nodes. To see these at any time you can go to the  Treeview and double-click the **Mesh** layer. On the Mesh tab select **Show nodes** and click the **Close** button.

Assigning Attributes to the Concrete

- In the  Treeview right-click the group name **Concrete**. Select the **Set as Only Visible** option.

The Lines in the Bars group will be removed from the display and the Concrete group will be displayed.

Nonlinear Analysis of a Concrete Beam

- Select the left-top and left-bottom Lines as shown.
- From the  Treeview drag and drop the Line mesh attribute **Divisions=6 graded** onto the selected features.
- Select the whole model using the **Ctrl** and **A** keys together.
- Drag and drop the Surface mesh attribute **Plane Stress - Concrete** from the 

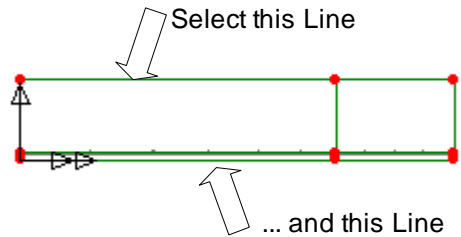

A graded mesh will be drawn on the left-hand Surface and a uniform mesh will be drawn on the right-hand Surface.

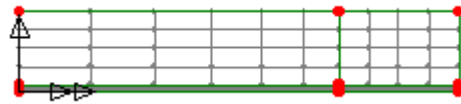

- Drag and drop the geometry attribute **Beam Thickness** from the 



Select the fleshing on/off button to turn-off the geometric visualisation. If at any time during the example you wish to visualise the geometry select this button.

- With the whole model still selected, drag and drop the material attribute **Nonlinear Concrete** from the  Treeview onto the selected features. Ensure the **Assign to surfaces** option is selected and click **OK**

The mesh on the Lines representing the cover to the centreline of the reinforcement needs to be altered. This is because they currently have a default Line mesh of 4 divisions per line when only 1 division per line is required.

- Drag boxes to select the 3 Lines as shown. (Remember to hold the **Shift** key down after the first line is selected so the other lines are added to the selection)
- Drag and drop the Line mesh attribute **Divisions=1** from the 

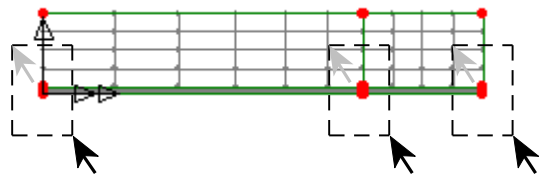

Drag 3 boxes to select these 3 Lines

The mesh will be redisplayed with the revised mesh pattern.

Making all groups visible

- From the  Treeview right-click the group heading name **beam_nl.mdl**. Select the **Set as Only Visible** option. Click **Yes** to act on sub groups as well.

All features in the model will now be displayed as shown.

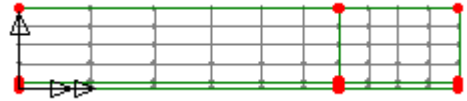

Supports

LUSAS provides the more common types of support by default. These can be seen in the  Treeview. The beam is to be simply supported in the Y direction at the left-hand end and a horizontal restraint in the X direction is required to satisfy the symmetry requirements at mid-span.

- Select the lowest Point at the left hand end of the model as shown.
- Drag and drop the support attribute **Fixed in Y** from the  Treeview onto the selected Point. Ensure the **Assign to points** and **All loadcases** options are selected and click **OK**

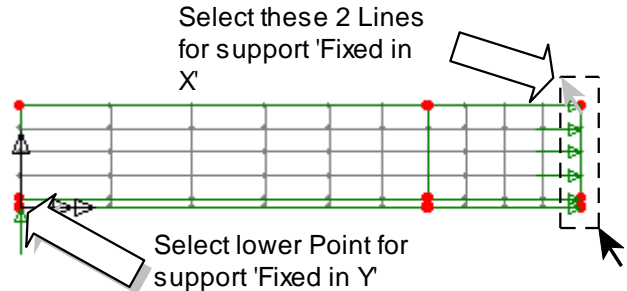

- Drag a box around the 2 Lines at the right hand end of the model as shown.
- Drag and drop the support attribute **Fixed in X** from the  Treeview onto the selected Lines. Ensure the **Assign to lines** and **All loadcases** options are selected and click **OK**

Loading

A single concentrated load is to be applied to the Point at the top of the beam. A unit load will be applied and the load factor in the nonlinear control will be used to control the magnitude of loading.

- With the **Concentrated** option selected click **Next**
- Enter a loading value of **-1** in the component **Concentrated load in Y Dir**
- Enter the attribute name as **Point Load** and click **Finish**

Attributes
Loading...

Nonlinear Analysis of a Concrete Beam

- Select the Point on the top of the beam as shown.
- Drag and drop the loading dataset **Point Load** from the Treeview onto the selected Point.
- Ensure the **Assign to points** option is set and click **OK** to assign the load to **Loadcase 1** with a factor of **1**

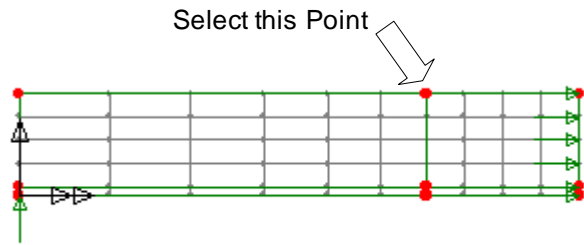

Nonlinear Control

Nonlinear analysis control properties are defined as properties of a loadcase. The nonlinear analysis is to be terminated when the beam deflection at mid span reaches a limiting value.

- Select the point shown.
- In the Treeview right-click on **Loadcase 1** and select **Nonlinear & Transient** from the **Controls** menu.

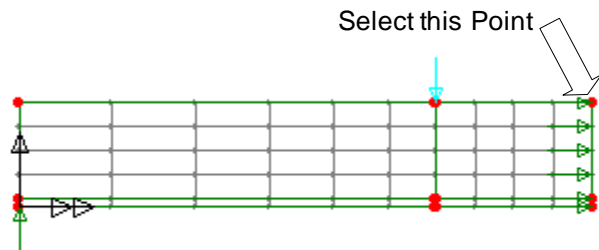

The Nonlinear & Transient dialog will appear:

- Select the **Nonlinear** option and set Incrementation to **Automatic**
- The initial load to be applied is the actual load applied to the model multiplied by the starting load factor. Set the **Starting load factor** to **5000**
- Enter the **Max change in load factor** as **2000** to restrict the second and subsequent load increment sizes to ensure sufficient points are obtained to observe the load deflection behaviour of the beam.
- Change the **Max total load factor** to **0** as the solution is to be terminated on the limiting displacement at mid span.
- Change the number of desired **Iterations per increment** to **10**



Note. If the number of iterations on the previous increment is less than the desired number the next load increment will be increased (up to the maximum change in load increment) while if the number of iterations is less than the desired number the next load increment will be reduced.

- In the Solution strategy section of the dialog, ensure the **Maximum number of iterations** is set to **25**

Nonlinear Analysis of a Concrete Beam

- Leave the **Residual force norm** as **0.1** and the **Incremental displacement norm** to **1** so convergence of the solution at each load increment will be achieved when the out of balance forces are as less than 0.1% of the reactions and the iterative change in displacements is less than 1% of the displacements for that load increment.
- Select the **Advanced** button in the Incrementation section of the dialog.

Advanced Nonlinear Incrementation Parameters

Automatic incrementation

Stiffness ratio to switch to arc-length: 0.0

Use arc length control

Arc-length calculation: Crisfield

Relative displacement arc length procedure

Guide arc length solution with current stiffness

Use root with lowest residual norm

Arc-length restart load factor: 0.0

Arc-length restart load change: 0.0

Termination criteria

Terminate on value of limiting variable

Point number: 19

Variable type: V

Value: -3.0

Step reduction

Allow step reduction

Maximum step reductions: 5

Load reduction factor: 0.5

Load increase factor: 2.0

OK Cancel Help

- Ensure that the **Stiffness ratio to switch to arc length** value is set to **0.0**
- Select the **Terminate on value of limiting variable** option.
- The selected point number (this may differ depending on how the model was created) will appear in the Point number drop down list.
- Set the **Variable type** to **V** to monitor the deflection at the selected point in the Y direction.
- Enter a value of **-3** so the analysis is terminated when the central deflection reaches this value.
- In the Step reduction section ensure the **Allow step reduction** option is selected.
- Click **OK** to return to the Nonlinear & Transient dialog.
- Click **OK** again to set the loadcase properties.

One additional setting is required for this analysis to ensure no element mechanisms are induced as the material yields.

File
Model Properties...

- Select the **Solution** tab.
- Click on the **Element Options** button and select the **Fine integration for stiffness and mass** option.
- Click the **OK** button to return the Model Properties dialog.
- Click the **OK** button to finish.

Save the model

The model is now complete and the model data is to be saved before an analysis is run using the LUSAS Solver.

File
Save



Save the model file.

Running the Analysis

With the model loaded:

File
LUSAS Datafile...



A LUSAS data file name of **beam_nl** will be automatically entered in the File name field.

- Ensure that the options **Solve now** and **Load results** are selected.
- Click the **Save** button to finish.

During the analysis 2 files will be created:

- beam_nl.out** this contains the statistics of the analysis, for example how much disk space was used, how much CPU time was used, and any errors or warning messages from LUSAS, and so on. Always check the LUSAS output file for error messages.
- beam_nl.mys** this is the LUSAS results database which will be used for results processing.



Note. Warnings will be written to the text output window during this analysis. Warnings are not to be confused with errors which normally stop an analysis from being run. The warnings are written to advise you of modelling-related issues that are found during the analysis and of the steps LUSAS has taken (if any) to allow the analysis to continue.

If the analysis is successful...

The LUSAS results file will be displayed in the Treeview.

If the analysis fails...

If the analysis fails, information relating to the nature of the error encountered can be written to an output file in addition to the text output window. Select **No** to not view the output file. Any errors listed in the text output window should be corrected in LUSAS Modeller before saving the model and re-running the analysis.

Rebuilding a Model

If it proves impossible for you to correct the errors reported a file is provided to enable you to re-create the model from scratch and run an analysis successfully.



- beam_nl_modelling.vbs** carries out the modelling of the example.



 Start a new model file. If an existing model is open Modeller will prompt for unsaved data to be saved before opening the new file.

- Enter the file name as **beam_nl**

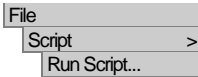

To recreate the model, select the file **beam_nl_modelling.vbs** located in the **\<LUSAS Installation Folder>\Examples\Modeller** directory.



 Rerun the analysis to generate the results.

Viewing the Results

If the analysis was run from within LUSAS Modeller the results will be loaded on top of the current model and the loadcase results for load increment 1 are set to be active by default.

Changing the Active Results Loadcase

- In the  Treeview right-click on the last load increment **Increment 9 Load Factor = 16972.6** and select the **Set Active** option.

Deformed Shape

- In the  Treeview turn off the **Geometry**, **Attributes** and **Mesh** layers by right clicking on each entry and selecting the **On/Off** option.

- With no features selected, click the right-hand mouse button in a blank part of the graphics window and select the **Deformed mesh** option to add the deformed mesh layer to the  Treeview.
- Click **OK** to accept the default properties and view the deformed mesh for the final load increment.

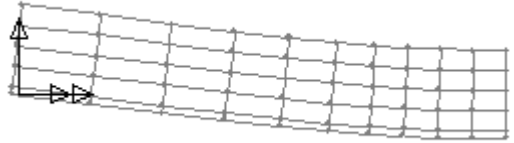

Creating a Load versus Displacement Graph

A graph of displacement at mid-span is to be plotted against the applied load. To do this a node on the line of symmetry is selected:

- With the **Deformed mesh** layer visible, select the top node on the axis of symmetry as shown.

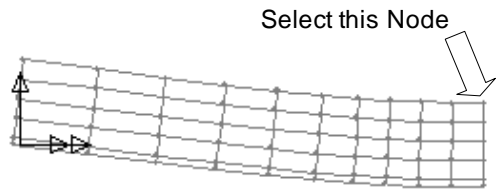

Using the Graph Wizard

The graph wizard provides a step-by-step means of selecting which results are to be plotted on the X and Y axes of the graph. The X axis is always defined first.

Utilities
Graph Wizard...

- Ensure the **Time history** option is selected and click the **Next** button.
- Ensure the **Nodal** results is selected and click **Next**
- Select entity **Displacement** for component resultant displacement **RSLT**
- The node number selected earlier will be displayed in the drop-down list.
- Click the **Next** button.

The Y axis results to be graphed are now defined.

- Select the **Named** option and click **Next**
- Select **Total Load Factor** from the drop down list.
- Click the **Next** button.

Nonlinear Analysis of a Concrete Beam

- Leave all title information blank and click the **Finish** button to display the load deformation graph.



Note. Graphs can be modified using the right hand mouse button in the graph window and selecting the **Edit Graph Properties** option.



Close the graph window.



Use the maximise button to increase the size of the graphics window.

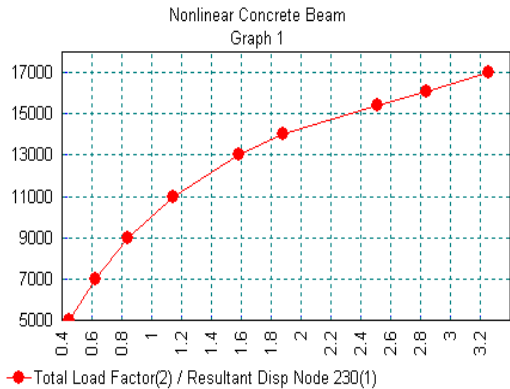

Maximum Principal Stress Contour Plots

- With no features selected, click the right-hand mouse button in a blank part of the graphics window and select the **Contours** option to add the contours layer to the Treeview.

The properties dialog will be displayed.

- Select entity **Stress - Plane Stress** for component of stress in the x direction, **SX**

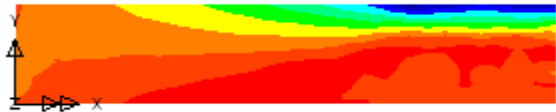

- Click the **OK** button to display contours of stresses for the final load increment.
- In the Treeview turn off the **Deformed mesh** layer.

Viewing Crack Patterns

- With no features selected, click the right-hand mouse button in a blank part of the graphics window and select the **Values** option to add the values layer to the Treeview.

The properties dialog will be displayed.

- Select **Stress - Plane Stress** contour results of type **Crack/crush**
- Select **Values Display** tab and press the **Failure details...** button to change the pen colour that is used to plot negative yield to **Black**.

- Select the **Scale** button and specify a **magnitude** of **2**.
- Click the **OK** button to display the cracking pattern for final load increment superimposed onto the stress contours.

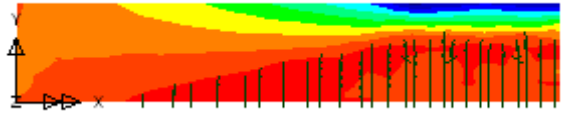

Animating the Results

As an alternative to viewing results individually for each loadcase, the change of stress due to the increasing load increments can be animated instead. To ensure consistent contour values throughout the animation the interval of the range of contours is to be specified.

- In the  Treeview double-click on the **Contours** layer.

The contour properties will be displayed.

- Select the **Contour Range** tab and click the **Interval** option and set the contour interval as **1**
- Click the **Maximum** button and set the maximum value as **3**
- Click the **Minimum** button and set the minimum value as **-16**
- Click the **Set as global range** and **Use global range** options.
- Click the **OK** button to redisplay the stress contours using the new contour range.

Using the Animation Wizard

- Select the **Load History** option and click the **Next** button.
- Select **beam_nl.mys** from the drop-down list.

Utilities

Animation Wizard...

- Select the **All loadcases** option and select the **Finish** button to create the animation sequence.



Note. The buttons at the bottom of the window may be used to slow-down, speed-up, pause, step through frame by frame, or stop the animation.

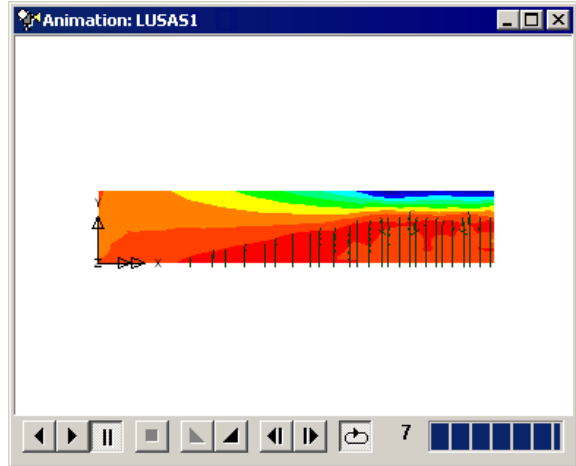



Saving Animations

Animations may be saved for replay in Windows animation players.

- Ensure the animation window is the active window.
- Browse to your projects folder and enter **beam_nl** for the animation file name. An **.avi** file extension is automatically appended to the file name. Click **Save**
- Animations can be compressed to save disk space. A number of compression formats are available depending on what is installed on the system. **Microsoft Video 1** has been found to provide reliable results. Click **OK**

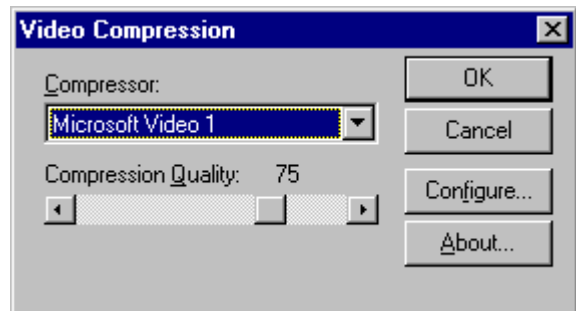
File
Save As AVI...



 Close the animation window, choosing not to save changes.

 Enlarge the model window to a full size view.

Creating a slice section of results

In this example a graph is to be plotted of the variation in stress through the specified section of the beam. The X axis values of distance are defined by the section slice. The Y axis results are specified from the graph wizard dialog.

Utilities

Graph Through 2D

- Ensure the **Snap to grid** option is selected and a grid size of **100** is specified.
- Click the **OK** button.



Note. The snap to grid dialog will only appear if the model is viewed in the XY plane. If necessary, return the model to the default starting view by clicking

Z: N/A on the status bar at the bottom of the graphics window.

- Using the screen ruler as a guide, click and drag the cursor as shown to define the location of a section slice through the beam at a distance of **1600** from the left-hand end.

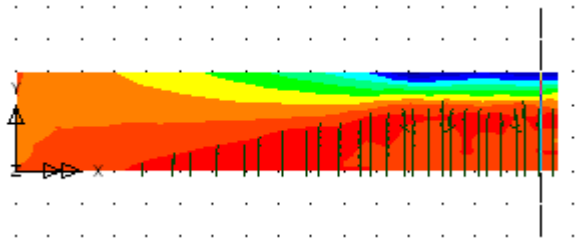

- Select **Stress - Plane Stress** results for Stress **SX** and click the **Next** button.
- Leave all title information blank.
- Click the **Finish** button to create the graph of stress through the section of beam.

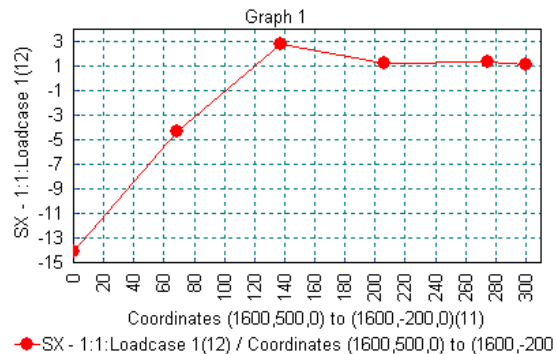

Adding Additional Results to a Graph

- Re-select the window containing the results contours. The cursor will still be in section slice mode.

Window

1 LUSAS View
beam_nl.mdl Window 1

Nonlinear Analysis of a Concrete Beam

- Using the screen rulers as a guide, click and drag the cursor as shown to define the location of a section slice through the beam at a distance of **1000** from the left-hand end.

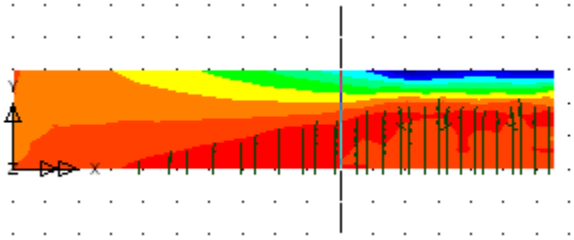

- Select **Stress - Plane Stress** results for Stress **SX** and click the **Next** button.
- Click the **Add to existing graph** option.
- Click the **Finish** button to add the results for the second slice to the existing graph.

Re-select the existing graph to see the overlaid data.

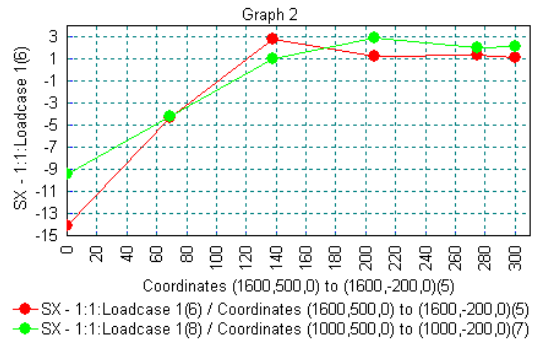

This completes the example.

Window
2 Graph1:Graph 1

Contact Analysis of a Lug

For software product(s):	All (except LT versions) for the first stage of the example Any Plus version for the second stage of the example.
With product option(s):	Nonlinear (for the second part of the example)
Note: Stage 2 of the example exceeds the limits of the LUSAS Teaching and Training Version.	

Description : Linear Material

A large lug is supported at its left-hand edge and subjected to a prescribed pressure load around the inside of the hole, modelling a loaded pin.

The lug is 0.546 m thick and made of steel with a Young's modulus of $210\text{E}9 \text{ N/m}^2$, a Poisson's ratio of 0.3 and a mass density of 7800kg/m^3 .

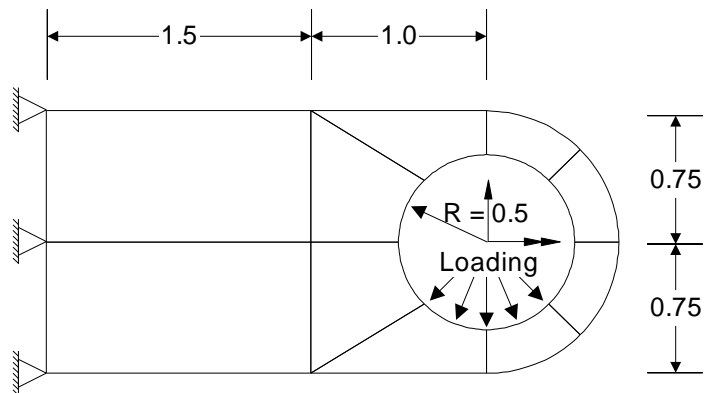

This is a two stage example. A linear static analysis is carried out initially and the material properties and loading are then modified to investigate the response of the lug using a nonlinear analysis.

Units used are N, m, kg, s, C throughout.

Objectives

The output required from the linear analysis consists of:

- Deformation Plot** A plot of the undeformed and deformed mesh.
- Contour Plot** A Von Mises stress plot.
- Principal Stress Vectors** A plot of principal stress vectors.
- Fatigue Damage** A plot of the fatigue damage when the component is subjected to a prescribed loading sequence.
- Cycles to Failure** A contour plot of the number of cycles to failure for the area around the hole.

Keywords

2D, Default Assignments, Linear, Slideline, Nonlinear, Contact, Fatigue, Damage, Cycles to Failure, Stress Contours, Displacement Results, Animation, Graph Plotting.

Associated Files



- lug_linear_modelling.vbs** carries out the modelling for the linear analysis.
- lug_nonlinear_modelling.vbs** carries out the modelling for the nonlinear contact analysis.

Stage 1. Linear Material Analysis

An initial linear investigation is performed to verify the model. An assessment of potential damage and a calculation of the cycles to failure is performed.

Stage 2. Nonlinear Material Analysis

Material properties on the linear model are then modified to investigate the response of the lug using a nonlinear analysis. The pressure loading is removed and an additional pin of 0.9m diameter is defined. Slidelines are defined on the surfaces that will come into contact and the pin is then subjected to a prescribed concentrated loading and moved into contact with the lug.

Stage 1 : Modelling : Linear Material

Running LUSAS Modeller

For details of how to run LUSAS Modeller see the heading *Running LUSAS Modeller* in the Examples Manual Introduction.



Note. This example is written assuming a new LUSAS Modeller session has been started. If continuing from an existing Modeller session select the menu command **File>New** to start a new model file. Modeller will prompt for any unsaved data and display the New Model dialog.

Creating a new model

- Enter the file name as **lug_linear**
- Use the **Default** working folder.
- Enter the title as **Fixing Lug (Linear analysis)**
- Set the units to **N,m,kg,s,C**
- Select a **Structural** user interface.
- Select the startup template **Standard**
- Specify the vertical axis in the **Y** direction.
- Click the **OK** button.



Note. Save the model regularly as the example progresses. Use the Undo button to correct any mistakes made since the last save was done.

Default Attribute Assignments

The material properties of the lug, its element type and thickness are uniform over the model. Default attribute assignments can therefore be used, meaning that any material, mesh or geometry attribute defined will be automatically assigned to any features that are subsequently generated.

Default Element Selection

The lug is a relatively thin structure and all deformations take place in the plane of the structure therefore plane stress continuum elements will be used.

- Select **Plane stress, Quadrilateral, Quadratic** elements. Ensure the **Regular mesh** option is selected with **Automatic** mesh divisions so that LUSAS uses the

Attributes	
Mesh	>
Surface...	

Contact Analysis of a Lug

default number of mesh divisions on each line. Leaving the attribute name blank causes LUSAS to create a suitable default attribute name. Click **OK**

Modeller will add the **Surface Mesh 1** attribute to the  Treeview.



- To make this attribute the default for all subsequent geometry, click the right-hand mouse button on the mesh attribute **Surface Mesh 1** in the  Treeview and select the **Set Default** option.

The selected attribute will be highlighted to signify that it has been set as the default for all subsequent features.

Default Geometric Properties

- Enter the thickness as **0.546**. No eccentricity needs be entered.
- Enter the attribute name as **Lug Thickness 0.546** and click **OK**.
- To make this attribute the default for all subsequent geometry click the right-hand mouse button on the geometry attribute name in the  Treeview and select the **Set Default** option.

Default Material Properties

- Select material **Mild Steel** of type **Ungraded** from the drop-down lists and click **OK** to add the material attribute to the  Treeview.
- To make the mild steel material attribute the default for all subsequent geometry click the right-hand mouse button on the **Iso1 (Mild Steel Ungraded)** material attribute name in the  Treeview and select the **Set Default** option.

Defining the Geometry

Use will be made of the symmetry of the lug by defining the top half and then mirroring it to form the whole structure. In this problem the centre of the hole will be taken as the origin (0,0,0).

 Define a Surface by specifying the coordinates of its vertices using the following values **(-2.5, 0)**, **(-1, 0)**, **(-1, 0.75)** and **(-2.5, 0.75)**.

 Select the fleshing on/off button to turn-off geometric property visualisation.

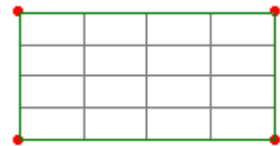



Note. Whenever a Surface is created the corresponding Surface mesh will be displayed.

For clarity the diagrams accompanying this example will not generally show the mesh. At any time the mesh can be turned on or off by right-clicking on the Mesh entry in the  Treeview and selecting the On/Off menu item.

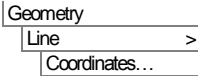

 Define a Line by specifying the coordinates of either end as **(0.5, 0)** and **(0.75, 0)**.

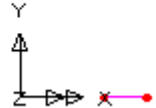

The resulting features should be as shown.



Note. LUSAS will automatically generate any necessary lower order features when higher order features are defined.

New Surfaces will be created by sweeping the Line just drawn through a positive (anti-clockwise) angle about the centre of the hole.

- Select the new Line.

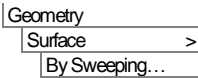

 **Rotate** the Line through an angle of **45** degrees about the Z-axis and an origin of (0,0,0) to sweep through a **Minor arc** to create the surface.

Copy this Surface to form next Surface

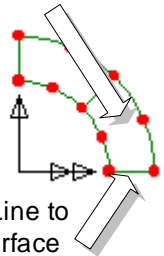



Select this Line to form first Surface

- Enter the attribute name as **Rotate 45 Degrees** so that it can be re-used.
- Click on the **Save** button to save the attribute information and click the **OK** button to finish.

LUSAS will create a new Surface from the selected Line. This will now be copied to create the adjoining surface.

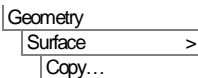
- Select the Surface just created



 On the Copy dialog, select the **Rotate 45 degrees** attribute from the drop-down list to use the values defined.

Contact Analysis of a Lug

- Click the **OK** button to create the new

The arc forming the Surface of the hole is to be extended.

- First, select the Point shown.

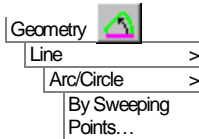

Select the **Rotate 45 degrees**

attribute from the drop-down list to use the values defined.

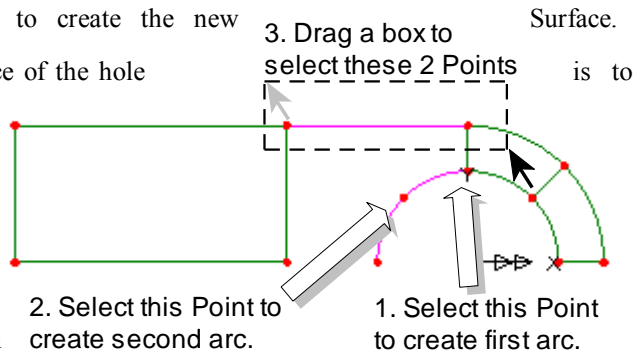

- Click the **OK** button to create the new arc.
- Secondly, select the Point at the end of the new arc and repeat the previous process to draw a second arc.
- Thirdly, drag a box around the two unconnected Points at the top of the model.



Select the new Line button to create the connecting Line.

Two new Surfaces will now be formed by joining existing Lines.

- Select the first two Lines required in the order shown remembering to use the **Shift** key to add to the initial selection.

- Use the joining function, to create a surface between the specified lines.

- Repeat for the remaining two Lines as shown.

The top half of the lug is now complete.

Mirroring the Lug

The bottom half of the lug is to be formed by mirroring the top half.

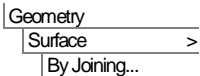
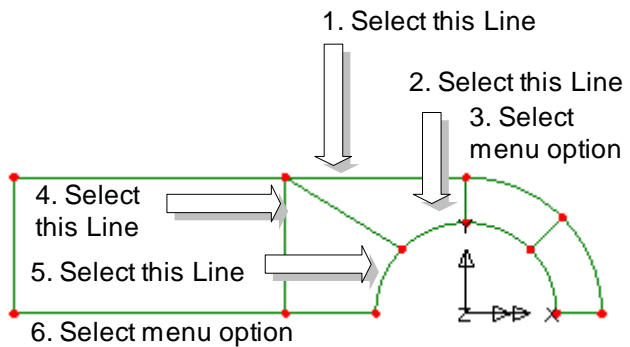

- Select 2 Points on the centreline.

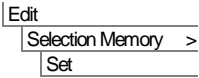

The points are stored in memory.

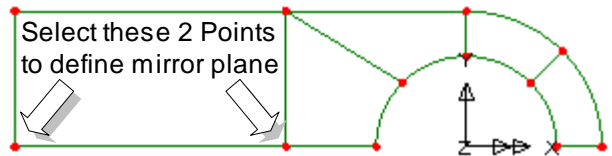

- Drag a box around the whole of the top half of the lug or use the **Ctrl + A** keys together to select the whole model.

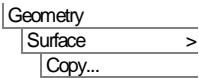

 Select the **Mirror – from Point 1 and Point 2** from the drop down list and click the **Use** button to use the mirror transformation defined. Click the **OK** button to finish. The surfaces will be copied and mirrored.

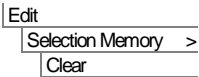

The points are cleared from selection memory.



Note. As a consequence of mirroring the Surfaces, the orientation of the Surfaces in the top half of the model will be opposite to the orientation of the Surfaces in the bottom half of the model. The orientation of the Surfaces must therefore be checked.

Aligning Surface axes

To ensure the loading directions are consistent the element axes should be aligned. The element axes follow the direction of the surface they are generated from. These may vary depending upon how your surfaces were created.

- In the  Treeview right click on **Geometry** and select **Properties**
- On the properties dialog select the **Surface axes** button and click **OK** to display the surface axes.

The axes of all surfaces can be aligned to axes of the first surface in the selection using the cycle relative facility.

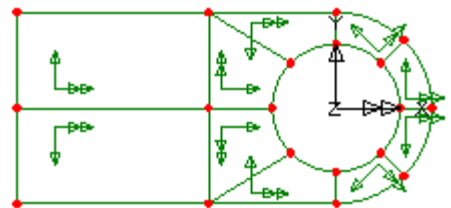

- Select the top left-hand surface.
- Hold the **Shift** key and box-select the whole model to add the remaining surfaces to the selection.

Contact Analysis of a Lug

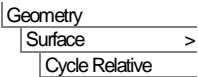

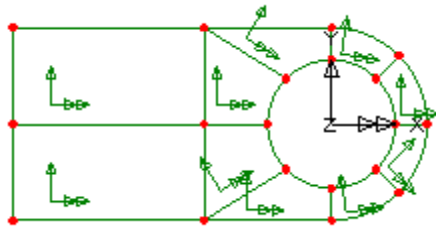

The axes of all surfaces will be aligned to the axes of the first element selected.

- In the  Treeview right click on **Geometry** and select **Properties**
- On the properties dialog deselect the **Surface axes** button and click **OK** to remove the surface axes from the display.



Supports

LUSAS provides the more common types of support by default. These can be seen in the  Treeview.

- Drag a box around the 2 vertical Lines on the left of the model.
- Drag the support attribute **Fixed in XY** from the  Treeview and drop onto the selected Lines in the graphics window.

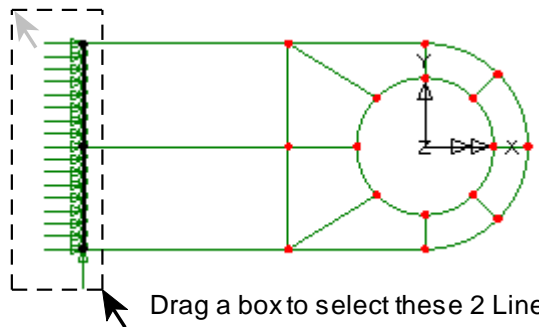

Drag a box to select these 2 Lines

- Choose options to **Assign to lines** for **All loadcases** and click **OK** to finish assigning the support attribute.

The supports will be visualised as arrows at the supported nodes in the directions of the restraints.

Loading



In this linear analysis, pin loading is to be approximated by defining a face load of a value equivalent to the full load that will be applied during the nonlinear analysis. The face load will be assigned to the 2 Lines defining the lower side of the hole.

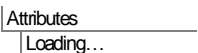

Note. Face loads are applied in local element directions, hence a load in the Y direction will act in a radial direction.

- Select the **Face** option and click **Next**
- Input a load value of **10e6** in the Component **y** direction.



- Enter the attribute name as **Face Load** and click **Finish** to add the attribute to the  Treeview.
- Select the 2 arcs forming the lower side of the hole, then drag and drop the **Face Load** attribute from the  Treeview onto the selected features.
- Ensure that **Loadcase 1** and a **Load factor** of **1** are used and that the loading is assigned to Lines only.
- If not already displayed, turn on the display of the mesh.

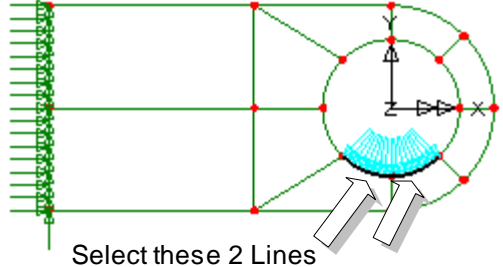

Saving the model

File
Save



Save the model file.

Running the Analysis : Linear Material

With the model loaded:

File
LUSAS Datafile...



A LUSAS data file name of **lug_linear** will be automatically entered in the File name field.

- Ensure that the options **Solve now** and **Load results** are selected.
- Click the **Save** button to finish.

A LUSAS Datafile will be created from the model information. The LUSAS Solver uses this datafile to perform the analysis.

If the analysis is successful...

The LUSAS results file will be added to  Treeview.

In addition, 2 files will be created in the directory where the model file resides:



- ❑ **lug_linear.out** this output file contains details of model data, assigned attributes and selected statistics of the analysis.

- ❑ **lug_linear.mys** this is the LUSAS results file which is loaded automatically into the  Treeview to allow results processing to take place.

If the analysis fails...

If the analysis fails, information relating to the nature of the error encountered can be written to an output file in addition to the text output window. Any errors listed in the text output window should be corrected in LUSAS Modeller before saving the model and re-running the analysis.

Rebuilding a Model

If it proves impossible for you to correct the errors reported a file is provided to enable you to re-create the model from scratch and run an analysis successfully.



- ❑ **lug_linear_modelling.vbs** carries out the modelling of the example.



Start a new model file. If an existing model is open Modeller will prompt for unsaved data to be saved before opening the new file.

- Enter the file name as **lug_linear**

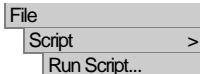

To recreate the model, select the file **lug_linear_modelling.vbs** located in the **\<LUSAS Installation Folder>\Examples\Modeller** directory.



Rerun the analysis to generate the results.

Viewing the Results : Linear Material

If the analysis was run from within LUSAS Modeller the results will be loaded on top of the current model and the loadcase results for Loadcase 1 are set to be active by default.

For clarity, the lug geometry will be removed from the display to leave only the undeformed mesh displayed.

- If present, turn off the display of the **Geometry** and **Attributes** layers from the  Treeview.

Using Page Layout Mode

The model was created using a Working Mode view which allows a model of any size to be created. Results could be viewed using this mode of operation, but, in order to allow additional information to be added without obscuring the model, Page Layout Mode can be used instead.

View
Page Layout Mode

The Graphics window will resize to show the mesh layer on an A4 size piece of paper.

File
Page Setup...



- Ensure that the **Landscape** option is selected, ensure that page margins of **60,10,10,10** are set for left, right, top and bottom margins respectively and click **OK**

This page layout view can also be saved for subsequent re-use with other models.

Window
Save View...

- Enter the view name as **Landscape Page Layout** and click **OK**

Deformed Mesh Plot

- Ensure the **Mesh, Geometry and Attributes** layers are turned Off in the  Treeview.
- With no features selected click the right-hand mouse button in a blank part of the Graphics window and select the **Deformed mesh** option to add the deformed mesh layer to the  Treeview.
- Click on the **OK** button to accept the default properties and display the deformed mesh.

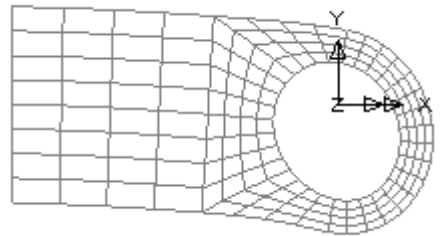

Von Mises Stress Contours

- With no features selected click the right-hand mouse button in a blank part of the graphics window and select the **Contours** option to add the contours layer to the  Treeview.



The contour layer properties will be displayed.

- Select **Stress - Plane Stress** contour results of equivalent stresses **SE**

Contact Analysis of a Lug

- Click the **OK** button to display the contours and annotated contour summary.



Note. The order of the layer names in the  Treeview determines the order in which the layers will be displayed in the graphics window. To ensure a particular layer is displayed after another layer, click on the layer name to be moved in the  Treeview and drag the layer name onto the layer name after which it is to be displayed. The display in the graphics window will be updated accordingly.

- Move the **Deformed mesh** layer to follow the **Contours** layer in the  Treeview as described in the previous note.

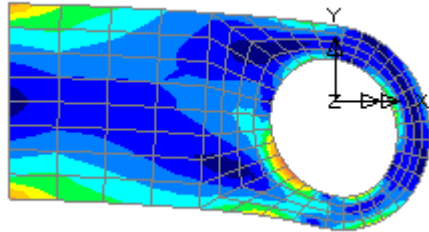

Marking Peak Values



- With no features selected click the right-hand mouse button in a blank part of the Graphics window and select the **Values** option to add the values layer to the  Treeview.

The values properties will be displayed.

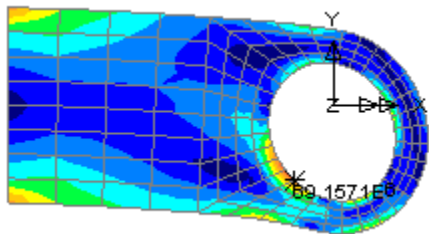
- Select **Stress - Plane Stress** contour results of Equivalent stresses **SE**
- Select the **Values Display** tab and set **Maxima** values to display the top 1% of results on the Deformed shape.
- Click the **OK** button to redisplay the contours with the peak value marked.



Principal Stress Vectors

- Turn off the **Contours** and **Values** layers in the  Treeview.
- With no features selected, click the right-hand mouse button in a blank part of the Graphics window and select the **Vectors** option to add the vectors layer to the  Treeview.

The vector layer properties will be displayed.

- Select **Stress - Plane Stress** vector results.
- Click the **OK** button to display vectors with tension vectors displayed in red and compression vectors displayed in blue.
- Turn off the **Vectors** layer in the  Treeview.

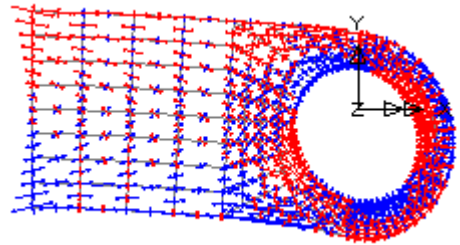



Defining a Fatigue Spectrum

Utilities

Fatigue...

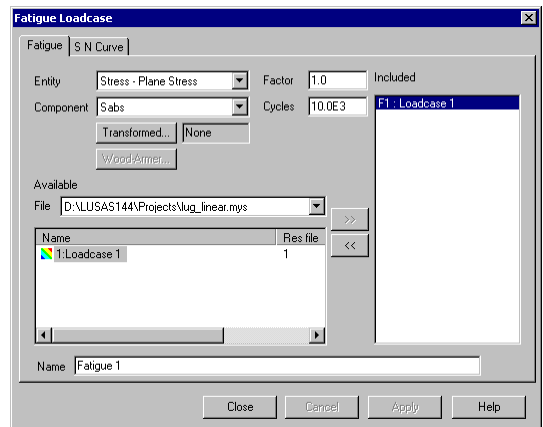
- Ensure **lug_linear.mys** is selected from the drop-down list.
- Select **Loadcase 1**
- Click the  'Add to' button to include Loadcase 1 in the fatigue load spectra calculation.
- Click on **Loadcase 1** in the Included panel of the dialog and enter the number of **Cycles** as **10000**





- Leave the name as **Fatigue 1** and select **Sabs** from the component drop-down list.
- Select the **S N Curve** tab and enter the values as shown in the adjacent table.
- Click the **OK** button to finish.
- In the  Treeview right-click on the loadcase **Fatigue 1** and select the **Set Active** option.

Log Stress/Strain	Log Cycle
4.7323	15
9.7323	0

Contouring Damage

Contouring damage must be done on an undeformed mesh view.

- Turn off the **Deformed mesh** layer in the  Treeview.
- Turn on the **Mesh** layer in the  Treeview.

Contact Analysis of a Lug

- Turn on the **Contours** layer in the  Treeview.

The contour plot properties will be displayed.

- Select **Stress - Plane Stress** and ensure contour results of **Damage** are selected.
- Select the **Contour Display** tab and ensure the **Contour key** option is selected.

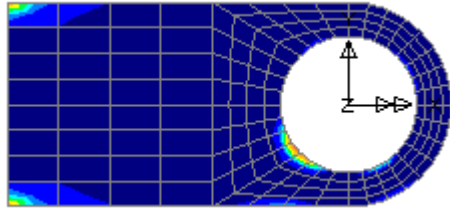

- Click the **OK** button to display contours of damage and a contour summary.
- Move the **Mesh** layer to follow the **Contours** layer in the  Treeview so the mesh is visible on top of the contour display.

Contouring Cycles to Failure

Modeller can calculate the number of repeats of a given loading sequence to failure. An extra fatigue spectrum will be created containing only a single loading cycle.

- Ensure **lug_linear.mys** is selected from the drop-down list.
- Select **Loadcase 1**
- Click the  'Add to' button to include Loadcase 1 in the fatigue load spectra calculation.
- Leave the name as **Fatigue 2** and select **Sabs** from the component drop-down list.
- Select the **S N Curve** tab and enter the values as shown in the table.
- Click the **OK** button to finish.

Log Stress/ Strain	Log Cycle
4.7323	15
9.7323	0

In the  Treeview right-click on the loadcase **Fatigue 2** and select the **Set Active** option.

- In the  Treeview double-click on the **Contours** layer.

The contour plot properties will be displayed.

- Select **Stress - Plane Stress** contour results of **Damage**
- Click the **Close** button to display the contours and a summary of cycles to failure.

Utilities
Fatigue...

- Double-click on the **Contours** layer again.
- Select entity **Stress - Plane Stress** contour results of component **Log-Life**
- Click the **OK** button to display contours of log life.



Note. As an alternative to having to enter S N Curve data again for this second loadcase, double-clicking on loadcase Fatigue 1 and changing the loadcase name to Fatigue 2 and setting the number of Cycles to 1 would achieve the same result.

Changing the levels

The contours of log-life will be easier to understand if the contour levels are adjusted so that they are plotted in unit (1.0) increments, representing 10 to the power of 0 cycles to failure.

- In the  Treeview, double-click on the **Contours** layer name and select the **Contour Range** tab.
- Set the Contour range to show a contour **Interval** of **1**. Ensure the **Value to pass through** is set to **0**
- Click the **OK** button to display contours of Log Life and a contour summary using the increments specified.

A maximum value of 14.78 should be obtained for the log-life.

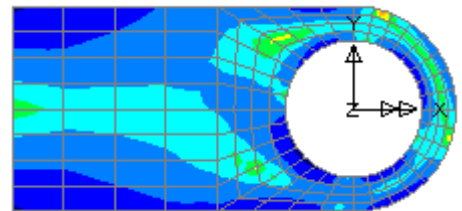
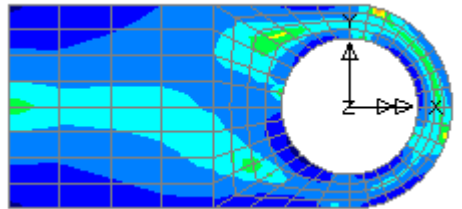

This completes the linear analysis section of the example.



Note. Saving the model file now would save the fatigue loadcases also.

Nonlinear Contact

For software product(s):	Any Plus version.
With product option(s):	Nonlinear.
Note: This stage exceeds the limits of the LUSAS Teaching and Training Version.	

Description : Nonlinear Material

This part of the example extends the previously defined lug model used for the linear analysis.

The pressure loading is removed and an additional pin of 0.9m diameter is defined. Slidelines are defined on the surfaces that will come into contact and the pin is then subjected to a prescribed concentrated loading and moved into contact with the lug.

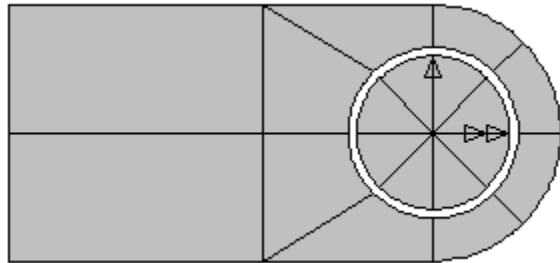

A schematic of the lug and pin geometry is shown.

The units of the analysis are N, m, kg, s, C throughout.

Objectives

The output required from the analysis is as follows:

- Equivalent Stress Contours** A plot of the stress in the lug only.
- Graph of Displacement against Applied Load** A graph of the resultant displacement at a selected node.

Stage 2 : Modelling : Nonlinear Material

If the linear analysis was successful:

 If the previous linear analysis was performed successfully open the model file **lug_linear.mdl** saved after completing the first part of this example and select **No** to not load a results file of the same name on top of this model.

- Enter the model file name as **lug_nonlinear** and click the **Save** button.

File _____
Open... _____

File _____
Save As... _____

Rebuilding model from a supplied file

If the linear analysis was not successful a file is provided to enable you to re-create the model for use in this part of the example.

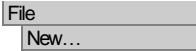

Start a new model file. If an existing model is open Modeller will prompt for unsaved data to be saved before opening the new file.

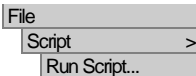

- Enter the file name as **lug_nonlinear**



To recreate the model, select the file **lug_linear_modelling.vbs** located in the **\<LUSAS Installation Folder>\Examples\Modeller** directory.

Changing the model description



- Change the model title to **Fixing Lug - Nonlinear Contact Analysis** and click **OK**
- If present, turn off the **Contours** and **Annotation** layers in the  Treeview.
- Turn on the **Geometry** layer.
- In the  Treeview ensure **Loadcase 1** is set active.

Defining the Lug

For clarity the diagrams accompanying this example will not generally show the mesh.

- Drag a box around the whole of the model (or use the **Ctrl + A** keys) to select the whole model.



Select the group button to create a group.

- Enter the name **Lug** and click **OK** to finish creating the group and add it to the  Treeview.

Defining the Pin

- Select the Line on the lug shown. Take care to not include any other features.



Select the **Scale** option and enter a scale factor of **0.9**

- Click the **OK** button to create the arc.



Enter coordinates of **(0, 0)** to define a point at the origin and click **OK**

- Select the Line just created and holding the **Shift** key down, also select the point at the origin.



A new Surface will be created. The other surfaces of the pin will be created shortly.

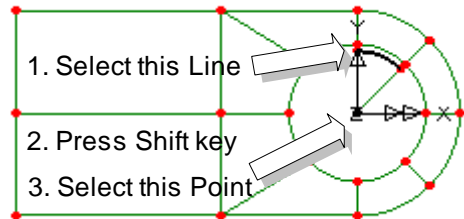
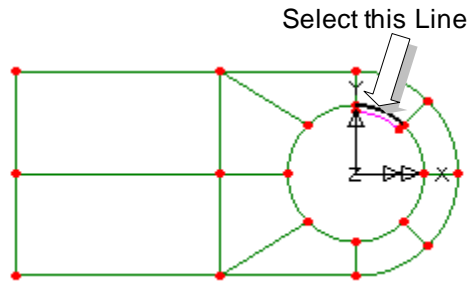

Modifying the Line mesh divisions

The total number of mesh divisions on the Pin is to be reduced and modified.

- Turn on the **Mesh** layer.

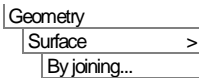
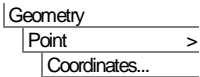
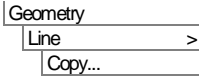

- Select the arc on the initial segment of the pin.
- Drag and drop the Line mesh attribute **Divisions=2** from the  Treeview onto the selected Line.
- With the Element description set as **None**, enter the number of divisions as **2**
- Click the **Spacing** button, select a **Uniform transition** ratio of last to first element of **0.333** and click **OK** to return to the mesh dialog.
- Enter the attribute name as **Divisions=2(3:1)** and click **OK**

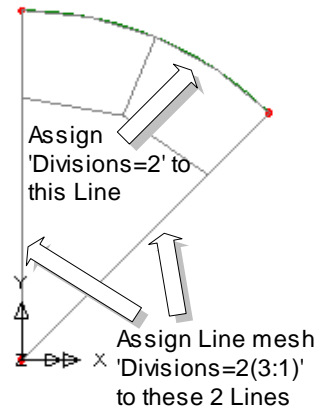
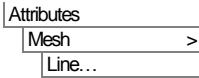

LUSAS will add the attribute name to the  Treeview.

- Select the 2 straight Lines on the first surface of the Pin.
- Drag and drop the Line mesh attribute **Divisions=2(3:1)** from the  Treeview onto the selected features.



Note. The last/first element spacing ratio depends upon the direction of the Line on which it is assigned. If the mesh is finer at the centre of the Pin than at the edge then reverse the line(s) by first selecting with the mouse and using the menu command **Geometry>Line>Reverse**

The remainder of the Pin is to be generated by copying the initial segment of the Pin.

- Select the Surface defining one-eighth of the Pin.

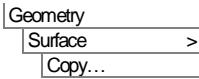

 From the drop-down list, select the attribute **Rotate by 45 degrees**

- Set the number of copies to **7**
- Click the **OK** button to create the new Surfaces forming the entire pin.

Using Groups

To allow easy selection of the features defining the pin, the group named **Lug** is to be hidden.

- In the  Treeview right-click on the group name **Lug** and select the **Invisible** option to leave just the Surfaces representing the pin displayed.

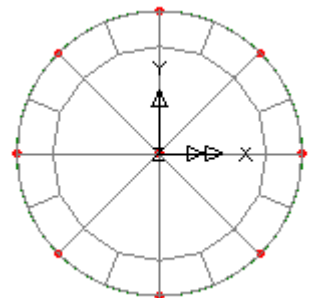

Contact Analysis of a Lug

- Drag a box around the features defining the pin (or use the **Ctrl + A** keys).



Select the group button to create a group.

- Enter the name **Pin** and click **OK** to finish creating the group and add it to the  Treeview.

Geometric properties of the pin

- Enter the thickness as **10** and the attribute name as **Pin Thickness 10**. Click **OK**
- Box-select the Pin in the Graphics Area and drag and drop this geometric dataset from the  Treeview onto the selected features.

Redisplay the lug

- In the  Treeview right-click on the group name **Lug** and select the **Visible** option to re-display the lug.

Modifying the mesh

Contact problems using slidelines require linear rather than quadratic elements to be used.

- In the  Treeview double-click on the **Surface Mesh 1** attribute name.
- Change the interpolation order to **Linear** and click **OK** to overwrite the previous mesh details.
- If not already displayed, display the mesh layer.

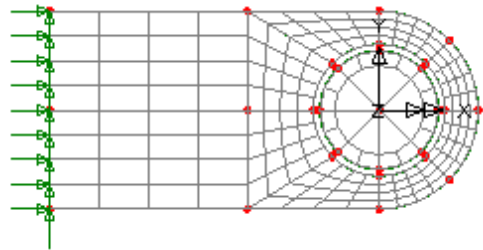

The mesh arrangement should be as shown.

Slidelines

Slidelines define the contacting Surfaces of the model. They are used in pairs (a master and a slave) and define opposing contacting Surfaces. They are assigned to Lines for 2D analyses and to Surfaces for 3D analyses. In this analysis, the master and slave slides are assigned to selected internal Lines of the Lug and selected external Lines of the Pin.

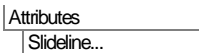
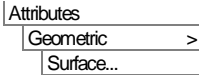

- Ensure that the **Close Contact** parameter is set to **0.1** and leave the remaining values as their default settings.

- Enter the attribute name as **Lug_Pin** and click **OK**

- Select the 4 internal lower arcs of the Lug.

- Drag and drop the slideline attribute **Lug_Pin** from the Treeview onto the selected features, setting this slideline to be the **Master**. Leave the orientation as **Default** and click **OK**

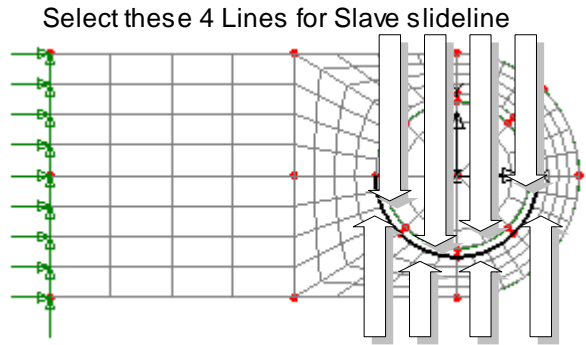

Select these 4 Lines for Master slideline

- Select the 4 lower arcs of the Pin.

- Drag and drop the slideline attribute **Lug_Pin** from the Treeview onto the selected features, setting this slideline to be the **Slave** and click **OK**

- To visualise the slidelines assigned to the model click the right-hand mouse button on the slideline attribute name in the Treeview and select **Visualise Master Assignments** and **Visualise Slave Assignments**

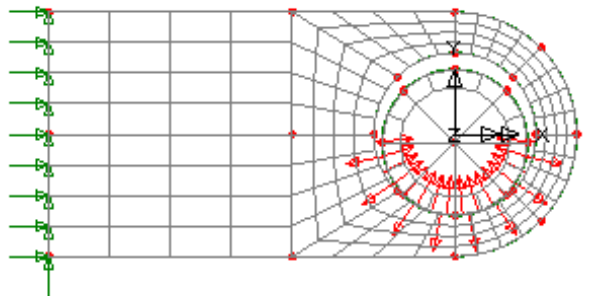

- After visualising, de-select the visualisation of both sets of slidelines.

Supports and Loads

The loading from the first part of this example is to be removed and will be replaced by a concentrated load. The supports will remain unaltered.

- In the Treeview click the right-hand mouse button on the loading attribute **Face load**. Select the **Deassign > From all** option.

Contact Analysis of a Lug

Attributes
Loading...

- With the **Concentrated** option selected click **Next**
- Input a load in the **Y** direction of **-2e8**.
- Enter the load attribute name as **Concentrated Load** and click the **Finish** button.
- Select the Point at the centre of the Pin.
- Drag and drop the loading attribute **Concentrated Load** from the  Treeview onto the selected point, ensuring that it is applied as **Loadcase 1**

Preventing features from merging together

Now that the modelling is complete the pin can be moved into contact with the lug. This could be done by entering a known dimension, or, as shown in this example, by selecting the Points to be brought into contact. To prevent the features in the pin merging with those on the lug when the pin is moved into contact the points in the pin are set as unmergable.

- Select all the features in the pin by selecting **Pin** in the  Treeview and picking the **Select Members** option.

This ensures the points in the pin are not merged with those in the lug.

Geometry
Point >
Make Unmergable

Moving the Pin to touch the Lug

- Select the lowest Point on the Pin. Make a note of the Point number selected in the text output pane.
- Holding the **Shift** key down, select the Point immediately beneath it on the hole of the Lug. Make a note of the Point number shown in the Selected box of the status bar.
- Click the right-hand mouse button and select the **Selection Memory>Set** option.
- In the  Treeview right-click on the group name **Pin** and select the **Select members** option to highlight all features representing the pin. Click **OK** to deselect the previously selected Points.

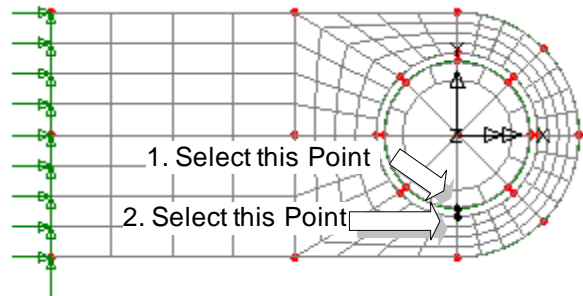

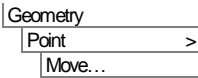

 Select the **Translation – from Point 45 to point 30** transformation (or the one that relates to your selected points) from the drop down menu and click the **Use** button to use the distance between the Points stored in memory as the move distance. Click the **OK** button to finish.

The pin will be moved to rest against the lug at the starting point of the analysis.

Nonlinear Analysis Control

Nonlinear analysis control properties are defined as properties of a load case.

- In the  Treeview right-click on **Loadcase 1** and select the **Nonlinear and Transient** option from the **Controls** menu.

The Nonlinear & Transient dialog will appear:

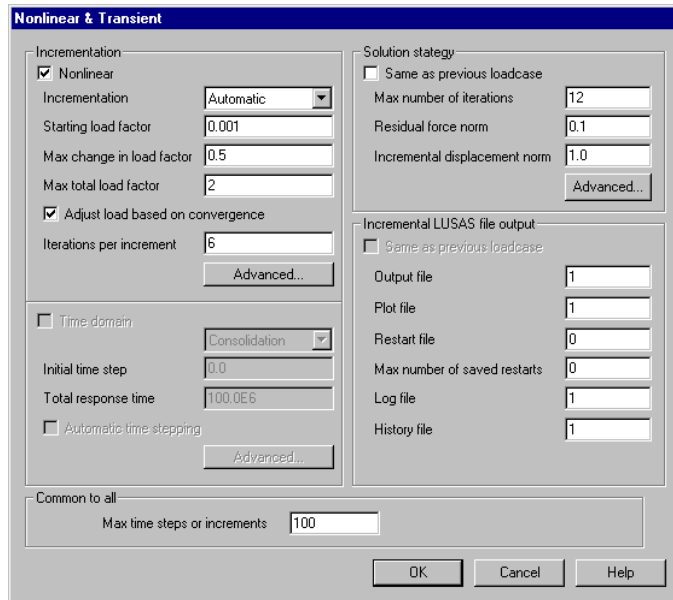

- Select **Nonlinear** incrementation with **Automatic** control.
- Enter the **Starting load factor** as **0.001**
- Enter the **Max change in load factor** as **0.5**
- Enter the **Max total load factor** as **2**
- Ensure that **Adjust load based on convergence** is selected.
- Enter the number of **Iterations per increment** as **6**

- Enter the **Maximum time steps or increments** as **100**
- Click the **OK** button to finish.



Note. A nonlinear contact analysis performs best when a small amount of load (0.001 of the load in this example) is applied to the model initially. Thereafter, once the results for a load increment have been obtained the load factor for the next increment is automatically adjusted by LUSAS based upon the number of iterations taken for the previous load increment to converge. After a number of such iterations the loading will be progressively applied to the model until the total load factor is reached.

Saving the model

The model is now complete and the model data is to be saved before an analysis is run using the LUSAS Solver.

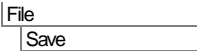

To save the model.

Running the Analysis : Nonlinear Material

With the model loaded:



A LUSAS data file name of **lug_nonlinear** will be automatically entered in the File name field.

- Ensure that the options **Solve now** and **Load results** are selected.
- Click the **Save** button to finish.

During the analysis 2 files will be created:

- lug_nonlinear.out** this contains the statistics of the analysis, for example how much disk space was used, how much CPU time was used, and any errors or warning messages from LUSAS, and so on. Always check the LUSAS output file for error messages.
- lug_nonlinear.mys** this is the LUSAS results database which will be used for results processing.

If the analysis is successful...

The LUSAS results file will be displayed in the  Treeview.

If the analysis fails...

In the event of the analysis failing due to errors in the model that you cannot correct, a file is provided to re-create all modelling features and attributes to allow the analysis to be run successfully.



- lug_nonlinear_modelling.vbs** carries out the modelling of the example.

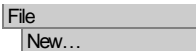

Start a new model file. If an existing model is open Modeller will prompt for unsaved data to be saved before opening the new file.

- Enter the file name as **lug_nonlinear**

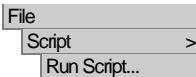

To recreate the model, select the file **lug_nonlinear_modelling.vbs** located in the **\<LUSAS Installation Folder>\Examples\Modeller** directory.



Rerun the analysis to generate the results.

Viewing the Results : Nonlinear Material

If the analysis was run from within LUSAS Modeller the results will be loaded on top of the current model and the load case results for load increment 1 are set to be active by default.



Making the Pin invisible



Note. When a results file is loaded on top of a corresponding model file groups of features can be made visible or invisible. This is of particular use when results are to be displayed only on selected parts of the model. In this example, results are only to be viewed on the Lug.

- In the  Treeview right-click on the group name **Lug** and select the **Set as Only Visible** option.

Deformed Mesh Plot

- Turn off the **Geometry**, **Mesh** and **Attributes** layers in the  Treeview.
- Turn on the **Deformed mesh** layer in the  Treeview.

The deformed mesh plot will be displayed.

Equivalent Stress Contour Plots

- Turn on the **Contours** layer in the  Treeview.

The contour properties will be displayed.

- Select **Stress - Plane Stress** contour results of Equivalent stresses **SE**
- Click the **OK** button to display contours and a contour summary for the first load increment.
- Change the layer display order to display the **Deformed mesh** on top of the **Contours** by selecting **Deformed Mesh** in the  Treeview with the right-hand mouse button and selecting the **Move Down** option.

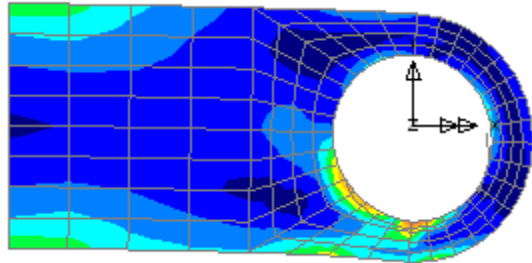

Changing the Active Results Loadcase

- In the  Treeview right-click on the last increment for load factor 2 and select the **Set Active** option.

The contour plot for the final increment will be displayed.



Note. Results for the other increments may be viewed simply by changing the active load case.

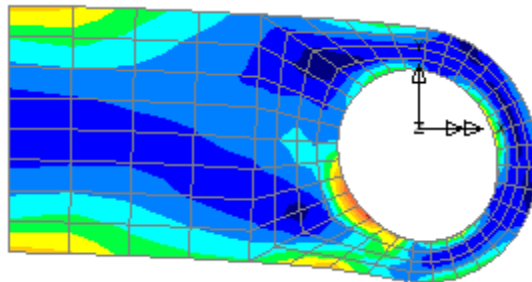

Creating Animations

As an alternative to viewing results individually for each load case, the change of stress due to the increasing load increments can be animated instead. To ensure consistent contour values throughout the animation the range of contours is to be specified.

For the final load increment the contour key shows a maximum stress in the order of $6.8E9$. To create contours of $5E8$ intervals the contour interval needs to be set.

- In the  Treeview double-click on **Contours**. The contour layer properties will be displayed.
- Select the **Contour Range** tab and click the **Interval** button. Set the contour interval as **5E8**. Click the **Set as global range** button and ensure that the **Use global range** button is also selected.
- Click the **OK** button to finish.



Note. When animating nonlinear loadcases it is important that the deformed mesh is plotted using a factor of 1 and not using a fixed screen size otherwise the deformed mesh for each load increment would be drawn the same. With this in mind:

- In the  Treeview double-click on the **Deformed mesh** layer, select the **Specify Factor** option, enter a factor to **1** and click **OK**
- Select the **Load history** option and click the **Next** button.

Utilities

Animation Wizard...

- Select **lug_nonlinear.mys** from the drop-down menu. The list of available load cases for selection will appear. Select the **All loadcases** button and the **Finish** button to create an animation for all loadcases and display the animation in a new window.

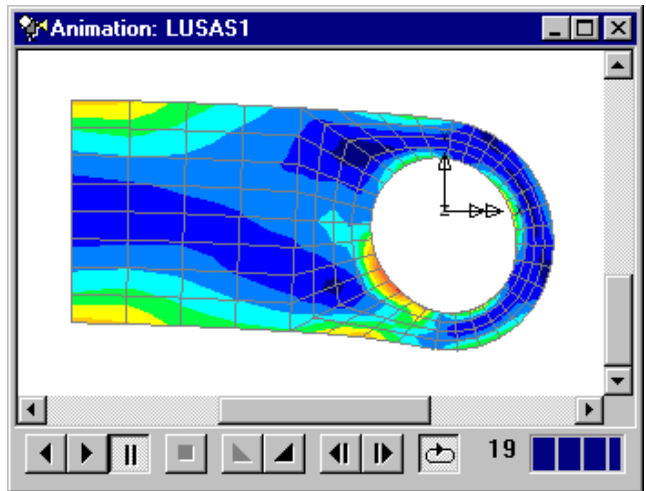

Note. The buttons at the bottom of the window may be used to slow-down, speed-up, pause, step through frame by frame, or stop the animation.

Saving Animations

Animations may be saved for replay in other standard windows animation players.

- Ensure the animation window is the active window.
- Enter **lug_nonlinear** for the animation file name. An **.avi** file extension is automatically appended to the file name when the file is saved.

File

Save As AVI...

Contact Analysis of a Lug

- Animations can be compressed to save disk space. A number of compression formats are available depending on what is installed on the system. **Microsoft Video 1** has been found to provide reliable results. Click **OK**

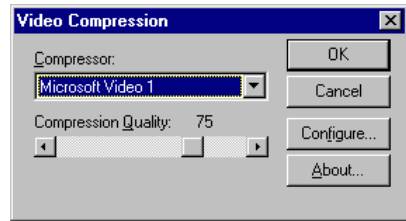

- Delete the animation window and maximise the graphics window.
- Turn off the display of the Annotation layer in the  Treeview.

Creating Graphs

Any set of results may be graphed against any other set of results. For example, a graph of resultant displacement for the node at the bottom of the hole of the lug is to be plotted against the load increment.

- Select the node defining the bottom of the hole in the lug.

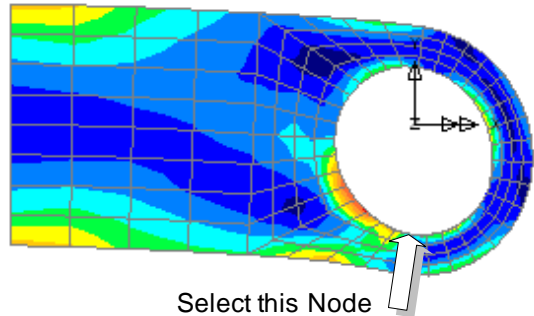

The graph wizard provides a step-by-step means of selecting which results are to be plotted on the X and Y axes of the graph. The X axis is always defined first.

- Ensure the **Time history** option is selected and click the **Next** button.
- Ensure the **Nodal** results button is selected and click the **Next** button.
- Select **Displacement** results for resultant displacement **RSLT**. The node number of the previously selected node will be shown in the Specify node pull-down. Click the **Next** button.

The X axis results have been selected. The Y axis results to be graphed are now defined.

- Select **Named** results and click the **Next** button.
- Select **Total Load Factor** data. Click the **Next** button.

Title information for the graph can be added at this stage.

Utilities
Graph Wizard...

- Leave all title information blank.
- Click the **Finish** button

A graph is created in a new window with the values used shown in an adjacent table.

 To see the graph at the best resolution enlarge the window to a full size view.





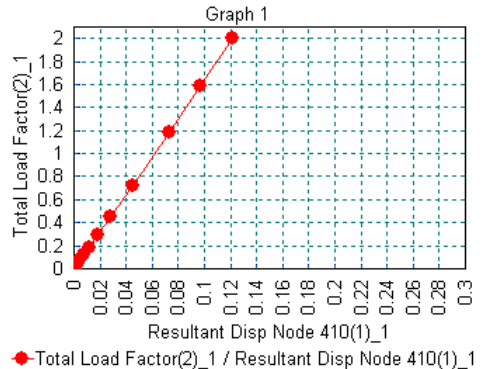

Note. The graph shows a linear displacement history for the node. This is because no geometric nonlinearity has been allowed for in the analysis.



- Close the graph using the  in the top right-hand corner of the graph window.

Slideline Results

Results can be presented on the contact surfaces as vectors or values, or as a graph on any specified load increment.

- Turn off the **Contours** and **Deformed mesh** layers in the  Treeview.
- Turn on the **Mesh layer** in the  Treeview.
- In the  Treeview select the slideline results group on which the results are to be displayed by right-clicking on the group **Lug_Pin (master)** and selecting the **Set as Only Visible** option. Click **Yes** to act on sub groups.
- In the  Treeview ensure that the last load increment showing **Load Factor = 2.00000** is active.
- With no features selected, click the right-hand mouse button in a blank part of the graphics window and select the **Values** entry.
- In the properties box, select the Entity **Slideline Results** and the Type **ContPress** to look at results of Contact Pressure.
- Select the **Values Display** tab and de-select **Symbols**, ensure both **Maxima** and **Minima** are selected, set the range to **100 %** and change the number of significant figures to **3**. Click the **OK** button.

Contact Analysis of a Lug

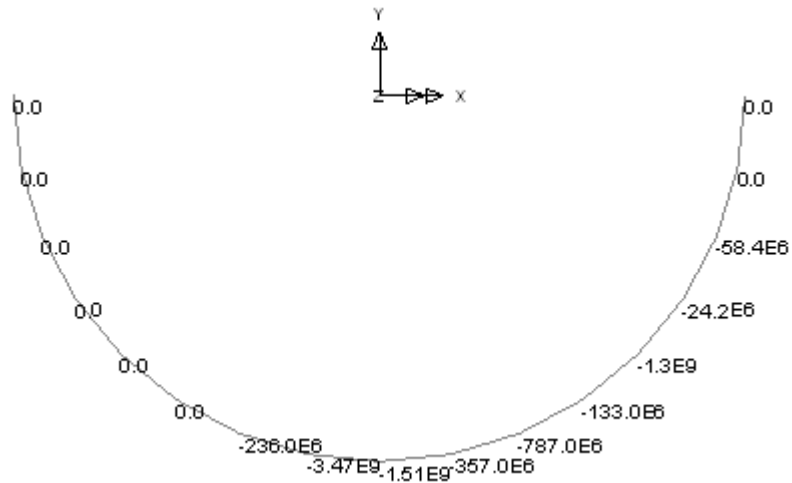

To plot a graph of the contact pressure distribution around the contact surface:

Utilities
Graph Wizard...

- Choose the **Slidelines (assigned to lines)** option and click **Next**
- Select the Component **ContPress**
- To plot the results against angle rather than length select the **Calculate distance as angle** option.
- Click **Next** followed by **Finish**

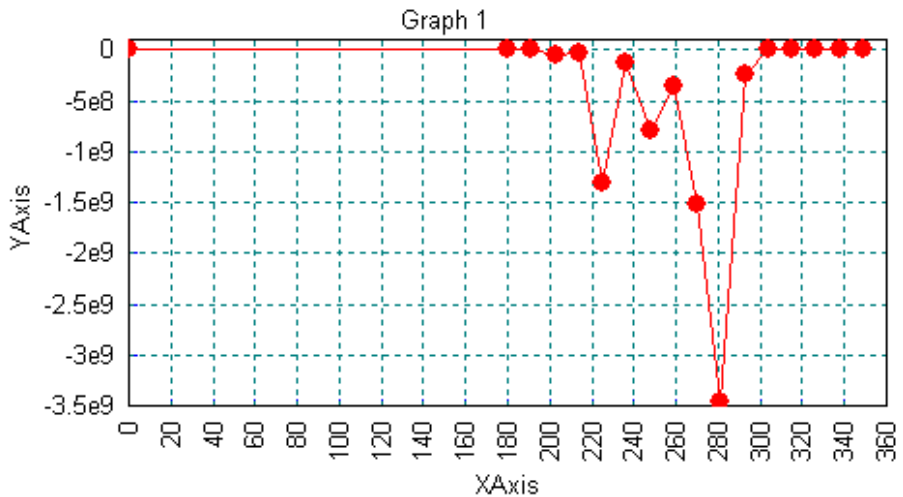

● Stress ContPress(4)_1 / Angle(3)_1



Note. The graph properties and titles may be modified using the right-hand mouse button in the graph window if required.

This completes the nonlinear analysis part of the example.

Linear Buckling Analysis of a Flat Plate

For software product(s):	All (except LT versions)
With product option(s):	None.

Description

This example determines the critical buckling load for a 2m x 0.5m rectangular panel of 1mm thickness subject to in-plane compressive loading.

Material properties for the panel are: Young's modulus $70E9 \text{ N/m}^2$, Poisson's ratio 0.3.

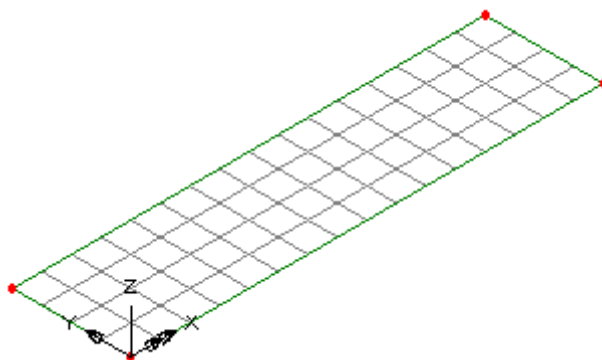

The panel is meshed using 64 Semiloof shell elements and is simply supported on all sides. An in-plane compressive load of a total of 24N is applied to one of the short edges, parallel to the long sides.

Units used are N, m, kg, s, C throughout.

Keywords

2D, Plate, Linear Buckling, Eigenvalue Buckling, Deformed Mesh, Printing

Associated Files



- **plate_modelling.vbs** carries out the modelling of the example.

Modelling

Running LUSAS Modeller

For details of how to run LUSAS Modeller see the heading *Running LUSAS Modeller* in the Examples Manual Introduction.



Note. This example is written assuming a new LUSAS Modeller session has been started. If continuing from an existing Modeller session select the menu command **File>New** to start a new model file. Modeller will prompt for any unsaved data and display the New Model dialog.

Creating a new model

- Enter the file name as **plate**
- Use the **Default** working folder.
- Enter the title as **Buckling of a flat plate**
- Set the units to **N,m,kg,s,C**
- Ensure the **Structural** user interface is selected.
- Select the model template **Standard**
- Select the **Vertical Z axis** option.
- Click the **OK** button.



Note. Save the model regularly as the example progresses. Use the Undo button to correct any mistakes made since the last save was done.

Feature Geometry

Geometry
Surface >
Coordinates...



Enter coordinates of $(0, 0)$, $(2, 0)$, $(2, 0.5)$ and $(0, 0.5)$ to define a Surface.

- Click the **OK** button.



Meshing

Attributes
Mesh >
Surface...



- Select **Thin shell, Quadrilateral**, elements with **Quadratic** interpolation.
- Enter the attribute name as **Thin Shell**.
- Click the **OK** button.

LUSAS will add the mesh dataset to the  Treeview.

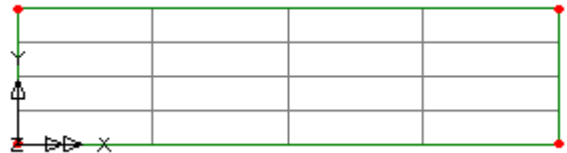
- Select the Surface of the plate.
- Drag and drop the Surface mesh attribute **Thin Shell** from the  Treeview onto the selected feature.



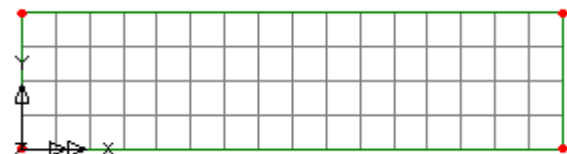

Note. If the number of divisions is not specified on the mesh dialog the default number of 4 divisions per Line will be used. In this example 4 divisions per Line is sufficient for the ends of the plate but 16 divisions are required on each of the sides.

- In the  Treeview double-click on the Line mesh **Divisions=8**
- On the Line Mesh dialog change the number of line divisions to **16**, change the Attribute name to **Divisions=16** and click the **OK** button.
- Select the two long sides of the plate and drag and drop the Line mesh attribute **Divisions=16** from the  Treeview onto the selected features.



Geometric Properties



- Specify a thickness of **0.001**.
 - Enter the attribute name as **Plate Thickness**
- (The eccentricity can be left blank, as it is not used in this analysis).
- Click the **OK** button to add the attribute to the  Treeview.
 - With the Surface selected, drag and drop the geometry attribute **Plate Thickness** from the  Treeview onto the selected feature.

Assigned geometric attributes are visualised by default.



Select the fleshing on/off button to turn-off geometric property visualisation.



Material Properties

- Specify the Young's modulus as **70E9**
 - Enter Poisson's ratio as **0.3**
- (Mass density can be left unspecified for Eigenvalue buckling analyses).
- Enter the attribute name as **Plate Material**
 - Click the **OK** button to add the attribute to the  Treeview.
 - With the Surface selected, drag and drop the material attribute **Plate Material** from the  Treeview onto the selected surface.

Supports

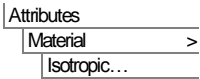
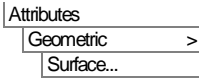
LUSAS provides the more common types of support by default. These can be seen in the  Treeview. Four support datasets are to be assigned to selected features of the model.



- Select the top line, hold the **Shift** key, and select the left and bottom Lines as shown.
- Drag and drop the **Fixed in Z** support attribute from the  Treeview onto the selected Lines.
- Ensure that the supports are assigned to Lines for **All loadcases** and click the **OK** button.
- Similarly for each of the other features shown above drag and drop the relevant support attributes from the  Treeview to assign the required supports.

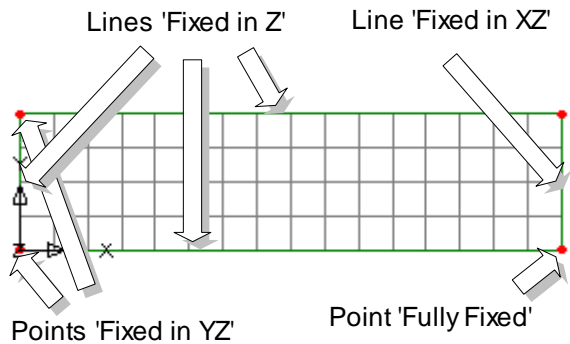

Use the Isometric button to rotate the model to this view.

- Check the position and type of supports on the model match those above.

Loading

A global distributed load is to be applied to the left-hand end of the plate.

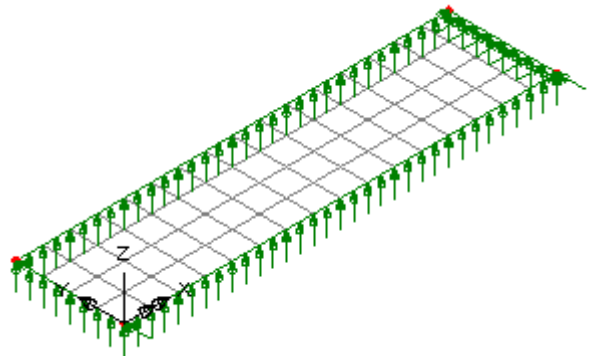

Linear Buckling Analysis of a Flat Plate

Attributes
Loading...

- Select the **Global Distributed** option and click **Next**
- Enter a **Total** load of **24** in the **X** direction.
- Enter the attribute name as **Distributed Load**.
- Click the **Finish** button.
- Select the left hand edge of the plate and drag and drop the loading dataset **Distributed Load** from the  Treeview onto the selected Line.
- Click **OK** to assign the load to **Loadcase 1** with a factor of **1**

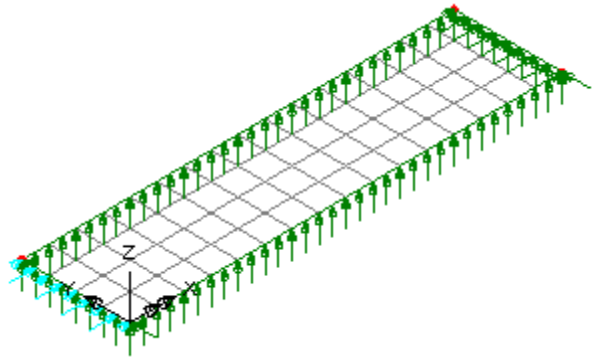

Eigenvalue Analysis Control

Eigenvalue analysis control is defined as a loadcase property.

- In the  Treeview right-click on **Loadcase 1** and select **Eigenvalue** from the **Controls** menu.

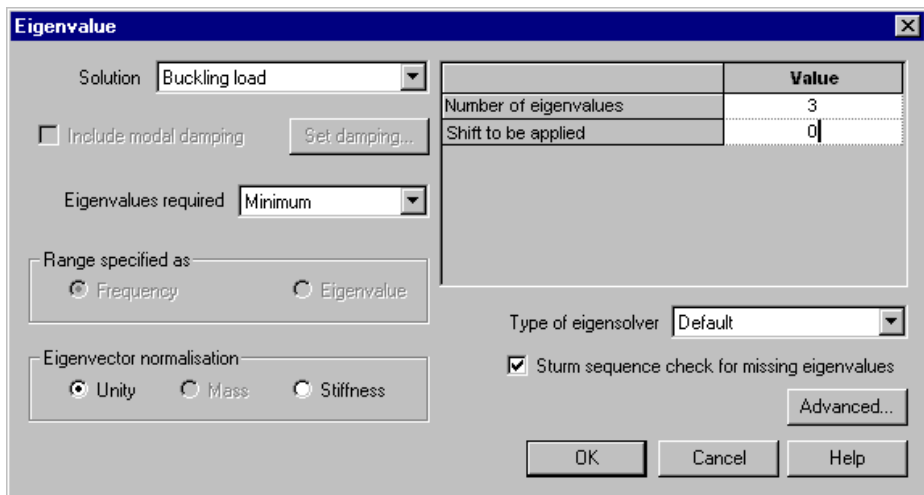

- Select a **Buckling Load** solution for the **Minimum** number of eigenvalues.
- Enter the **Number of eigenvalues** required as **3**
- Enter the **Shift to be applied** as **0**
- Click the **OK** button to select the **Default** eigensolver.

Saving the model

File
Save



Save the model file.

Running the Analysis

File
LUSAS Datafile..



A LUSAS data file name of **plate** will be automatically entered in the File name field.

- Ensure that the options **Solve now** and **Load results** are selected.
- Click the **Save** button to solve the problem.

A LUSAS Datafile will be created from the model information. The LUSAS Solver uses this datafile to perform the analysis.

If the analysis is successful...

Eigenvalue results files will be seen in the  Treeview.

In addition, 2 files will be created in the directory where the model file resides:



- plate.out** this output file contains details of model data, assigned attributes and selected statistics of the analysis.
- plate.mys** this is the LUSAS results file which is loaded automatically into the Treeview to allow results processing to take place.

If the analysis fails...

If the analysis fails, information relating to the nature of the error encountered can be written to an output file in addition to the text output window. Select **No** to not view the output file. Any errors listed in the text output window should be corrected in LUSAS Modeller before saving the model and re-running the analysis.

Rebuilding a Model

If it proves impossible for you to correct the errors reported a command file is provided to enable you to re-create the model from scratch and run an analysis successfully.



- ❑ **plate_modelling.vbs** carries out the modelling of the example.

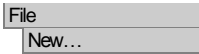

Start a new model file. If an existing model is open Modeller will prompt for unsaved data to be saved before opening the new file.

- Enter the file name as **plate**

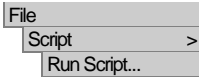

• To recreate the model, select the file **plate_modelling.vbs** located in the **\<LUSAS Installation Folder>\Examples\Modeller** directory.

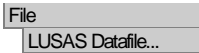

Rerun the analysis to generate the results.

Viewing the Results

If the analysis was run from within LUSAS Modeller the results will be loaded on top of the current model and the loadcase results for each eigenvalue can be seen in the Treeview.

- Turn off the **Mesh**, **Geometry** and **Attributes** layers in the Treeview.

Deformed Mesh Plot

- With no features selected, click the right-hand mouse button in a blank part of the Graphics window and select the **Deformed mesh** option to add the deformed mesh layer to the Treeview with a magnitude of **6**. Click the **OK** button to display the first eigenmode shape.

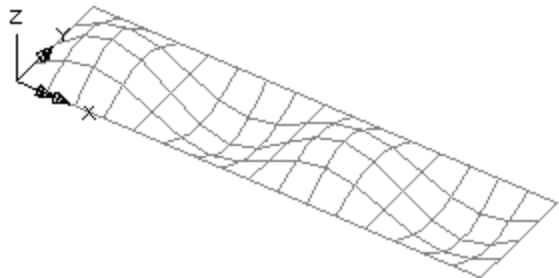



Use the Dynamic Rotation button to ensure that the model is rotated to a similar view to that shown.



Return to normal cursor mode

Changing the Results Loadcase

To view the second eigenmode:

- In the Treeview right-click on **Eigenvalue 2** and select the **Set Active** option.

The second eigenmode shape will be displayed.

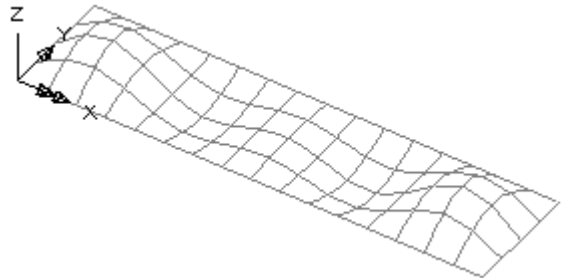

The third eigenmode can be viewed in a similar manner.



Note. Mode shapes may be the opposite to those shown.

Printing the Buckling Load Factors

- In an eigenvalue buckling analysis, the load factors are equivalent to the eigenvalues. Load factors are the values by which the applied load is factored to cause buckling in the respective modes. Eigenvalue results for the whole model can be displayed in the text window.
- Select the entity **None** and ensure that results type **Eigenvalues** is selected and click the **Finish** button.

The Eigenvalue results will be printed to the text window with the Load factors being given in the eigenvalue results column

```
Results File = C:\Lusas140\Projects\plate.mys ID= 0
  MODE   EIGENVALUE   LOAD FACTOR   ERROR NORM
    1     19.8891      19.8891      0.211729E-09
    2     21.1542      21.1542      0.200042E-08
    3     21.3180      21.3180      0.529051E-07
```

Note that error norms may vary from those shown.

Utilities

Print results wizard...

Calculating the Critical Buckling Load

The applied load (24N) must be multiplied by the first load factor (19.0779) to give the value of loading which causes buckling in the first mode shape. The initial buckling load is therefore $24 \times 19.0779 = 457.87$ N.



Note. An applied load of unity could be used in an eigenvalue analysis - in which case the eigenvalues produced would also represent the critical loads at which the structure would buckle. However, to prevent potential convergence problems with the analysis it is more usual to apply actual in-service loading and multiply the applied load by the eigenvalue to give the critical buckling load for each eigenvalue.

This completes the example.

Elasto-Plastic Analysis of a V- Notch

For software product(s):	All (except LT versions) for the first stage of the example Any Plus version for the second stage of the example.
With product option(s):	Nonlinear (for the second stage of the examples)
Note: Stages 3 and 4 of the example exceed the limits of the LUSAS Teaching and Training Version.	

Description

A 5mm thick V-shaped, notched specimen is to be subjected to two load types; a pressure load distributed along the inner edge of its opening and a loading caused by pushing a bolt into the notch of the specimen.

After an initial linear analysis with the specimen subjected to the pressure load, nonlinear material properties are defined and a nonlinear analysis is carried out using the same pressure loading.

An additional linear and nonlinear analysis is done to investigate the insertion of a bolt into the notch of the specimen with slidelines being used to model the contact behaviour between the two components. Because of symmetry only half of the V-notch need be modelled.

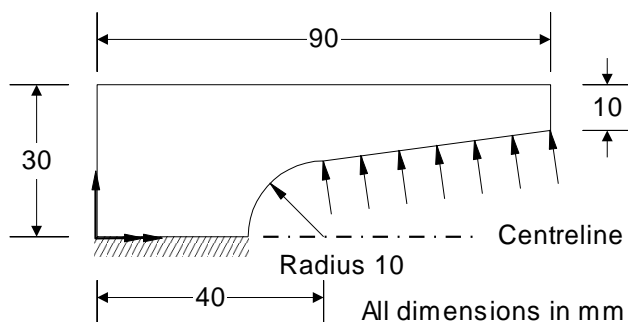

Units are N, mm, t, s, C throughout.

Objectives

- Initial Yield** Investigate the load which causes initial yielding.
- Spread of Yield** Under continued loading investigate the progression of plastic deformation under pressure loading.
- Ultimate Capacity (Pressure)** Investigate the ultimate capacity of the specimen under pressure loading.
- Transfer of Force from Bolt** Investigate the transfer of forces from the loading bolt from a preliminary linear contact and subsequent nonlinear contact analysis.

Keywords

Plane Stress, Contact, Geometrically Nonlinear (GNL), Materially Nonlinear (MNL), Contour Plot, Elasto-Plastic, Yield, Yield Symbol, Plastic Strain, Animation

Associated Files



- vnotch_linear_modelling.vbs** carries out the modelling for the linear notch analysis.
- vnotch_nonlinear_modelling.vbs** carries out the modelling of the nonlinear material model.
- vnotch_linear_contact_modelling.vbs** carries out the modelling of the specimen using a linear analysis and a geometrically nonlinear model.
- vnotch_nonlinear_contact_modelling.vbs** carries out the modelling of the notch and bolt with nonlinear material properties.

Discussion

The response of this component is dominated by materially nonlinear effects. After an initially elastic response, the material undergoes elastic-plastic yielding. In a simple von Mises model the tensile and compressive stress regions are considered to cause identical plasticity. The post-yield response is governed by the hardening slope. A zero slope denotes elastic-perfectly plastic behaviour.

Stage 1. Linear Material Analysis

An initial linear investigation is performed to verify the model and to find the maximum stress induced by a unit intensity load. This information is used to design the incrementation strategy for the initial coarse nonlinear analysis.

Stage 2. Nonlinear Material Analysis

The material nonlinearity is specified in LUSAS by the addition of plastic material properties and a hardening curve.

The nonlinear strategy is designed such that the first increment (arrived at from the linear analysis) stresses the material to just below yield in a single step. The model is loaded until a specified displacement is reached at a selected Point. The incrementation strategy is designed to develop the yielded region in a gradual and stable manner.

Stage 3. Contact Analysis with Linear Materials

Once the behaviour of the structure is understood under pressure-loaded conditions, the pressure load is removed. A bolt is added to the model and slidelines are defined to model the contact between the notch and the bolt.

Stage 4. Contact Analysis with Nonlinear Materials

Once the behaviour of the multiple-bodied structure is understood the nonlinear materials in the specimen are re-introduced and a full geometric, nonlinear contact analysis performed.

Stage 1 : Modelling : Linear Material

This worked example will create a LUSAS model of half of the notched V-specimen. Initially, a linear elastic analysis with an applied unit structural face load will be prepared. Then the material properties will be made nonlinear and a suitable analysis control defined and assigned.

Running LUSAS Modeller

For details of how to run LUSAS Modeller see the heading *Running LUSAS Modeller* in the Examples Manual Introduction.



Note. This example is written assuming a new LUSAS Modeller session has been started. If continuing from an existing Modeller session select the menu command **File>New** to start a new model file. Modeller will prompt for any unsaved data and display the New Model dialog.

Creating a new model

- Enter the file name as **vnotch_linear**
- Use the **Default** working folder.

Elasto-Plastic Analysis of a V-Notch

- Enter the title as **V-Notch - Linear Analysis**
- Select the units **N,mm,t,s,C**
- Ensure the **Structural** user interface is being used.
- Select the model template **Standard**
- Select the **Vertical Y axis** option and click **OK**



Note. Save the model regularly as the example progresses. Use the Undo button to correct any mistakes made since the last save was done.

Feature Geometry



Using the X and Y coordinates shown in the table define Points which mark out half of the model. Use the **Tab** key to move to the next entry field. Use the arrow keys to move around fields.

X	Y
90	20
90	30
0	30
0	0
30	0

- Click the **OK** button to finish.



Note. The Z coordinate does not have to be entered. A dimension of zero will be assumed.

The V shaped notch will be created using an arc and a Line drawn tangential to the arc.

- Select the Point shown to generate the arc.

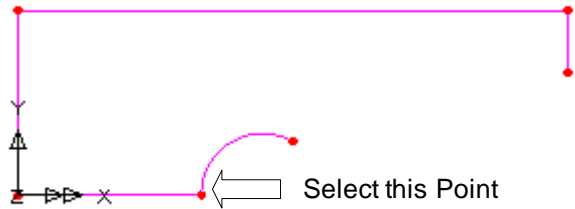

Rotate the Point through an angle of

-120 degrees about an origin of **(40,0)**. Click the **OK** button to finish.

Geometry
Line >
Coordinates...

Geometry
Line >
Arc/Circle >
By Sweeping
Points...

- Select the Point shown and add the Arc to the selection by holding down the **Shift** key.

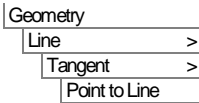
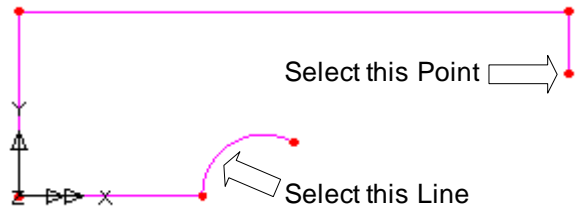

- With **Multiple straight line tangents** selected, ensure that **Split tangent lines** and **Delete geometry on splitting** are also selected on the Straight Line Tangent dialog.

- Click **OK** to draw the Line representing the notch.

The model can now be tidied by deleting the redundant Lines and Points.

- Drag a box to select the features shown.

-  Delete the selected features, confirming that Lines and Points are to be deleted.

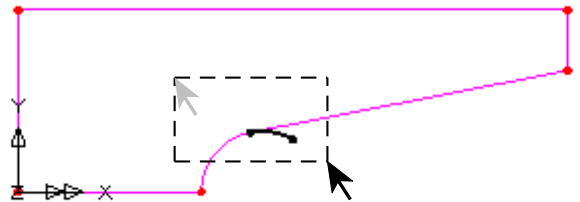

Drag a box to select these features



Note. The Points and Lines used to define features extending outside of the area selected will not be deleted.

Finally, a Surface is to be created from the line features.

- Select the whole model using the **Ctrl** and **A** keys together.

-  Create a **General Surface** from the selected Lines.

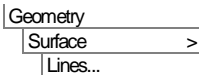
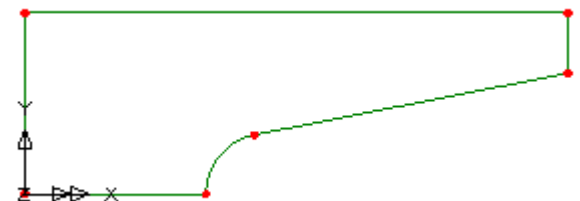

Meshing

- Define **Plane stress**, **Triangle**, **Quadratic** elements with an **Irregular** mesh spacing. Ensure that a specified element size is not selected.

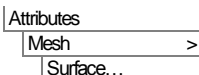

Elasto-Plastic Analysis of a V-Notch

- Enter the mesh attribute name as **Plane Stress TPM6** and click **OK**

LUSAS will add the mesh attribute to the  Treeview.

- Select the newly created surface using the **Ctrl** and **A** keys together. Drag and drop the Surface mesh attribute **Plane Stress TPM6** from the  Treeview onto the selected features. Click **OK** to complete the mesh assignment.

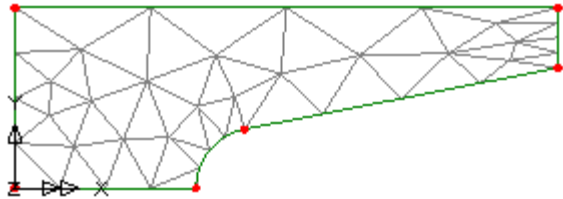

Note. When selecting lines to create a surface, and creating the surface the selection viewed on the screen will still be only the lines and not the new surface. It is for this reason that the whole model (and hence the surface) must be selected again using the Ctrl + A keys as described above.



Note. TPM6 elements are low-order elements and are used in this example to keep within the evaluation version limits. More accurate modelling is obtained when using Plane Stress, Quadrilateral, Quadratic elements (QPM8) which have more nodes per element.

LUSAS will mesh the Surface based upon a default Line division of 4. To improve the shape and arrangement of elements, a Line mesh attribute will be used to control the Surface mesh density.

- With the Structural element type set as **None**, define an average **Element length** of **5 mm**. Enter the Line mesh attribute name as **Element Length 5** and click **OK**
- With the whole model selected, drag and drop the Line mesh attribute **Element Length 5** from the  Treeview onto the selected features.

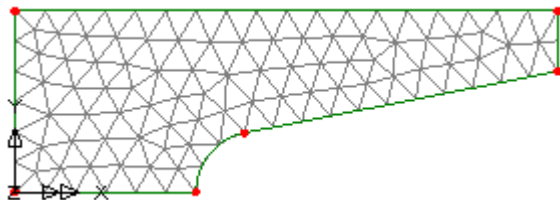

The mesh arrangement will be displayed. Local mesh refinement will now be applied by giving the Arc a finer Line mesh.

- Define an average **Element length** of **2.5 mm**.
- Enter the Line mesh attribute name as **Element Length 2.5** and click **OK**

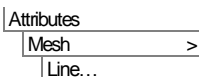
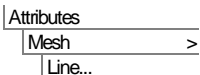

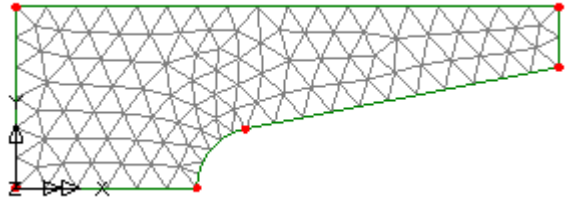

- Select the arc
- Drag and drop the Line mesh attribute **Element Length 2.5** from the  Treeview onto the selected Line.

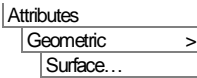

The mesh will be refined as shown.

Geometric Properties



- Define a geometric property attribute with a thickness of **5 mm**.
- Enter the attribute name as **Thickness=5** and click **OK** to add the attribute to the  Treeview.
- With the whole model selected, drag and drop the geometry attribute **Thickness=5** from the  Treeview onto the selected features.





Select the fleshing on/off button to turn-off the automatic geometric property visualisation.

Material Properties

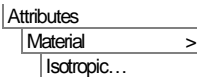
The only material properties that are essential for a linear elastic static analysis are Young's modulus and Poisson's Ratio. The units of Young's modulus in this particular example are N/mm^2 .



- With the **Elastic** tab selected, enter a Young's modulus of **210e3** and a Poisson's Ratio of **0.3**. Leave the other fields blank.
- Enter the attribute name as **Steel (N mm)** and click **OK** to add the attribute to the  Treeview.
- With the whole model selected, drag and drop the material attribute **Steel (N mm)** from the  Treeview onto the selected features and click **OK** to assign to surfaces.

Support Conditions

LUSAS provides the more common types of support by default. These can be seen in the  Treeview. The specimen is to be restrained along the horizontal axis of symmetry in the X and Y axes.

- Select the horizontal Line along the axis of symmetry.
- Drag and drop the support attribute **Fixed in XY** from the  Treeview onto the selected Line and click **OK** to assign to lines.

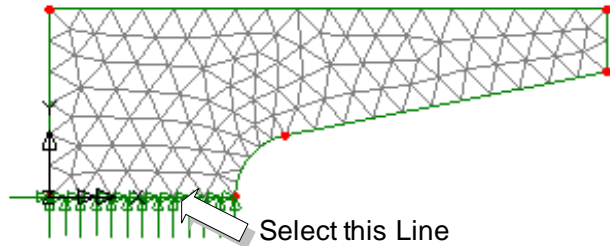

Loading



A unit pressure load is to be defined and applied to the edge of the Surface

- Select the **Face** option and click **Next**
- Define a face load in the **y** direction of **1**
- Enter the attribute name as **Face Load 1** and click **Finish**

 **Note.** Face loads are pressure loads which can be applied to the edges of Surfaces or the faces of Volumes.

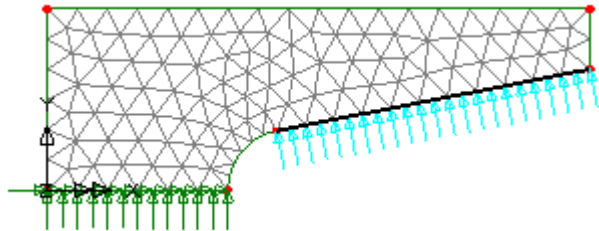
- Select the angled Line of the notch.
- Drag and drop the loading attribute **Face Load 1** from the  Treeview onto the selected Line and click **OK** to assigned to Lines.



 **Note.** Structural face loading uses local element directions. If the loading is incorrectly oriented it may be due to the local element direction of the Surface. To rectify this either reverse the element direction of the Surface by selecting the Surface using **Geometry> Surface> Reverse** or double-click on the loading attribute name in the  Treeview and change the sign of the loading.

Saving the model

 Save the model file.

Running the Analysis : Linear Material

File
LUSAS Datafile...



A LUSAS data file name of **vnotch_linear** will be automatically entered in the File name field.

- Ensure that the options **Solve now** and **Load results** are selected.
- Click the **Save** button to finish.

A LUSAS Datafile will be created from the model information. The LUSAS Solver uses this datafile to perform the analysis.

If the analysis is successful...

The LUSAS results file will be added to loadcase section of the  Treeview.

In addition, 2 files will be created in the directory where the model file resides:



- vnotch_linear.out** this output file contains details of model data, assigned attributes and selected statistics of the analysis.
- vnotch_linear.mys** this is the LUSAS results file which is loaded automatically into the  Treeview to allow results processing to take place.

If the analysis fails...

If the analysis fails, information relating to the nature of the error encountered can be written to an output file in addition to the text output window. Any errors listed in the text output window should be corrected in LUSAS Modeller before saving the model and re-running the analysis.

Rebuilding a Model

If it proves impossible for you to correct the errors reported a file is provided to enable you to re-create the model from scratch and run an analysis successfully.



- vnotch_linear_modelling.vbs** carries out the modelling of the example.

File
New...



Start a new model file. If an existing model is open Modeller will prompt for unsaved data to be saved before opening the new file.

- Enter the file name as **vnotch_linear**

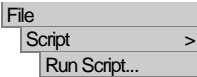

To recreate the model, select the file **vnotch_linear_modelling.vbs** located in the **\<LUSAS Installation Folder>\Examples\Modeller** directory.

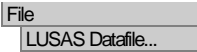



Rerun the analysis to generate the results

Viewing the Results : Linear Material

If the analysis was run from within LUSAS Modeller the results will be loaded on top of the current model and the loadcase results will be seen in the  Treeview.

Deformed Mesh Plot

Once the linear version of the model has been run it is prudent to check the deformed shape for obvious errors such as overlarge displacements in unexpected areas, which could be accounted for by incorrect properties, incorrect positioning of the load or incorrect support conditions. The deformed shape also provides a general check on the overall load direction.

- If present in the  Treeview turn off the **Mesh**, **Geometry** and **Attributes** layers by right-clicking on a layer name and selecting the On/Off menu item..
- With no features selected click the right-hand mouse button in a blank part of the Graphics window and select the **Deformed mesh** option to add the deformed mesh layer to the  Treeview.
- Click the **OK** button to display the deformed mesh plot.

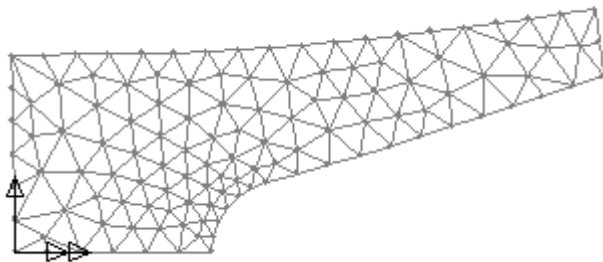

Von Mises Stress Contours

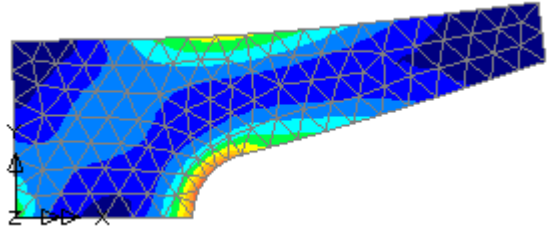

The linear elastic results provide an opportunity to establish a faster loading scheme for the nonlinear analysis to come. Checking the maximum von Mises stress values will allow calculation of a factor of load that can be sustained without yielding the material.

- With no features selected click the right-hand mouse button in a blank part of the Graphics window and select the **Contours** option to add the contour layer to the  Treeview.
- Select entity **Stress - Plane Stress** and component equivalent stress **SE**
- Click the **OK** button to display the contours.



Changing the layer display order



Note. The order of the layer names in the  Treeview determines the order in which the layers will be displayed. To make a layer display after another layer, click on the layer name in the  Treeview and drag the layer name onto the layer name after which it is to be displayed. The display in the graphics window will be updated accordingly.

- Following the note above make the deformed mesh display after the contours by dragging the **Deformed Mesh** layer onto **Contours** layer in the  Treeview.



Note. The material chosen for the analysis is assumed to yield at 300 N/mm^2 . From the contour key results the maximum stress induced from a unit face load results in a stress of just over 30 N/mm^2 . Therefore, a factored load value of 9 would be suitable for use as the first load increment level in the nonlinear analysis as this would result in stresses just below the yield stress.

This completes the linear analysis stage of the example.

Stage 2 : Modelling : Nonlinear Material

For software product(s):	Any Plus version.
With product option(s):	Nonlinear.

Files. The geometry of the notch is the same as that defined for the linear model. It may be recovered by one of two methods; either by loading the previously created model file, and by creating the initial model from a supplied file as described below.



If the previous linear analysis was performed successfully open the model file **vnotch_linear.mdl** which was saved after completing the first part of this example and select **No** to not load a results file of the same name on top of this model.

- Enter the model file name as **vnotch_nonlinear** and click the **Save** button.

Creating the initial model from a supplied file



Alternatively, start a new model file. If an existing model is open Modeller will prompt for unsaved data to be saved before opening the new file.

- Enter the file name as **vnotch_nonlinear**

To create the model, select the file **vnotch_linear_modelling.vbs** located in the **\<LUSAS Installation Folder>\Examples\Modeller** directory.

Change the model description

Change the model description to **V-Notch - Nonlinear Analysis** and click **OK**

Modifying the Material

The linear material dataset needs to be modified to include plastic properties.

- In the  Treeview double-click on the material attribute **Steel (N mm)**
- Select the **Plastic** check box and for a **Stress potential** model enter an **Initial uniaxial yield stress** of **300**
- Select the **Hardening** check box, select the **Hardening gradient** option and enter a **Slope** of **0** and a **Plastic strain** of **1000** in the first row of the table.
- Click the **OK** button to finish and overwrite the existing material dataset.



Note. The von Mises material model used assumes identical behaviour in compression and tension.

Nonlinear Analysis Control

From the results of the Linear analysis, initial yielding is expected at a load factor of nearly 10 (Yield Stress/Max Stress). Therefore the nonlinear loading strategy will be to apply an initial load factor of 9, and use unit factor increments as the yielding progresses. The analysis will be set to stop once the Point at the inside end of the arm of the notch has displaced 10mm from its original position.

- Ensure that the geometry layer is present in the  Treeview and turned On.
- Select the Point at the end of the notch as shown.



Note. The number of the Point selected will be displayed in the status bar at the bottom of the graphics window.

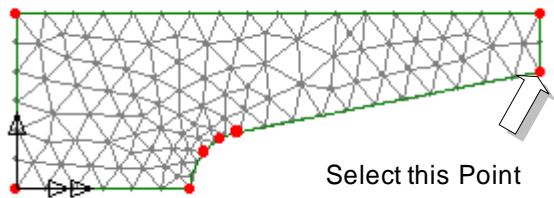

Nonlinear analysis control options are defined as properties of a loadcase.

- In the  Treeview right-click on **Loadcase 1** and select **Nonlinear and Transient** from the **Controls** menu.

The Nonlinear & Transient dialog will appear.

- Select the **Nonlinear** option.
- From the **Incrementation** drop down list select **Automatic** control.
- Set the **Starting load factor** as **9**
- Set the **Max change in load factor** as **1**
- Set the **Max total load factor** as **0** to enable the load to increase without limit.

The dialog should appear as shown:

Nonlinear & Transient

Incrementation

Nonlinear

Incrementation: Automatic

Starting load factor: 9

Max change in load factor: 1

Max total load factor: 0

Adjust load based on convergence

Iterations per increment: 4

Advanced...

Solution strategy

Same as previous loadcase

Max number of iterations: 12

Residual force norm: 0.1

Incremental displacement norm: 1.0

Advanced...

Time domain

Time domain

Consolidation

Initial time step: 0.0

Total response time: 100.0E6

Automatic time stepping

Advanced...

Incremental LUSAS file output

Same as previous loadcase

Output file: 1

Plot file: 1

Restart file: 0

Max number of saved restarts: 0

Log file: 1

History file: 1

Common to all

Max time steps or increments: 0

OK Cancel Help

To terminate the load on a limiting variable the advanced nonlinear parameters need to be set in the Incrementation section.

- Select the Incrementation **Advanced** button.
- Click the **Terminate on value of limiting variable** option.
- Set the **Point number** from the drop-down list to the Point selected earlier.
- Set the **Variable type** in the drop down list as **V** to limit the displacement in the local Y direction.
- Set the **Value** as **10**
- Ensure the **Allow step reduction** option is ticked.

The dialog should appear as shown below.

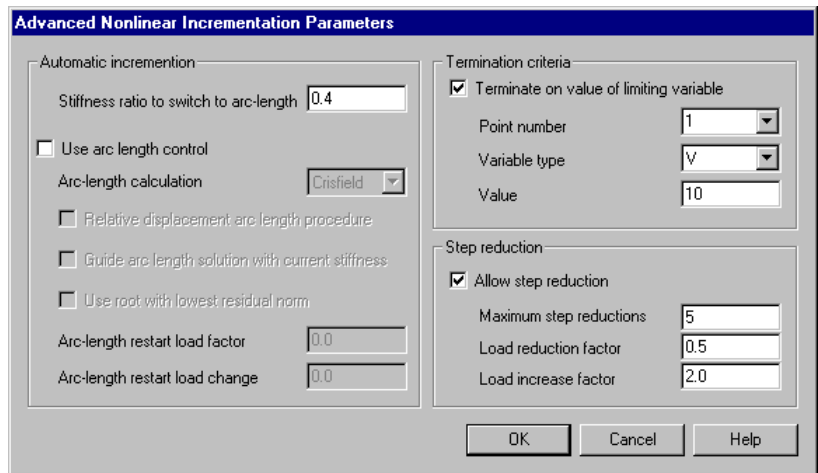

- Click the **OK** button to return to the load case dialog.
- Click the **OK** button to finish.

Save the model



To save the model.



Note Geometric stiffening is not considered in this example because the nonlinear effects are predominantly due to yield in the material.

Running the Analysis : Nonlinear Material



A LUSAS data file name of **vnotch_nonlinear** will be automatically entered in the File name field.

- Ensure that the options **Solve now** and **Load results** are selected.
- Click the **Save** button to finish.

A LUSAS Datafile will be created from the model information. The LUSAS Solver uses this datafile to perform the analysis.

During the analysis...

Apart from the increment and iteration, several parameters output are of special interest during the nonlinear analysis phase:

- TLMDA (Total Load Factor)** The factor of load applied using the incrementation control is displayed here. It shows how the load application is progressing for a load control and an arc-length solution.
- DTNRM (Displacement Norm)** The changes in this value indicate how well the problem is converging.

If the analysis is successful...

The LUSAS results file will be added to the  Treeview.

In addition, 2 files will be created in the directory where the model file resides:



- vnotch_nonlinear.out** this output file contains details of model data, assigned attributes and selected statistics of the analysis.
- vnotch_nonlinear.mys** this is the LUSAS results file which is loaded automatically into the  Treeview to allow results processing to take place.

If the analysis fails...

If errors are listed that for some reason you cannot correct, a file is provided to re-create the model information correctly, allowing a subsequent analysis to be run successfully.



- vnotch_nonlinear_modelling.vbs** carries out the complete nonlinear material modelling of the example.



Start a new model file. If an existing model is open Modeller will prompt for unsaved data to be saved before opening the new file.

- Enter the file name as **vnotch_nonlinear**

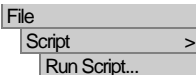

To re-create the model, select the file **vnotch_nonlinear_modelling.vbs** located in the **\<LUSAS Installation Folder>\Examples\Modeller** directory.

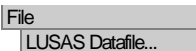

Rerun the analysis to generate the results

Viewing the Results : Nonlinear Material

This section covers a typical results processing session for a nonlinear analysis. In this session the following procedures will be carried out:

- A von Mises stress contour plot and associated yielded region plot will be drawn.
- A graph showing the displacement history of the notch opening through the analysis will be created.

If the analysis was run from within LUSAS Modeller the results will be loaded on top of the current model and the load case results for loading increment 1 will be set active by default.

Plotting Stress Contours

- In the  Treeview ensure that the **Contours** and **Deformed mesh** layers are present and are turned On.
- Double click on the **Contours** entry to show its property dialog and select entity **Stress - Plane Stress** and component equivalent stress **SE**
- Click the **Contour Range** tab and set the **Maximum** stress contour value to be plotted as **300** so all stresses above yield are drawn in red.
- Click the **OK** button to display contours for the first load increment.
- With no features selected click the right hand mouse button in a blank part of the graphics window and select the **Mesh** layer.
- Select **OK** to accept the default properties and add the mesh to the display.

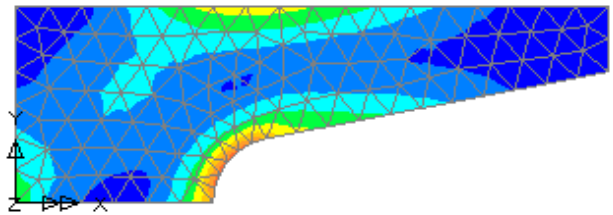

The display will show that the yield stress of 300Nmm^{-2} has not been reached after the first loading increment.

Changing the Active Results Loadcase

- In the Treeview, right-click on the last load increment and select the **Set Active** option.

Contours for the selected increment will be displayed.. The red

area shows the peak von Mises stress which is being limited to 300 N/mm^2 by the zero hardening slope as defined in the plastic material properties section for the model.

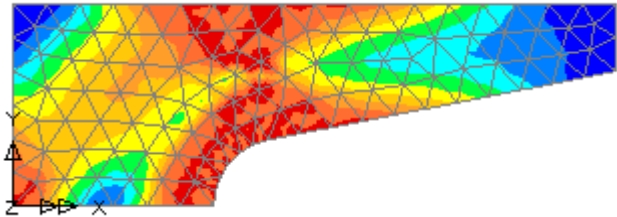

Yielded Material Plot

In addition to using contours to show yielded regions of the model, the spread of plasticity can be visualised using yield symbols.

- With no features selected click the right hand mouse button in a blank part of the graphics window and select the **Values** layer.
- Select the **Stress - Plane Stress** entity and **Yield** component and click the **OK** button to display the yielded Gauss points with an asterisk.

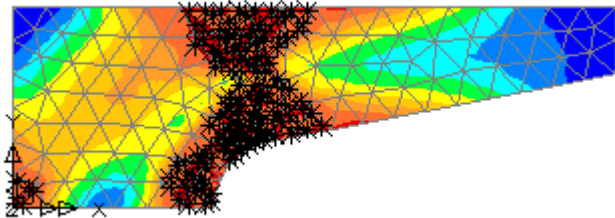

Note. By changing the active loadcase the spread of yield through the model can be viewed.

Displacement History Graph

To illustrate the nonlinear behaviour of the model a displacement history graph showing the displacement of a node on the notch against the total applied load factor is to be displayed.

- Select the node on the end of the notch as shown.

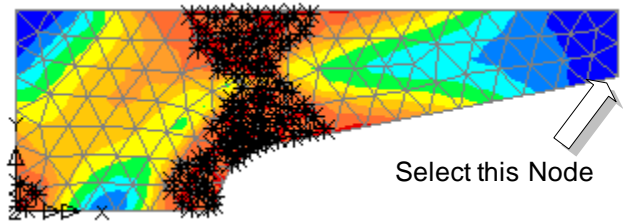

The graph wizard provides a step-by-step means of selecting which results are to be plotted on the X and Y axes of the graph. The X axis is always defined first.

Utilities

Graph Wizard...

- Ensure the **Time history** option is selected and click the **Next** button.
- Ensure the **Nodal** results button is selected for the X axis results and click the **Next** button.
- Select **Displacement** from the entity drop down list for the component **DY**. The node number of the selected node will be shown. Click the **Next** button.

This defines the X axis results.

- Select **Named** results and click the **Next** button.
- From the drop down list select **Total Load Factor** data and click the **Next** button.

This defines the Y axis results.

- Leave all title and axis fields blank and click the **Finish** button to create the graph in a new window and display the values used in an adjacent table.

 To see the graph at the best resolution enlarge the window to a full size view.

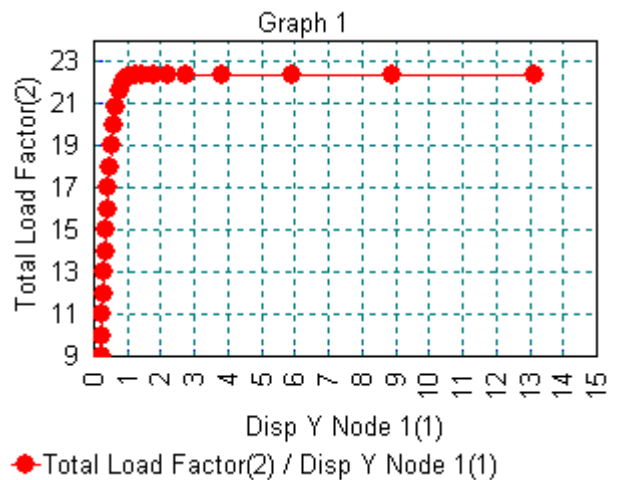



Note. The graph shows the progressive softening of the structural response as the load is increased. The load value corresponding to the flat section represents the limit of the load carrying capacity of the model.



Delete the graph window.

Stage 3: Modelling : Contact Analysis (Linear Material)

For software product(s):	Any Plus version.
With product option(s):	Nonlinear.
Note: This stage exceeds the limits of the LUSAS Teaching and Training Version.	

This section details the changes required to the linear material model from the first part of the example to incorporate the geometry of a bolt which will be positioned and loaded to prise the notch arms apart.

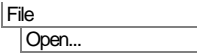

If the initial linear analysis was performed successfully open the model file **vnotch_linear.mdl** saved after completing the first part of this example and select **No** to not load a results file of the same name on top of this model.

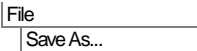

- Enter the model file name as **vnotch_contact** and click the **Save** button.

Creating the starting model from a supplied file

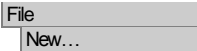

Alternatively, start a new model file. If an existing model is open Modeller will prompt for unsaved data to be saved before opening the new file.

- Enter the file name as **vnotch_linear_contact**

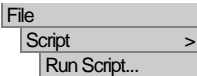

To create the model, select the file **vnotch_linear_modelling.vbs** located in the **\<LUSAS Installation Folder>\Examples\Modeller** directory.



- Change the model description to **V-Notch - Contact Analysis (Linear Material)** and click **OK**
- In the  Treeview ensure that the **Geometry** and **Attributes** layers are present and are turned On.

Deassigning the Loading

The initial pressure loading is no longer required. In the nonlinear contact model the loading will be applied as a prescribed displacement to the centre-line of the bolt.

- In the  Treeview click the right hand mouse button on the loading attribute **Face Load 1** and select the **Deassign > From all** option.

Modelling the Bolt



Note. At this stage the bolt will be defined separated from the notch specimen. This will make assigning the attributes, especially the slidelines, easier. Once the attributes are assigned, the bolt will be moved to its starting position before the analysis is run.

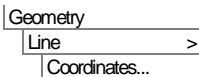

 Enter coordinates of **(75,0)**, **(90,0)** and **(105,0)** and click **OK** to define 2 horizontal Lines on the bolt centreline.

 Enter coordinates of **(90,0)** and **(90,15)** and click **OK** to define a vertical Line on the bolt centreline.

An arc is to be drawn to form the upper half of the bolt.

- Select the 3 Points in the order shown.
- Click **OK** to accept the values present on the dialog and the arc will be drawn.

2. Select this Point

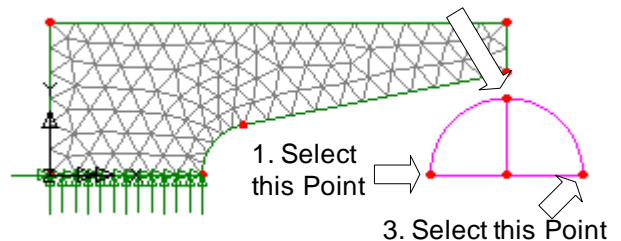

1. Select this Point

3. Select this Point

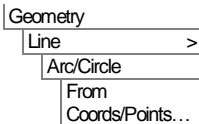

This arc will now be split into 2 new arcs.

- Select the arc just drawn
- Enter the number of divisions as **2**
- Click **OK** to create 2 arcs and delete the original arc.

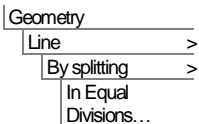

Surfaces will now be defined on the bolt.

- Select the left hand arc and then the 2 Lines as shown.



 The left hand Surface of the bolt will be drawn.

- Select the right-hand arc and then the other 2 Lines to create the Surface for the other half of the bolt.

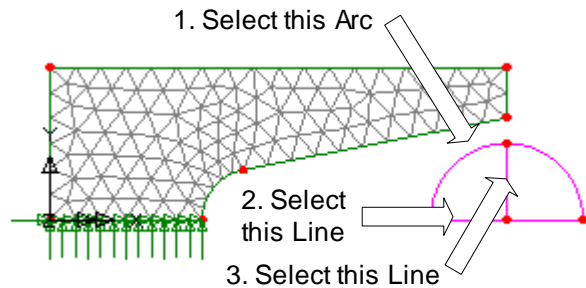
 The right-hand Surface of the bolt will be drawn.



Meshing the Bolt

- In the  Treeview double-click on the mesh attribute **Plane Stress TPM6**
- Change the element shape to **Quadrilateral**, select **Regular Mesh**, and change the attribute name to **Plane Stress Quads**.
- Click the **OK** button to create a new mesh dataset in the  Treeview.
- Select both Surfaces defining the bolt and drag and drop the surface mesh dataset **Plane Stress Quads** from the  Treeview onto the selected features.

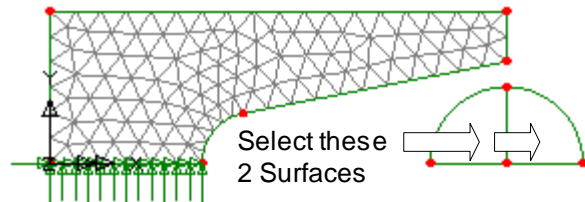

Modifying the mesh on the bolt

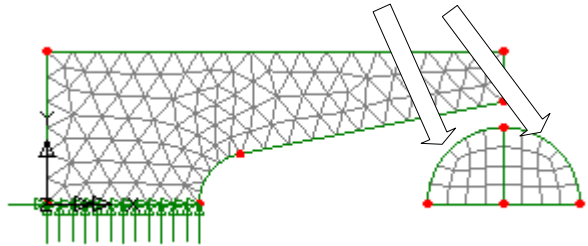

- Select the 2 arcs at the top of the bolt as shown.
- Drag and drop the line mesh attribute **Divisions=6** from the  Treeview onto the selected Lines.

Select these 2 Lines for 'Divisions = 6'



The mesh will be redrawn as shown.

Geometric Properties

- In the  Treeview double click on the geometry attribute **Thickness=5**
- Change the thickness to **10** and change the attribute name to **Thickness=10**
- Click the **OK** button to create a new geometric mesh attribute in the  Treeview.
- Select both Surfaces of the bolt and drag and drop the geometry attribute **Thickness=10** from the  Treeview onto the selected features.

Material Properties

- With the bolt selected, drag and drop the material attribute **Steel (N mm)** from the  Treeview onto the selected features.



Note. At this stage the material model is linear elastic and does not include plasticity effects. The addition of plasticity is included at the next stage of the example.

Support Conditions

A roller support is required at the bolt centreline to restrain in the Y direction only.

Elasto-Plastic Analysis of a V-Notch

- Select the 2 horizontal Lines on the bolt centreline.
- Drag and drop the support attribute **Fixed in Y** from the  Treeview onto the selected lines.

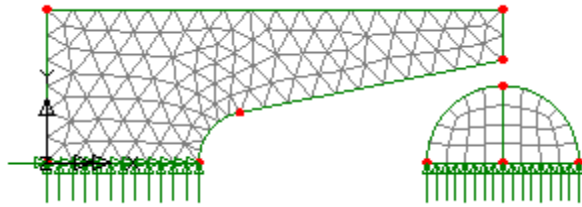

- Click **OK** to assign the support dataset to the selected Lines.

Loading Conditions

An incremental prescribed displacement will be used. At this stage a negative unit displacement will be applied. The magnitude of each increment is controlled later using nonlinear control parameters.

- Select the **Prescribed Displacement** option and click **Next**
- Select the **Incremental** button and enter a prescribed displacement in the **X** direction of **-1**
- Enter the attribute name as **Prescribed Load 1** and click **Finish**

- With the 2 horizontal Lines on the bolt centreline selected, drag and drop the loading dataset **Prescribed Load 1** from the  Treeview onto the selected features.

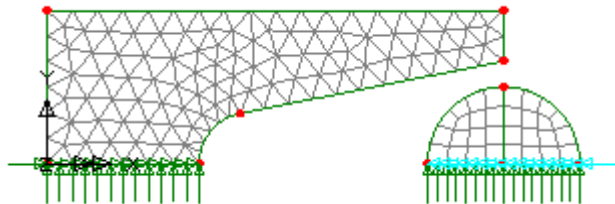

- Click **OK** to assign the loading to **Loadcase 1** with a factor of **1**

Slideline Definition

Slidelines automatically model components having dissimilar meshing patterns and can also model any frictional contact between interacting components. Slidelines are to be applied to the contacting Lines of the notch and the bolt.

- Ensure the **Master Stiffness Scale** and **Slave Stiffness Scale** values are set to **1** and leave the remaining values as defaults.

Attributes
Loading...

Attributes
Slideline...

- Enter the slideline attribute name as **Slideline 1** and click **OK** to add the slideline attribute to the  Treeview.

The Coulomb friction coefficient defaults to zero, which will define a standard no friction slideline.

- Select the inclined Line of the notch.

Select this Line for the Master

- Drag and drop the slideline attribute **Slideline 1** from the  Treeview onto the selection.

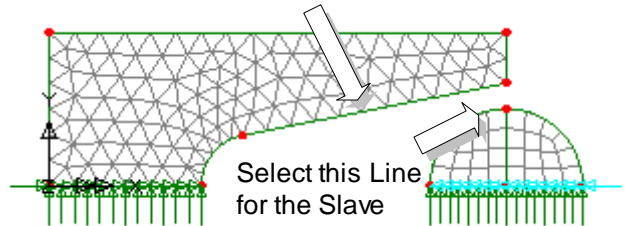

- Ensure the **Master** option is selected and click **OK** to accept the default orientation.

- Select the left arc of the bolt.

- Drag and drop the slideline attribute **Slideline 1** from the  Treeview onto the selection.

- Select the **Slave** option and click the **OK** button to accept the default orientation.

- To visualise the slidelines assigned to the model click the right-hand mouse button on the slideline attribute name in the  Treeview and select

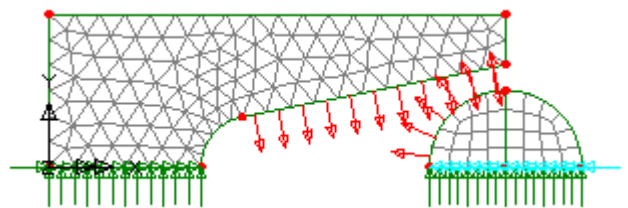



Visualise MasterAssignments and **Visualise Slave Assignments**

- Repeat the process above to deselect the slideline visualisation.

All assignments are now complete, and the bolt can be moved into a starting position just adjacent to the notch ready for the analysis.

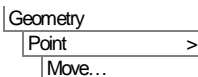
- Drag a selection box around the bolt.



-  Enter a translation of **-24** in the **X** direction.

Elasto-Plastic Analysis of a V-Notch

- Leave the attribute name blank and click the **OK** button to move the bolt into position.

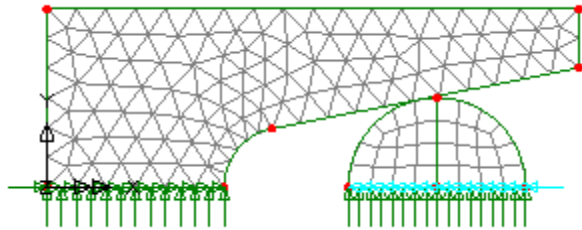

Nonlinear Analysis Control

A bolt displacement of 1mm is to be specified. This will be done in 10, 0.1mm increments using nonlinear control properties. The nonlinear analysis control parameters are applied as properties of the loadcase.

- In the  Treeview right-click on **Loadcase 1** and select **Nonlinear and Transient** from the **Controls** menu.

The Nonlinear & Transient dialog will appear.

- Set **Nonlinear** incrementation with **Automatic** control.
- Set the **Starting load factor** as **0.1**
- Set the **Maximum change in load factor** as **0.1**
- Set the **Maximum total load factor** as **1**
- Deselect the option to **Adjust load based upon convergence**
- Click the **OK** button to finish the definition of the nonlinear parameters.

Saving the model

File
Save



To save the model.

Running the Analysis : Contact Analysis (Linear Material)

With the model loaded:

File
LUSAS Datafile...



A LUSAS data file name of **vnotch_linear_contact** will be automatically entered in the Filename field.

- Ensure that the options **Solve now** and **Load results** are selected.

- Click the **Save** button to finish.

A LUSAS Datafile will be created from the model information. The LUSAS Solver uses this datafile to perform the analysis.

If the analysis is successful...

The LUSAS results file will be added to the  Treeview.

In addition, 2 files will be created in the directory where the model file resides:



- vnotch_linear_contact.out** this output file contains details of model data, assigned attributes and selected statistics of the analysis.
- vnotch_linear_contact.mys** this is the LUSAS results file which is loaded automatically into the  Treeview to allow results processing to take place.

If the analysis fails...

If errors are listed that for some reason you cannot correct, a file is provided to re-create the model information correctly, allowing a subsequent analysis to be run successfully.



- vnotch_linear_contact_modelling.vbs** carries out the modelling of the example.

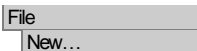

Start a new model file. If an existing model is open Modeller will prompt for unsaved data to be saved before opening the new file.

- Enter the file name as **vnotch_linear_contact**

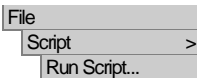

To recreate the model, select the file **vnotch_linear_contact_modelling.vbs** located in the **\<LUSAS Installation Folder>\Examples\Modeller** directory.

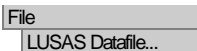

Rerun the analysis to generate the results

Viewing the Results - Contact Analysis (Linear Material)

If the analysis was run from within LUSAS Modeller the results will be loaded on top of the current model and the loadcase results for each load increment can be seen in the  Treeview. The results for load increment 1 are set to be active by default.



Equivalent Stress Contour Plots

If present in the  Treeview turn off the **Mesh**, **Geometry** and **Attributes** layers.

- With no features selected click the right-hand mouse button in a blank part of the graphics window and select **Deformed mesh** to add the deformed mesh layer to the  Treeview.
- On the deformed mesh dialog, click the **Specified factor** option and enter a **Factor** of **1** and click the **OK** button.



Note. When viewing results for contacting components it is important that the deformed mesh is plotted using a specified factor of 1 rather than a specified magnitude otherwise the components appear to contact incorrectly.

- With no features selected click the right-hand mouse button in a blank part of the Graphics window and select the **Contours** option to add the contours layer to the  Treeview and display the contour properties.
- On the contour properties dialog select entity **Stress - Plane Stress** and component equivalent stress **SE** from the contour property dialog.
- Click the **Contour range** tab and set the **Maximum** stress contour value to be plotted as **300** so all stresses above yield will be drawn in red.
- Click the **OK** button to display the contours and contour key for the first load increment.
- In the  Treeview drag the **Deformed Mesh** layer onto the **Contours** layer.

The contour arrangement shows that the first load increment does not induce any stresses in the arms of the notch since contact has not yet taken place.

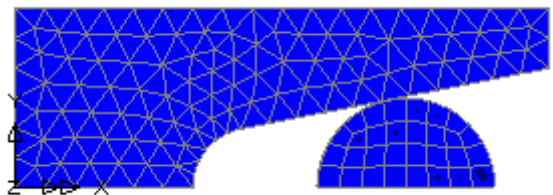

Changing the Active Results Loadcase

- In the  Treeview right-click on the last load increment for load factor 1.0 and select the **Set Active** option.

The contour plot for the final increment will be displayed.

From this stress plot where the bolt displacement is 1mm, it can be seen from the contour key that the material in the root of the notch is stressed to levels above the yield value of the material.

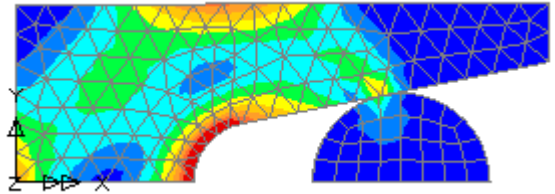

Note. By investigating the other load increments it can be seen that after the third load increment the bolt begins to induce stresses in the notch and that the load is transferred from the bolt to the specimen via the slidelines.

Stage 4: Modelling : Contact Analysis (Nonlinear Material)

For software product(s):	Any Plus version.
With product option(s):	Nonlinear.
Note: This stage exceeds the limits of the LUSAS Teaching and Training Version.	

Creating the Model



Files. The geometry of the notch lug is the same as that defined for the geometrically nonlinear contact analysis model. It may be recovered by one of two methods.



If the linear contact analysis was performed successfully re-open the model file **vnotch_contact.mdl** and select **No** to not load a results file of the same name on top of this model.

- Enter a model file name of **vnotch_nonlinear_contact** and click the **Save** button.

Creating the starting model from a supplied file



Alternatively, start a new model file. If an existing model is open Modeller will prompt for unsaved data to be saved before opening the new file.

- Enter the file name as **vnotch_nonlinear_contact**

To create the model, select the file **vnotch_linear_contact.vbs** located in the **\<LUSAS Installation Folder>\Examples\Modeller** directory.

File
Open...

File
Save As...

File
New...

File
Script >
Run Script...

Changing the model description

- Change the model description to **V-Notch - Contact Analysis (Nonlinear Material)** and click **OK**

Modifying the Geometry

The linear material attribute needs to be modified to include plastic properties.

- In the  Treeview double-click on the material attribute **Steel (N mm)**
- Select the **Plastic** button and enter an **Initial uniaxial yield stress** of **300**
- Select the **Hardening** button, select the **Hardening gradient** button and enter a **Slope** of **0** and a **Plastic strain** of **1000** in the first line of the table.
- Click the **OK** button to overwrite the existing material definition.



Note. The perfectly plastic assumption is an initial simplification that would in practice be replaced by a more detailed description of the hardening behaviour of the material. This would typically involve specifying several hardening gradients (i.e nonlinear hardening) and the strain limits to which each slope applies.

Nonlinear Analysis Control

The nonlinear control properties required for this section of the analysis are already specified in the current model. However, the bolt displacement of 1mm is to be increased to 2.5mm by specifying 25, 0.1mm increments in the nonlinear section of the load case dialog.

- In the  Treeview double-click on **Nonlinear and Transient** to edit the existing parameters.
- Set the **Max total load factor** to **2.5**
- Click the **OK** button to return to the graphics window.

Save the model



Save the model.

Running the Analysis : Contact Analysis (Nonlinear Material)

File
LUSAS Datafile...



A LUSAS data file name of **vnotch_nonlinear_contact** will be automatically entered in the File name field.

- Ensure that the options **Solve now** and **Load results** are selected.
- Click the **Save** button to finish.

A LUSAS Datafile will be created from the model information. The LUSAS Solver uses this datafile to perform the analysis.

If the analysis is successful...

The LUSAS results file will be added to Load Case section of the  Treeview.

In addition, 2 files will be created in the directory where the model file resides:



- vnotch_nonlinear_contact.out** this output file contains details of model data, assigned attributes and selected statistics of the analysis.
- vnotch_nonlinear_contact.mys** this is the LUSAS results file which is loaded automatically into the  Treeview to allow results processing to take place.

If the analysis fails...

If errors are listed that for some reason you cannot correct, a file is provided to recreate the model information correctly, allowing a subsequent analysis to be run successfully.



- vnotch_nonlinear_contact_modelling.vbs** carries out the complete modelling of the example.

File
New...



Start a new model file. If an existing model is open Modeller will prompt for unsaved data to be saved before opening the new file.

- Enter the file name as **vnotch_nonlinear_contact**

File
Script >
Run Script...

To recreate the model, select the file **vnotch_nonlinear_contact_modelling.vbs** located in the **\<LUSAS Installation Folder>\Examples\Modeller** directory.

File
LUSAS Datafile...



Rerun the analysis to generate the results

Viewing the Results : Contact Analysis (Nonlinear Material)



If the analysis was run from within LUSAS Modeller the results will be loaded on top of the current model and the loadcase results for each load increment can be seen in the  Treeview. Load increment 1 is set to be active by default.

Changing the Active Results Loadcase

- In the  Treeview right-click on the last load increment (for load factor 2.5) and select the **Set Active** option.

Preparing to animate the spread of yielded material

As an alternative to viewing results individually for each loadcase, the change of stress and the spread of yielded material due to the increasing load increments can be animated instead. Stress contours and yield symbols will be plotted for selected load increments.

- If present, turn off the **Mesh**, **Geometry** and **Attributes** layers in the  Treeview.
- With no features selected click the right-hand mouse button in a blank part of the graphics window and select the **Deformed mesh** option to add the deformed mesh layer to the  Treeview.
- On the Deformed mesh dialog click the **Specify factor** option and enter a Factor of **1** and click the **OK** button.



Note. When animating nonlinear loadcases it is important that the deformed mesh is plotted using a specified factor of 1 and not using a fixed screen size value of magnitude otherwise the deformed mesh for each load increment would be drawn the same.



- With no features selected click the right-hand mouse button in a blank part of the graphics window and select **Contours** to add the contours layer to the  Treeview.

The contour plot properties will be displayed.

- Select **Stress - Plane Stress** contour results of Equivalent stresses **SE**
- Select the **Contour Range** tab and set the **Maximum** contour value as **300**
- Click the **OK** button.

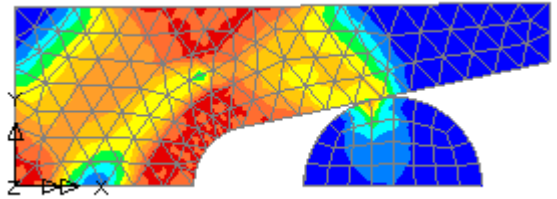
The contour plot and contour summary for load increment 25 will be displayed showing the region of yielded material has spread across the whole arm of the model.



- If necessary, change the layer display order to display the deformed mesh on top of the contour plot by moving the **Deformed mesh** to follow **Contours** in the  Treeview.
- With no features selected click the right-hand mouse button in a blank part of the graphics window and select **Values** to add the values layer to the  Treeview.

The values layer properties dialog will be displayed.

- Select **Stress - Plane Stress** values of component **Yield**
- Click the **OK** button to display yield symbols for load increment 25 to show areas of the model that have yielded.

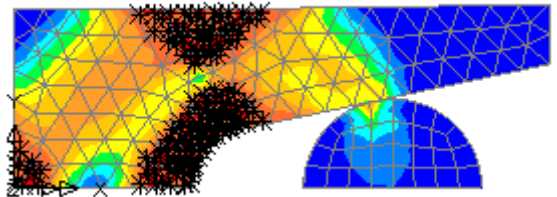

Animating the results

Utilities

Animation Wizard...

- Select the **Load history** option and click the **Next** button.
- Select **vnotch_nonlinear_contact.mys** from the drop-down menu.

The list of available load cases for selection will appear.



Note. With so many load increments there is no need to animate the whole sequence. The selected load cases can be filtered to reduce the number to be animated.

- Enter a **Step** value of **4** to display every fourth increment and click the **Filter** button.

The filtered load increments will displayed in the loadcase panel.

- Select the first load increment, hold down the **Shift** key and select the last load increment.

- Click the  button to add the selected load increments to the included panel for the animation sequence.
- Click the **Finish** button to create the animation sequence and display the animation in a new window.



Note. To see the animation at the best resolution enlarge the window to a full size view. The buttons at the bottom of the window may be used to slow-down, speed-up, pause, step through frame by frame, or stop the animation.

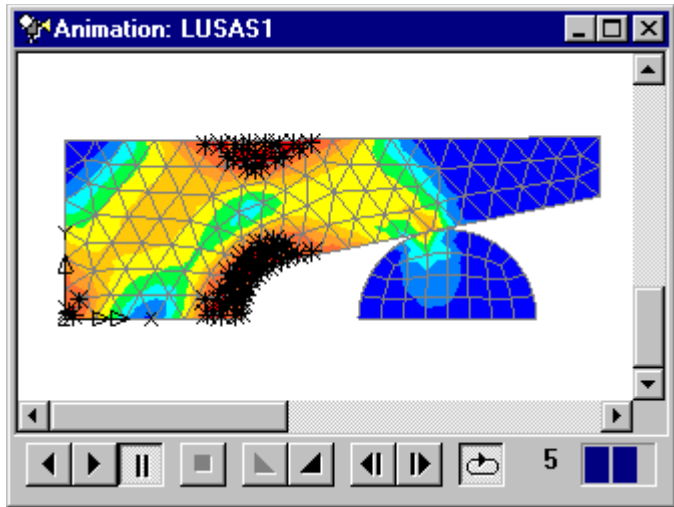

Saving Animations

Animations may be saved for replay in LUSAS at any time or saved for display in other windows animation players.

- Ensure the animation window is the active window.
- Enter **vnotch_nonlinear_contact** for the animation file name. An **.avi** file extension is automatically appended to the file name when it is saved.
- Animations can be compressed to save disk space. A number of compression formats are available depending on what is installed on the system. **Microsoft Video 1** has been found to provide reliable results.
- Click **OK** to create the animation file.

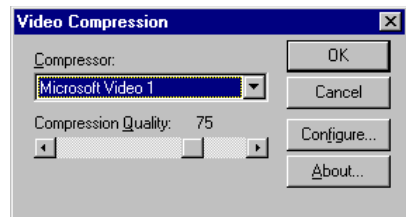

This completes the example.

File
Save As AVI...

Modal Analysis of a Tuning Fork

For software product(s):	All (except LT versions)
With product option(s):	None.
Note: The example exceeds the limits of the LUSAS Teaching and Training Version.	

Description

This example demonstrates a natural frequency analysis of a stainless steel tuning fork. The dimensions are those of an A tuning fork which vibrates at 440 Hz. The overall dimensions of the fork are as shown.

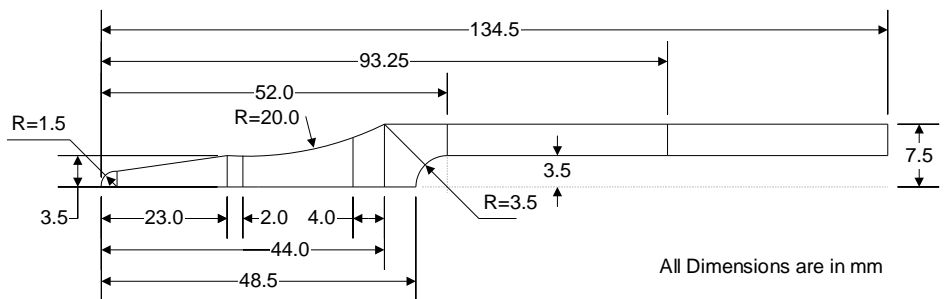

Units of N, mm, t, s, C are used throughout.

- For natural frequency analysis consistent units must be adopted.
- A model for an eigenvalue analysis is created in an identical way to that required for a static analysis, using features and attributes, but a relatively coarse mesh is used since stress output is not required.
- No loading is applied to the structure.
- Eigenvalue control data is included to specify details of the analysis required.

In a natural frequency analysis the following assumptions are made:

- There is no applied load and vibration is due to the mass and stiffness of the structure alone.
- There is no damping.
- Vibration assuming sinusoidal displacements of the form $a = A\sin(\omega t)$.

The numerical solution produces a series of eigen pairs. The eigenvalues which indicate frequencies at which the vibration would naturally occur are output. The eigenvectors give the associated mode shape of vibration. It is important to note that the solved eigenvectors (and hence the resulting mode shape displacements) are normalised and hence may be arbitrarily scaled. Although displacement, strain and stress information may be plotted, these quantities are therefore only relative and cannot be used directly in the design process. It is common for the magnitudes of these quantities to be investigated by running subsequent modal analyses such as forced (harmonic) or spectral (seismic) response. In this case the resulting eigenvalues will be manipulated interactively during results processing using the Interactive Modal Dynamics (IMD) facility.

The default method for Eigenvalue Extraction, used here, is Subspace Iteration. This method has the following characteristics:

- All of the degrees of freedom in the model are used in the solution.
- An initial estimated solution is improved via subsequent iterations.

These characteristics make the method very accurate and robust.

Keywords

2D, Intersecting Features, Splitting Features, Surfaces by Joining, Mirroring, Natural Frequency, Eigenvalue, Eigenvalue Control, Interactive Modal Dynamics (IMD), Mode Shapes, Animation, Frequency Response Graphs.

Associated Files



- fork_modelling.vbs** carries out the modelling of the fork.

Modelling

Running LUSAS Modeller

For details of how to run LUSAS Modeller see the heading *Running LUSAS Modeller* in the Examples Manual Introduction.



Note. This example is written assuming a new LUSAS Modeller session has been started. If continuing from an existing Modeller session select the menu command **File>New** to start a new model file. Modeller will prompt for any unsaved data and display the New Model dialog.

Creating a new model

- Enter the file name as **fork**
- Use the **Default** working folder.
- Enter the title as **Tuning Fork - Frequency Analysis**
- Set the units to **N,mm,t,s,C**
- Ensure the **Structural** user interface is selected.
- Select the model template **Standard**
- Select the **Vertical Y Axis** option and click the **OK** button.



Note. Save the model regularly as the example progresses. Use the Undo button to correct any mistakes made since the last save was done.

Feature Geometry

- Enter coordinates of **(0, 0)**, **(1.5, 0)**, and **(1.5, 1.5)** to define the arc at the far left end of the fork. Select the coordinate **(1.5, 0)** as the **Centre** of the arc and click **OK**

- Drag a box to select the 2 Points shown.



Use the New Line button to create the Line.

- Select the other 2 Points shown.



Use the New Line button to create the Line.

- Select the Arc, hold down the **Shift** key and then select the 2 straight Lines by individually clicking on each in turn.



Using the New Surface button, create a Surface from the Lines selected.

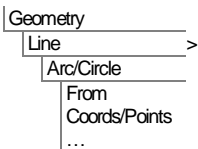
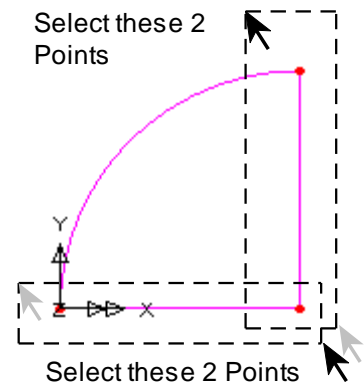

Modal Analysis of a Tuning Fork

- Click on a blank part of the graphics window to clear the selection.

 Define Points at coordinates of **(23,0)** and **(23,3.5)** and click **OK**

- Select pairs of Points and create new Lines between each pair.
- Drag a box around these Lines.

 Create a Surface to form the next part of the base of the fork.

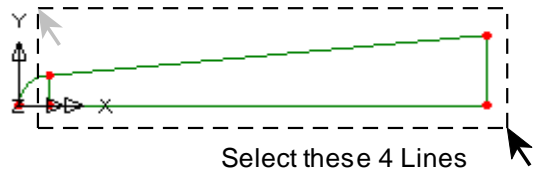

 Click on a blank part of the graphics window to clear the selection and then Define Points at coordinates of **(44,0)** and **(44,7.5)** which form the ends of the radius handle of the fork.

- Select pairs of Points and use the New Line button to create only the straight Lines shown.

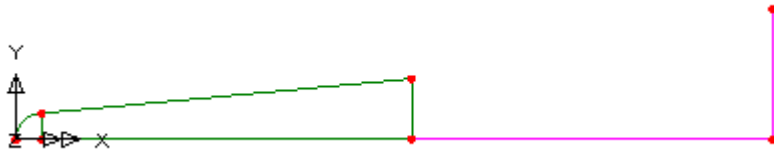

- To define the arc. Select the arc start and end Points, and the Point at the bottom right of the model.

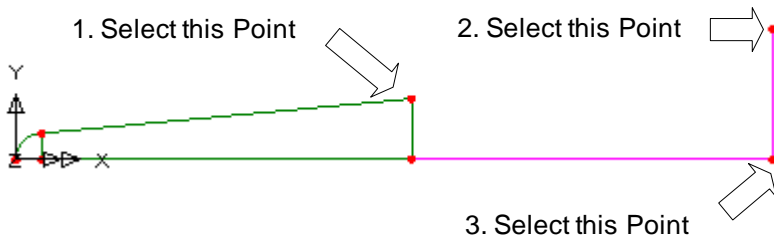

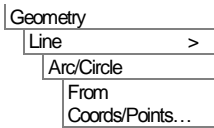

- Specify that coordinate **(44,0)** is a **Direction Point**.
- Ensure that **Minor arc** is selected
- Enter an arc radius of **20**
- Click **OK** to draw the arc.

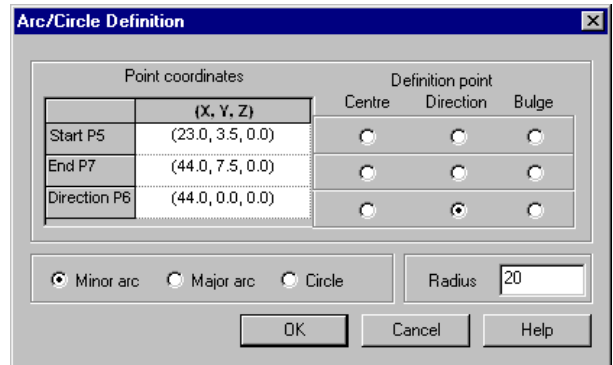

The Lines which mark the extent of the support conditions on the handle (that is the area over which the fork is assumed to be held) will now be defined. This will be done by copying existing Lines.

- Select the first Line shown.

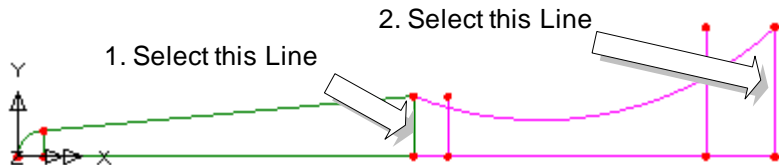

Copy the Line once through a distance of **2** in the **X** direction and click **OK**

- Select the second Line shown



Copy the Line once through a distance of **-4** in the **X** direction and click **OK**

Modal Analysis of a Tuning Fork

Points are now created at the intersections of the arc with the 2 new copied Lines.

1. Select these 3 Lines

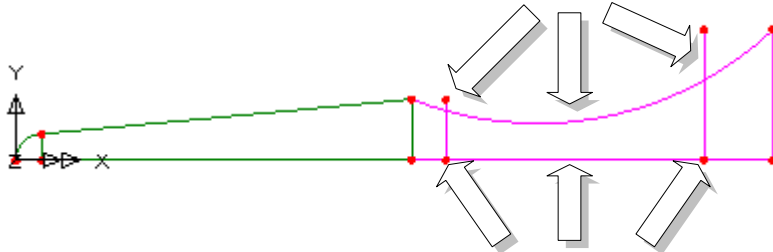

2. Select this Line and these 2 Points

- Select the 3 upper Lines shown using the **Shift** key to add to the initial selection.
- Create **Exact intersections only** and ensure the **Split intersecting lines** and **Delete geometry on splitting** options are selected. Click the **OK** button to create the new Points at the Line intersections and also split the selected Lines.

In order to create 3 separate Surfaces the Line along the axis of symmetry has to be split into 3 new Lines.

- Select the Line and 2 Points shown in the previous diagram.
- Ensure that **Delete features on splitting** is selected and click **OK** to create 3 new Lines.

Three Surfaces are now defined using the Lines previously created.

- Select the 4 Lines (remembering to hold the **Shift** key down after the first line is selected to add to the selection) to form the boundary of the Surface shown.

Select these 4 Lines to create a Surface here also Create a Surface here also

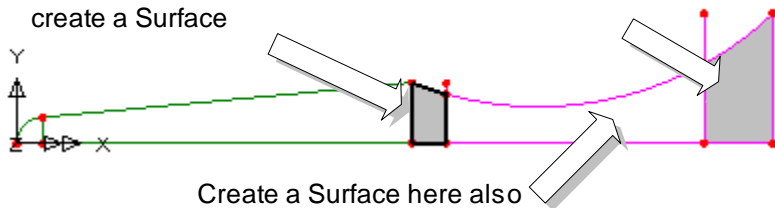

Create a Surface here also





Use the New Surface button to create a Surface.

- Repeat, selecting each set of 4 Lines to define the remaining 2 Surfaces

Lines and Points that are left over from the previous operations can be deleted to tidy-up the model.

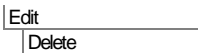
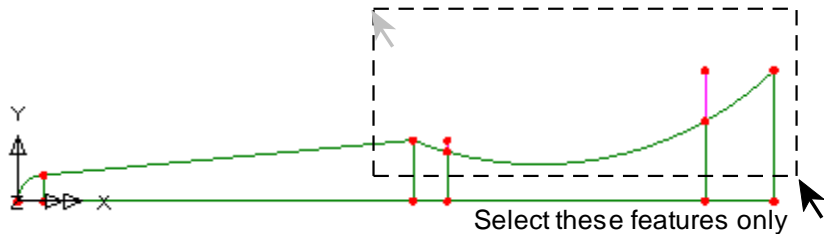
- Drag a box around the features shown, ensuring that no Surfaces are selected.



 To delete the unwanted Lines.

- Select **Yes** to delete Lines.
- Select **Yes** to delete Points.



Note. Only those Point and Line features that are not used to define any Surfaces will be deleted.

- Click on a blank part of the graphics window to clear the selection.

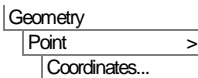

 Enter coordinates of **(48.5,0)** and **(52,7.5)** and click **OK** to define the points.

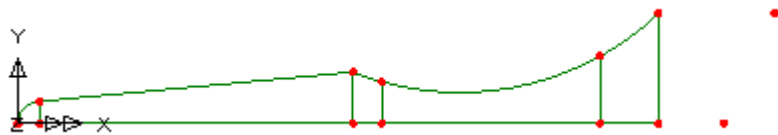

A horizontal Line will now be created.

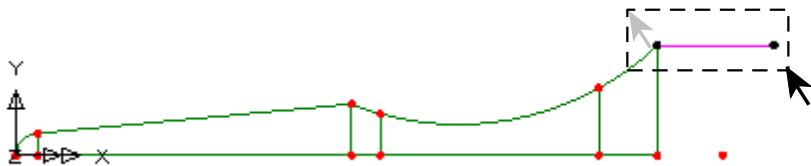

- Select the two Points and create the horizontal straight Line as shown above.

Modal Analysis of a Tuning Fork

Now define the arc at the start of the arm section of the fork.

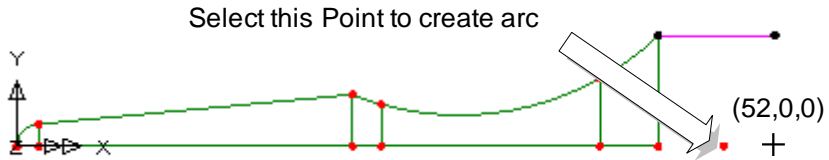

- Select the single Point.



Select the **Rotate** option to sweep the point through an angle of **-90** degrees about the **Z-axis** around an origin Point of **(52, 0, 0)**

- Click **OK** to sweep the Point and create an Arc.

To avoid the creation of a 5-sided Surface at the start of the arm section the arc will be split into two.

- Select the newly created arc.
- Enter **2** for the number of divisions. Ensure **Delete original lines after splitting** is selected and click **OK** to replace the arc with two new arcs.

To complete the junction section of the fork two new Surfaces will be defined.

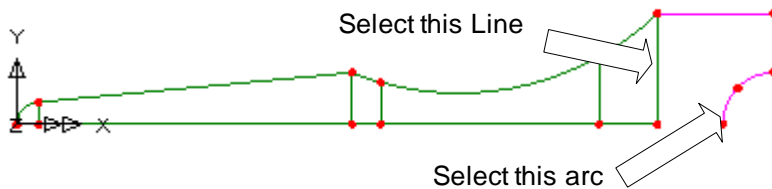

Zoom in to the working area.



Revert to standard cursor mode and select one of the Arcs. Hold down the **Shift** key and select the Line on the opposite side as shown above.



Create the first Surface.

- Repeat the previous procedure to create the second Surface as shown below.

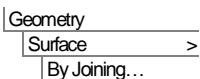
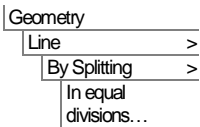
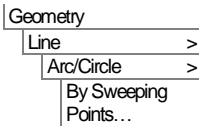



The remainder of the fork will be created by sweeping the vertical Line at the right-hand end of the model through a distance in the X direction.



Resize the model so all features are in view.

- Select the vertical Line shown.

1. Select this vertical Line to create Surface

2. Select this vertical Line to create Surface

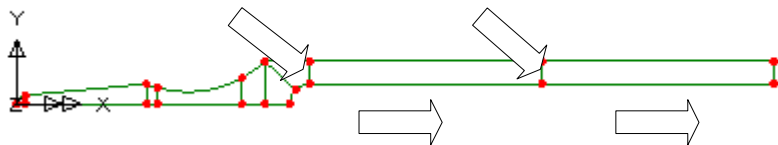

Enter a distance of **41.25** in the **X** direction.

- Click **OK** to create the Surface.
- Select the new Line at the right-hand end of the model.



Use the Sweep Feature button to sweep the Line through a distance of **41.25** in the **X** direction to create the Surface.

The geometry of the half-model of the tuning fork is now complete. Attribute data such as mesh, loading and supports will now be added to the half-model before copying and mirroring to create a full model for analysis.

Meshing

A frequency analysis can use a relatively coarse mesh, since stress output is not required from the analysis. With this in mind, a series of Line meshes will be used to control the density of the Surface mesh.

Line meshes

As the majority of the Lines require only 2 divisions the default number of mesh divisions will be reset.

Geometry
Surface >
By Sweeping...

Geometry
Surface >
By Sweeping...

Modal Analysis of a Tuning Fork

File
Model Properties...

- Select the **Meshing** tab, set the default number of divisions to **2** and click **OK** to return to the graphics window. Any Lines to which a line mesh dataset is not assigned will adopt this as a default.

Selected Lines will be assigned a number of Line divisions. LUSAS provides a limited number of Line Mesh datasets by default. These can be found in the Treeview.

A Line mesh dataset with 12 divisions is not defined by default so one must be created.

Attributes
Mesh >
Line...

- With the Element description set as **None**, define a Line mesh dataset containing **12 divisions** named **Divisions=12**
- Click **OK** to add the dataset name to the Treeview.

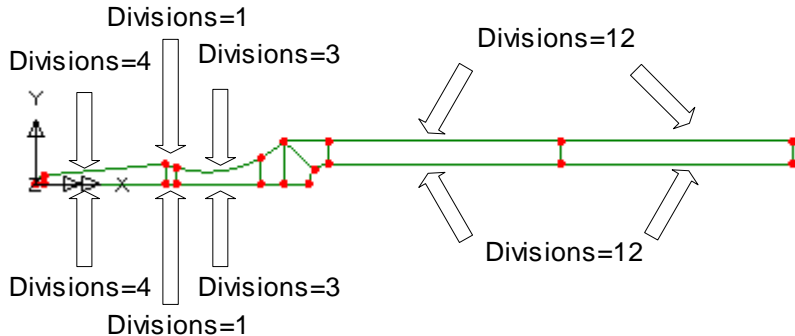

- With the relevant sets of Lines selected, drag and drop the appropriate Line mesh datasets from the Treeview onto the selected features. Use the Zoom in button as necessary.

Surface mesh

Attributes
Mesh >
Surface...

- Define a Surface mesh using **Plane Stress, Quadrilateral, Quadratic** elements. Name the dataset **Plane Stress** and click **OK**
- Using the **Ctrl** and **A** keys together Select the half model of the fork.
- Drag and drop the Surface mesh dataset **Plane Stress** from the Treeview onto the selected features.

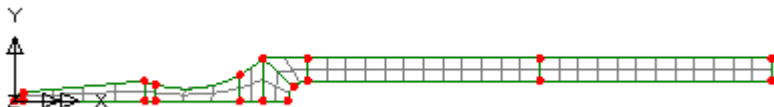





Note. Since all of the Surfaces are 4 (or 3) sided, a regular mesh pattern is created.

At any time the mesh (and other layers) displayed in the graphics window may be hidden or redisplayed. With no features selected click the right-hand mouse button in a blank part of the graphics window and select **Mesh**. If a mesh was previously displayed it will be hidden. If previously hidden it will be displayed. This facility can be used to simplify the display when it is required.

- Remove the **Mesh** from the display as described in the previous note.

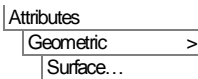
Geometric Properties





- Specify a thickness of **4** and leave the eccentricity blank.
- Enter the dataset name as **Thickness** and click **OK**.
- With the whole model selected (Using the **Ctrl** and **A** keys together) drag and drop the geometry dataset **Thickness** from the  Treeview onto the selected features. Geometric assignments are visualised by default.

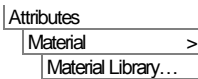

Use the fleshing on/off button to turn off the geometry visualisation.

Material Properties



- Select **Stainless Steel** of grade **Ungraded** and click **OK**
- With the whole model selected, drag and drop the material dataset **Iso1 (Stainless Steel)** from the  Treeview onto the selected features.
- Ensure the **Assign to surfaces** option is selected and click **OK**

Support Conditions

LUSAS provides the more common types of support by default. These can be seen in the  Treeview. To model the holding of the tuning fork the support dataset **Fixed in XY** will be used.



Note. 2D plane stress elements only have X and Y degrees of freedom therefore a restraint in the Z direction is not necessary.

Modal Analysis of a Tuning Fork

- With the arc shown in the diagram selected, drag and drop the support dataset **Fixed in XY** from the  Treeview onto the selected Line.

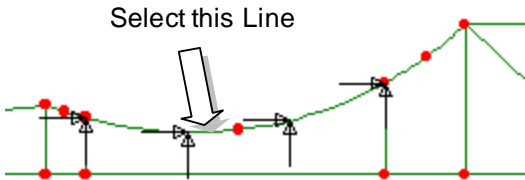

- Ensure the **Assign to lines** and **All loadcases** options are selected and click **OK**
- If supports are not visualised when expected they can be visualised for each support condition by right-clicking on the support name in the supports section of the  Treeview and selecting **Visualise Assignments**.



Note. In practice this support would not be a rigid support since it is hand held but this should not significantly affect the frequencies obtained.

Loading

No loading is required for a natural frequency analysis.



Note. The fork is symmetrical about its centre-line, therefore only half of the structure has so far been created. For static structural analysis it would be common to apply a symmetry support condition to the centreline, so that only half of the structure need be analysed. However, in a frequency analysis the use of symmetry in this way is less common since this will force the analysis to only solve for the symmetric modes of vibration ignoring any anti-symmetric modes. Generally, both symmetric and anti-symmetric vibration modes are of significance, therefore the model will be mirrored to form the complete model.

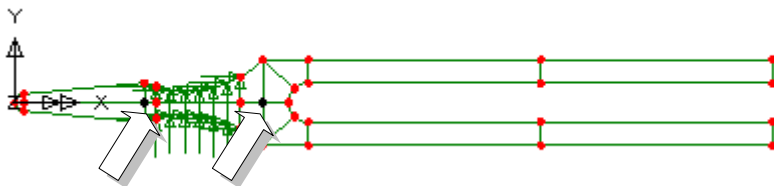

Select these 2 Points to define mirror plane

- Select the 2 Points on the centreline of the tuning fork as shown.

The Points are stored in memory.

- Select the whole model using the **Ctrl** and **A** keys together.

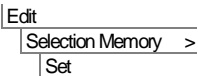

Geometry
Surface
Copy...



Select **Mirror - points 5 7** from the drop-down list and click the **Use** button on the dialog to use the Mirror Points stored in memory.

- Click **OK** to create the full model.

Edit
Selection Memory >
Clear

To remove the Points from the selection memory.



Note. The model is 2 Dimensional, therefore only 2 Points are required to define the mirror plane (the Z direction is assumed as the screen Z plane). In addition, the selection of Points as far away from each other as possible will ensure a good specification of the required mirror plane.

The model is now complete. All attributes assigned to the original half-model features, including the support and mesh assignments, will have been identically reproduced on the duplicated features.

Eigenvalue Analysis Control

The eigenvalue analysis control parameters are applied as properties of the load case.

- In the  Treeview right-click on **Loadcase 1** and select **Eigenvalue** from the **Controls** menu option.

The Eigenvalue dialog will appear.

	Value
Number of eigenvalues	10
Shift to be applied	0

The following parameters need to be specified to perform a frequency analysis with a specified number of the minimum eigenvalues.

- Set the **Number of eigenvalues** required to **10**

Modal Analysis of a Tuning Fork

- Set the **Shift to be applied** to **0**
- Leave the type of eigensolver as **Default**



Note. Eigenvalue normalisation is set to **Mass** by default. This is essential if the eigenvectors are to be used for subsequent IMD analysis in results processing as they are in this case.

- Click the **OK** button to finish.

Saving the model



Save the model file.

File
Save

Running the Analysis

With the model loaded:



A LUSAS data file name of **fork** will be automatically entered in the File name field.

File
LUSAS Datafile...

- Ensure that the options **Solve now** and **Load results** are selected.
- Click the **Save** button to finish.

A LUSAS Datafile will be created from the model information. The LUSAS Solver uses this datafile to perform the analysis.

If the analysis is successful...

LUSAS eigenvalue results will be added to  Treeview.

In addition, 2 files will be created in the directory where the model file resides:



- fork.out** this output file contains details of model data, assigned attributes and selected statistics of the analysis.
- fork.mys** this is the LUSAS results file which is loaded automatically into the  Treeview to allow results processing to take place.

If the analysis fails...

If the analysis fails, information relating to the nature of the error encountered can be written to an output file in addition to the text output window. Any errors listed in the text output window should be corrected in LUSAS Modeller before saving the model and re-running the analysis.

Rebuilding a Model

If it proves impossible for you to correct the errors reported a file is provided to enable you to re-create the model from scratch and run an analysis successfully.



- fork_modelling.vbs** carries out the modelling of the example.

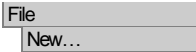

Start a new model file. If an existing model is open Modeller will prompt for unsaved data to be saved before opening the new file.

- Enter the file name as **fork**

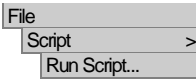

To recreate the model, select the file **fork_modelling.vbs** located in the \<LUSAS Installation Folder>\Examples\Modeller directory.



Rerun the analysis to generate the results

Viewing the Results

This section outlines some typical results processing operations for a natural frequency and Interactive Modal Dynamics (IMD) analysis. The following interactive results processing operations are performed:

- Mode Shape Plots** Displaying mode shapes from the natural frequency analysis.
- Mode Animation Sequence** Animation of selected mode shapes.
- Printing Eigenvalue Results** Printing results to a text window.
- Modal Dynamics (IMD)** Graphing of Displacement vs. Frequency for a selected node (all frequencies) using a linear scale.

Selecting a Results Loadcase

If the analysis was run from within LUSAS Modeller the results will be loaded on top of the current model and the load case results for eigenvalue 1 are set to be active by default.

Plotting Mode Shapes

If present, turn off the **Geometry**, **Attributes** and **Mesh** layers in the  Treeview.

- With no features selected click the right-hand mouse button in a blank part of the Graphics window and select **Deformed mesh** to add the deformed mesh layer to the  Treeview.
- Click the **OK** button and the deformed mesh plot for Eigenvalue 1 will be displayed.

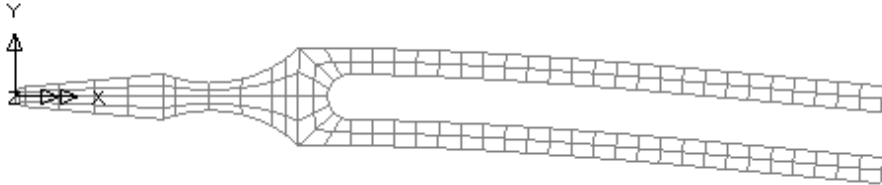

Note. The mode shape may be inverted. This is because the sense is arbitrary since during vibration the deformed shape will appear in both directions.

To view other mode shapes, in the  Treeview right-click on the Eigenvalue required and select the **Set Active** option.

Creating Animations of Mode Shapes

This section will create an animation of the third mode shape.

- In the  Treeview right-click on **Eigenvalue 3** and select the **Set Active** option.
- The deformed shape for Eigenvalue 3 will be displayed.
- Select the **Active loadcase** button and select the **Next** button.
- Use a **Sine** deformation with **8** frames. Set the range to **-1 to 1**. Set the deformation magnitude of **6** mm.
- Click **Finish** and LUSAS will create the animation sequence and display the animation in a new window.

Utilities
Animation Wizard...

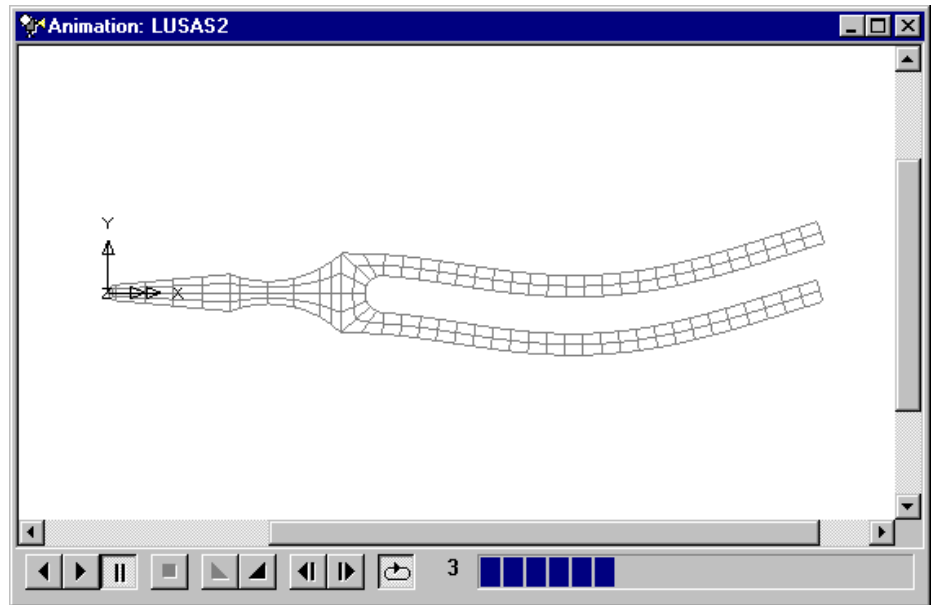

- To see the animation at the best resolution enlarge the window to full size. The buttons at the bottom of the window may be used to slow-down, speed-up, pause, step through frame by frame, or stop the animation.

Saving Animations

Animations may be saved for replay in other Windows applications.

- Ensure the animation window is the active window.
- Enter **fork_mode3** for the animation file name. An **.avi** file extension is automatically appended to the file name when the file is saved.
- Animations can be compressed to save disk space. A number of compression formats are available depending on what is installed on the system. **Microsoft Video 1** has been found to provide reliable results. Click **OK**.



Close the animation window without saving changes.

Printing Eigenvalue Results

Eigenvalue results for the model can be displayed in the Text Output window.

File
Save As AVI...

Utilities
Print Results
Wizard...

Modal Analysis of a Tuning Fork

- Select Entity **None** of results Type **Eigenvalues** and click the **Finish** button to print the eigenvalues to the text output window. Your values should be similar to these:

```
Results File = C:\Lusas140\Projects\fork.mys ID=0
Eigenvalues
```

MODE	EIGENVALUE	FREQUENCY	ERROR NORM
1	0.725647E+07	428.729	0.137567E-08
2	0.740305E+07	433.037	0.136178E-08
3	0.272988E+09	2629.61	0.461326E-10
4	0.283643E+09	2680.44	0.430260E-10
5	0.200119E+10	7119.74	0.392818E-10
6	0.214224E+10	7366.38	0.127963E-10
7	0.375775E+10	9756.28	0.252194E-10
8	0.572457E+10	12041.8	0.139476E-10
9	0.668763E+10	13015.4	0.258395E-09
10	0.810989E+10	14332.7	0.956746E-07



Note. The error norms may vary as they are dependent on the Eigensolver used for the solution.



Close the text window.

Interactive Modal Dynamics

The vertical displacement response of a selected node for a unit vertical force is to be plotted against the sampling frequency over the entire solved frequency range (0-15000 Hz) on a linear scale.

- Select the node at the end of the arm shown.

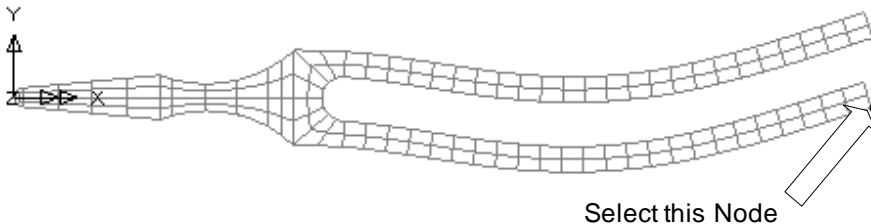

Using the Graph Wizard

The graph wizard provides a step-by-step means of selecting results to be plotted on the X and Y axes of a graph. The X axis data is always defined first.

Utilities

Graph Wizard...

- Select the **Modal Expansion** option and click the **Next** button.
- The **Frequency** response for **All** modes is to be calculated for the X axis data. Ensure the Damping Type is set to **None**
- On the Modal Excitation section of the dialog ensure that **Point** excitation is selected and click the adjacent **Set** button.
- Select the **Node number** previously selected from the drop-down list. Select component **DY** and click the **OK** button to return to the main dialog.
- Click the **Next** button.

The excitation loading has been defined. The response has now to be defined.

- On the Modal Frequency Domain dialog select **Displacement** results of component **DY**. Enter **Sampling frequency** values of **Start** as **0**, **End** as **15000** and **Step** as **100**
- Click the **Next** button.

The response has now been defined. Frequency (X) and Amplitude (Y) axis datasets are now generated to graph the displacement frequency response at the selected node.

Additional information for the graph can now be added.

- Leave all graph title information blank.
- De-select the **Show symbols** button.
- Click the **Finish** button to end.



Note. If no graph or axis titles are entered default names will be used. The graph attributes may be edited by right clicking on the graph and selecting **Edit Graph Properties**

Modal Analysis of a Tuning Fork

LUSAS will create the graph in a new window and display the values used in an adjacent table. To see the graph at the best resolution enlarge the window to a full size view.

- Position the cursor over the first peak on the graph to see the values at the peak of X=400 (Frequency) and Y=0.371 (Amplitude DY)

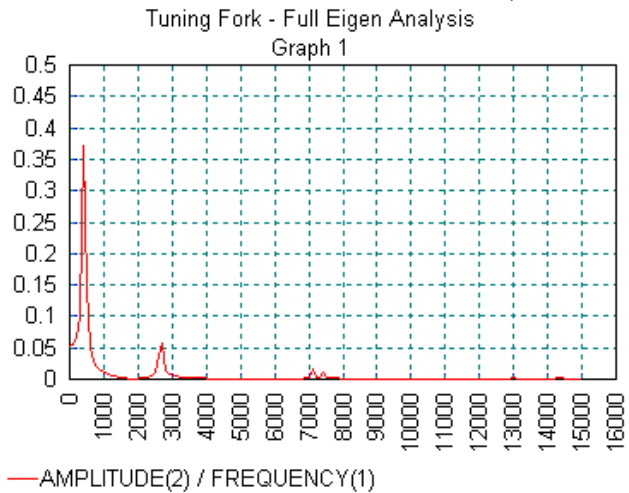

Note. So it is seen that

by using a large frequency range with a 100Hz interval the peak amplitude the actual mode 1 frequency of 428.729Hz can be missed when plotting graphs of this nature. Because of this, it is better to use a smaller frequency range in order to isolate the peak results.

To produce a more detailed graph

- Close the current graph window.
- Ensure the same node is selected on the fork.
- With the **Modal Expansion** option selected click the **Next** button.
- With all options that were set previously selected click the **Next** button.
- Select **Displacement** results of component **DY**. Enter sampling frequency values of **Start** as **0**, **End** as **800** and **Step** as **1**
- Click the **Next** button.
- Leave all graph title information blank.
- Ensure the **Show symbols** option is not selected
- Click the **Finish** button to end.

Utilities
Graph Wizard...

LUSAS will create a graph in a new window and display the values used in an adjacent table. To see the graph at the best resolution enlarge the window to a full size view.

- Position the cursor over the main peak on the graph to see the values at the peak of $X=433$ (Frequency) and $Y=145.89$ (Amplitude DY). This is a theoretical amplitude and is related to no damping being present.

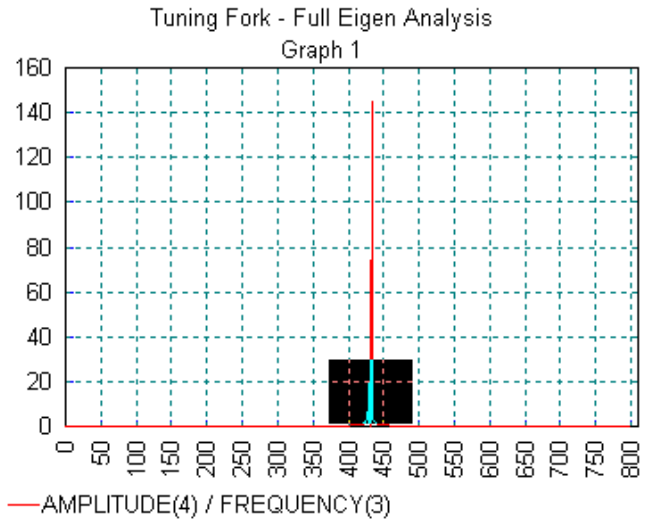

- Click and drag the cursor over the region shown on the previous graph and a new graph the peak for the first mode shape will be seen

This displays a better representation of the displacement/ frequency response in the vicinity of the first two mode shapes.

- Position the cursor over the first peak on the graph to see the values at the peak of $X=429$ (Frequency) and $Y=18.89$ (Amplitude DY)

These values compare more favourably with those obtained from using the Print Results Wizard for mode 1 earlier in the example.

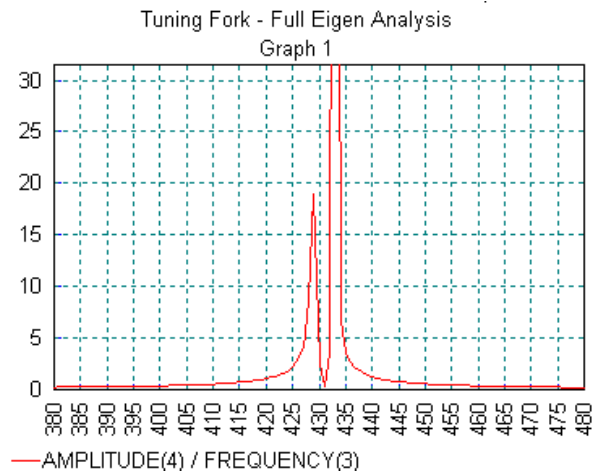

- Right-click and select **Unzoom** to return to the previous graph view.

Plotting Dynamic Response for a Particular Frequency

In some analyses, dynamic responses are required at a specified frequency. In these cases, an Interactive Modal Dynamics (IMD) load case is defined to allow the frequency and type of excitation to be specified. In this example, deformed shapes and peak displacements are to be plotted for excitation frequencies of 750Hz and 1500Hz.

 Close all graph windows to leave the model window active. Ensure the node at the end of the fork is still selected.

On the IMD Loadcase properties dialog:

- Select **Point** excitation and click the adjacent **Set** button.
- Select the **Node number** previously selected from the drop-down list. Select component **DY** and click the **OK** button to return to the IMD Loadcase main dialog.
- Select **Frequency** results and click the adjacent **Set** button.
- Enter a **Frequency** of **750**
- Click the **OK** button to return to the main dialog.
- Ensure the name is set to be **IMD 1**
- Click the **OK** button to finish defining the IMD loadcase.

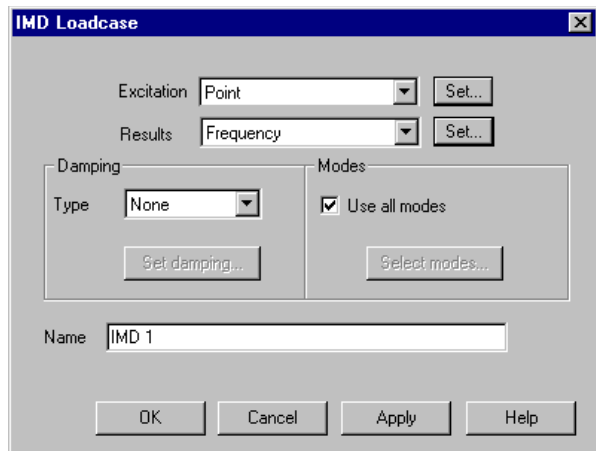

Selecting the IMD Results Loadcase

- In the  Treeview right-click on **IMD 1** and select the **Set Active** option.



The deformed mesh plot is updated to show the deformed mesh at the specified frequency.

Marking Peak Values

- With no features selected click the right-hand mouse button in a blank part of the Graphics window and select the **Values** option to add the **Values** layer to the  Treeview.
- The values properties will be displayed.
- Select **Displacement** results of displacement in the Y direction **DY**. Select the **Values Display** tab and select the top 0% of **Maxima** values.
- Click the **OK** button to display the top value of displacement for this IMD results loadcase frequency.

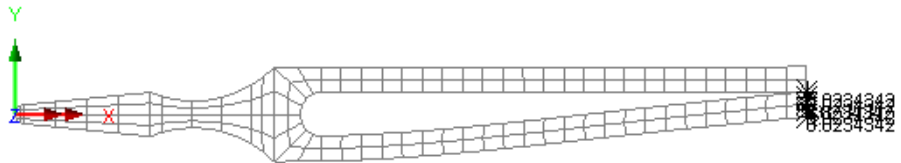

Changing the results frequency

- In the  Treeview double-click the **IMD 1** dataset name.
- Click the **Set** button adjacent to the **Frequency** option.
- Change the frequency to **1500** and click the **OK** button to return to the main dialog.
- Click the **OK** button to finish defining the IMD loadcase.

The deformed mesh plot will be updated to show the revised mode shape and corresponding values for the specified frequency.

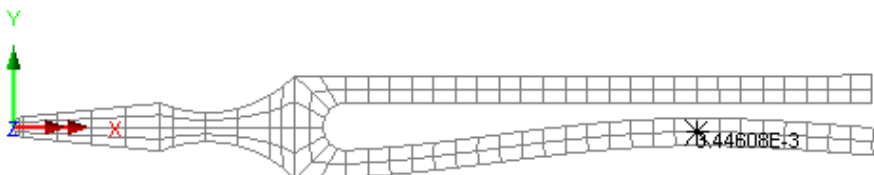

Modal Analysis of a Tuning Fork



Note. Since the eigenvalue is independent of sign the deformed shape may appear inverted from that shown.

This completes the example.

Modal Response of a Sensor Casing

For software product(s):	All (except LT versions)
With product option(s):	Plus

Description

An aerospace sensor casing is to be assessed for dynamic stresses induced by vibration of the airframe to which it is attached.

The sensor casing is manufactured from steel plate with a uniform thickness of 0.8 mm.

The surfaces at the top of the sleeve are rigidly held. The loading is characterised by a random vibration at the supports of the airframe and is defined as an acceleration Power Spectral Density (PSD) specified by the airframe manufacturer.

The Interactive Modal Dynamics (IMD) facility is used to evaluate the response of the casing to this loading. A quarter model is initially defined with the sleeve modelled as if it were in the centre of the casing, and subsequently copied to create the full model. The sleeve is then repositioned to the location shown to show the associativity of features.

Units of N, m, kg, s, C are used for the analysis.

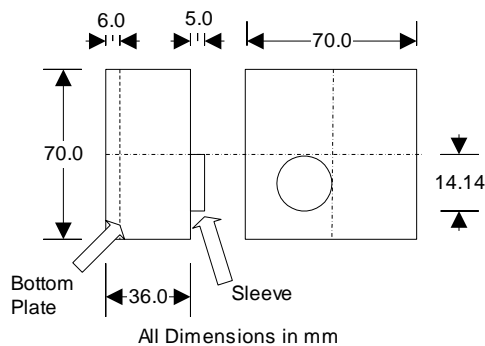

Objectives

The following results plots are to be obtained:

- Deformed Shape** A display of the deformed mesh for the first mode shape.
- Frequency Response Function** FRF of a node using support motion excitation.
- Power Spectral Density** PSD stress response at a node using a PSD excitation function.

Keywords

Linear, Eigenvalue, Scale Factor Transformation, Interactive Modal Dynamics (IMD), Default Attribute Assignment, Deformed Shape, Frequency Response Function (FRF), Power Spectral Density (PSD), Stress Contours.

Associated Files

If results processing and not the actual modelling of an example is only of interest to you the VBS file(s) provided will allow you to quickly build a model for analysis. For more details refer to Creating a Model From The Supplied VBS files in the Introduction.



- casing_modelling.vbs** carries out the modelling of the example.

Modelling

Running LUSAS Modeller

For details of how to run LUSAS Modeller see the heading *Running LUSAS Modeller* in the Examples Manual Introduction.



Note. This example is written assuming a new LUSAS Modeller session has been started. If continuing from an existing Modeller session select the menu command **File>New** to start a new model file. Modeller will prompt for any unsaved data and display the New Model dialog.

Creating a new model

- Enter the file name as **casing**

- Use the **Default** working folder.
- Enter the title as **Modal Response of Sensor Casing**
- Set the units as **N,m,kg,s,C**
- Ensure the **Structural** user interface is selected
- Select the model template **Standard**
- Select the **Vertical Y axis**.
- Click the **OK** button.







Note. Save the model regularly as the example progresses. Use the Undo button to correct any mistakes made since the last save was done.

Default assignments

The material properties, plate thickness and mesh element type are uniform over the whole sensor casing. By using default attribute assignments, attribute datasets are automatically added to new features when they are created.

Automatic Mesh Assignment

- Define a Surface mesh using **Thin shell**, **Quadrilateral** elements with **Linear** interpolation.
- Enter **Thin shell** for the mesh dataset name.
- Click the **OK** button to add the mesh dataset to the  Treeview.
- To set this mesh dataset as the default surface mesh assignment click the right-hand mouse button on the **Thin shell** dataset name in the  Treeview and select the **Set Default** option. The  icon will change to  indicating that **Thin shell** will automatically be assigned to all new Surfaces.

Automatic Geometry Assignment

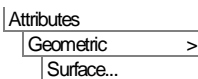
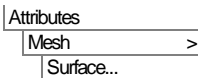

- Enter a Surface element thickness of **0.0008**
- The eccentricity can be left blank or set to zero as it is not required.
- Enter the dataset name as **Thickness of 0.0008** and click **OK** to add the dataset to the  Treeview.



Modal Response of a Sensor Casing

- To set this geometry dataset as the default geometry assignment click the right-hand mouse button on the **Thickness of 0.0008** dataset name in the  Treeview and select the **Set Default** option.

Automatic Material Assignment

- The sensor is made from steel so select **Mild Steel** from the drop down list.
- Click **OK** to add the material to the  Treeview.
- Set this material as the default material assignment by clicking the right-hand mouse button on the **ISO 1(Mild Steel Ungraded)** material dataset in the  Treeview and selecting the **Set Default** option.

Feature Geometry

In a natural frequency analysis, consistent units such (N, m, kg, sec) must be used. It is however more convenient to define the geometry in millimetres and scale the model when the geometry input is complete.

Defining the sleeve of the sensor



Note. The sleeve is defined initially as if it were positioned centrally on the casing. Later in the example it will be moved to its actual position to show the associativity of features.

 Define a Line on the sleeve from **(0,0)** to **(-5,-5)** and click the **OK** button.

- Select the Line just drawn.

 Sweep the line into a surface by choosing the **Rotate** option and entering an angle of **90** degrees to rotate the line about the **Z-axis** about an origin of **0,0,0**

- Click the **OK** button to complete the Sweep operation.

 Select the fleshing on/off button to turn-off geometric property visualisation.

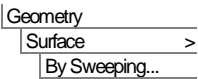
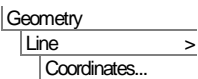
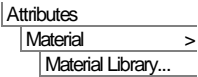
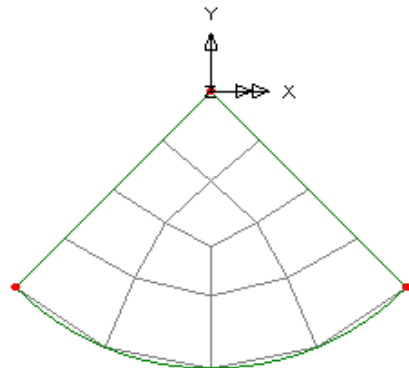

The number of elements modelling the end of the sleeve will be reduced.

- Select the two radial Lines and adjust the mesh by assigning Line mesh **Division=1** from the  Treeview.

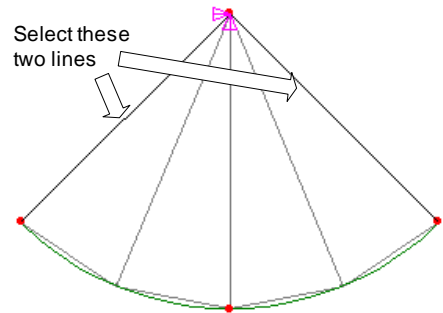



Defining the mesh for the sleeve

The arc will now be swept to create a Surface.

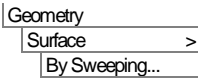
- Select the arc



-  Sweep the arc into a surface by selecting the **Translate** option and enter a translation of **-5** in the **Z** direction. Click the **OK** button to create the surface.

-  Use the Isometric view button to view the Surface created.

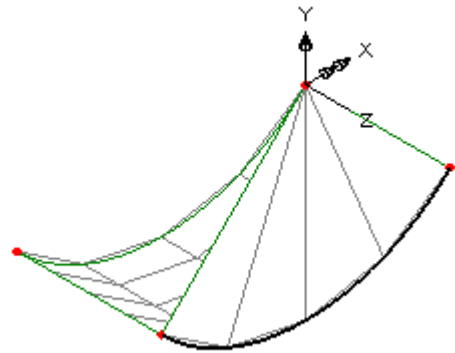

The sides of the sensor will now be defined.



Note. To simplify the modelling the sleeve will be defined at the centre of the plate and moved when the full model has been generated.

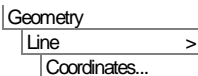

-  Enter coordinates of **(-35, -35, -5)** and **(35, -35, -5)** to define a Line representing the bottom edge of the housing. Click **OK** to generate the Line.

A new Surface can be created by joining this new Line to the previously defined arc to form a quarter of the housing plate.

- Select the arc shown right and add the Line at the bottom edge of the sensor to the selection by hold down the **Shift** key.

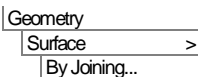

-  A Surface will be created.

Modal Response of a Sensor Casing

The Line at the bottom edge of the sensor casing is now to be swept to create the bottom Surface of the casing.

- Select the bottom edge Line of the housing.



Choose the **Translate** option and define a translation of **-30** in the **Z** direction. Click the **OK** button to create the new Surface.

Geometry
Surface >
By Sweeping...

1. Select this arc

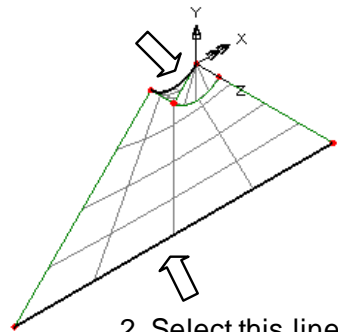

To define the portion of casing beyond the bottom plate, select the Line shown.



Define a translation of **-6** in the **Z** direction and click **OK** to sweep a new Surface.

Geometry
Surface >
By Sweeping...

Sweep this line through -6 units in the Z direction

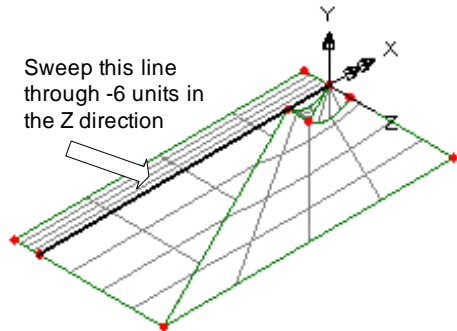

- Now adjust the mesh on the new surface by selecting the 2 Lines of the casing indicated in the diagram and drag and drop the Line mesh **Divisions=1** from the  Treeview onto the selected features.

Select these 2 lines and assign Line Mesh Divisions=1

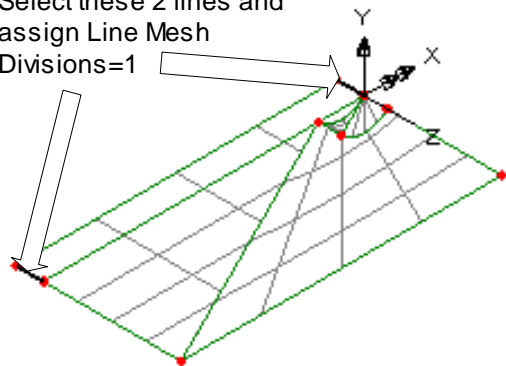

This completes the definition of the features of the quarter model.

Supports



Note. Supports are to be assigned to the quarter model before copying is done to save time assigning the support dataset to the equivalent copied Surfaces.

- Select the Surface at the end of the sleeve. If necessary, zoom in and cycle through the displayed features by clicking the left-hand mouse button until the Surface required is highlighted.

Selected: Surface 1 (4 items cyclable)

- Drag and drop the support dataset **Pinned** from the  Treeview onto the selected surface and click **OK**

The full housing model can now be created from the quarter model

- Using the **Ctrl** and **A** keys together, select the whole model.



Use the copy button to **Rotate** the selected features through **90** degrees about the **Z-axis** and create **3** copies of the original selection.

- Click **OK** and Modeller will create and display the extra features.
- To generate the bottom plate select the 4 Lines shown.



The Surface defining the bottom plate will be created.

Finally the sleeve must be moved off centre.

Z: N/A

Rotate the model to view along the Z axis by clicking in the status bar at the bottom of the Modeller window.

- For clarity delete the **Mesh** and **Attributes** layers from the  Treeview.

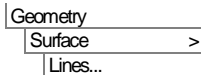
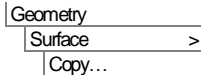
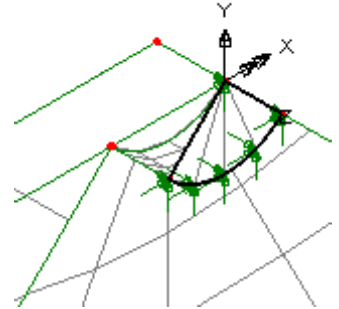

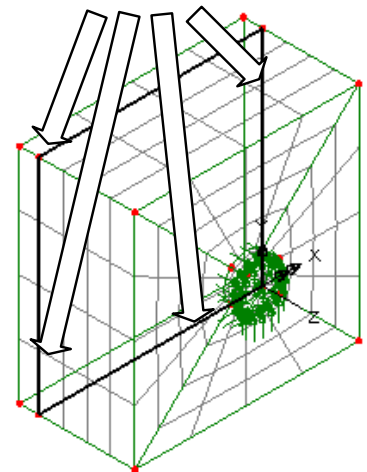

Select these 4 lines

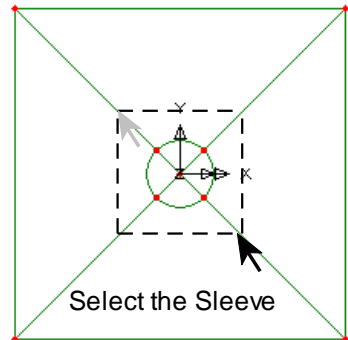

Modal Response of a Sensor Casing

- Box select the features which make up the sleeve.



-  Move the sleeve to the required position by entering a translation of **-7.07** in the X direction and **-7.07** in the Y direction and click **OK**

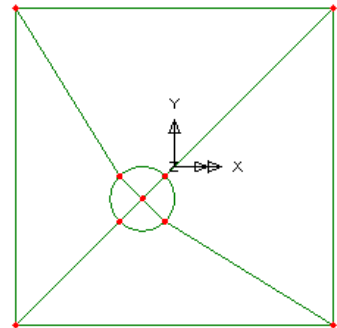

Finally the geometry must be scaled so the units are metres.

- Use the **Control** and **A** keys together to select the full model.

-  Select the **Scale** option and enter a scale factor of **0.001** about an origin of 0,0,0.

- Click **OK** to scale the geometry from millimetres to metres.

Eigenvalue Analysis Control

To carry out results processing using the Interactive Modal Dynamics facility, an eigenvalue analysis must be performed. The results from the eigenvalue analysis normalised to global mass will be used to perform the Frequency Response Function calculations.

The eigenvalue analysis control properties are applied as a function of the load case.

- In the  Treeview right-click on **Loadcase 1** and select **Eigenvalue** from the **Controls** menu option.

The Eigenvalue dialog will appear.

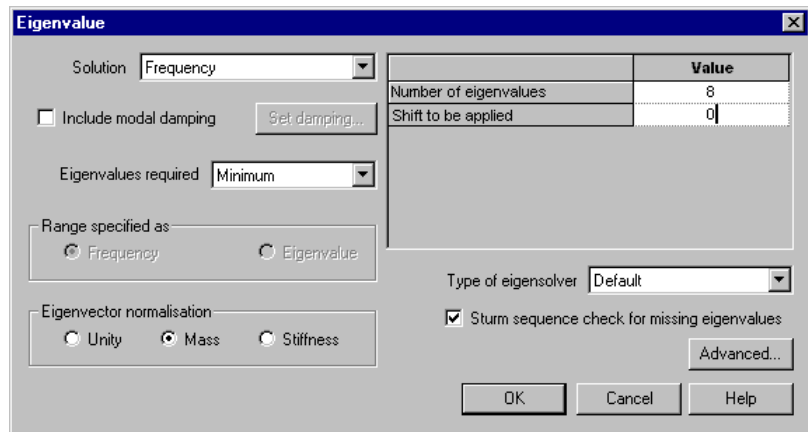

The following parameters need to be specified to perform a frequency analysis with the minimum number of eigenvalues.

- Set the **Number of eigenvalues** required as **8**
- Set the **Shift to be applied** as **0**
- Leave the type of eigensolver as **Default**



Note. Eigenvalue normalisation is set to **Mass** by default. This is essential if the eigenvectors are to be used for subsequent IMD analysis in results processing as in this case.

- Click the **OK** button to finish.

Saving the model

The model is now complete.



Save the model file.

Running the Analysis

With the model loaded:



A LUSAS data file name of **casimg** will be automatically entered in the File name field.

- Ensure that the options **Solve now** and **Load results** are selected.

Modal Response of a Sensor Casing

- Click the **Save** button to finish.

A LUSAS Datafile will be created from the model information. The LUSAS Solver uses this datafile to perform the analysis.

If the analysis is successful...

The LUSAS results will be added to the  Treeview.

In addition, 2 files will be created in the directory where the model file resides:



- casing.out** this output file contains details of model data, assigned attributes and selected statistics of the analysis.
- casing.mys** this is the LUSAS results file which is loaded automatically into the Treeview to allow results processing to take place.

If the analysis fails...

If the analysis fails, information relating to the nature of the error encountered can be written to an output file in addition to the text output window. Any errors listed in the text output window should be corrected in LUSAS Modeller before saving the model and re-running the analysis.

Rebuilding a Model

If it proves impossible for you to correct the errors reported a file is provided to enable you to re-create the model from scratch and run an analysis successfully.



- casing_modelling.vbs** carries out the modelling of the example.



Start a new model file. If an existing model is open Modeller will prompt for unsaved data to be saved before opening the new file.

- Enter the file name as **casing** and click **OK**

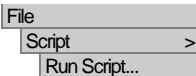

To recreate the model, select the file **casing_modelling.vbs** located in the **\<LUSAS Installation Folder>\Examples\Modeller** directory.



Rerun the analysis to generate the results

Viewing the Results



This section outlines some typical results processing operations for a natural frequency and Interactive Modal Dynamics (IMD) analysis. The following interactive results processing operations are performed:

- Mode Shape Plots** Displaying mode shapes from the natural frequency analysis.
- Frequency Response Function (IMD)** Graphing of Acceleration due to support motion vs. Frequency for a selected node (all frequencies) using a linear scale.
- Power Spectral Density Response (IMD)** Displaying the PSD stress response for a node on the top plate due to a PSD acceleration input at the supports.

Selecting a Results Loadcase

If the analysis was run from within Modeller the results will be loaded on top of the current model and the loadcase results for each eigenvalue can be seen in the  Treeview.

Displaying the 1st Mode Shape

- Turn off all layers in the  Treeview.
- Ensure **Eigenvalue 1** is set active in the  Treeview.
- With no features selected click the right-hand mouse button in a blank part of the graphics window and select **Deformed mesh** to add the deformed mesh layer to the  Treeview.
- Change the specified magnitude to **20** and click the **OK** button to display the deformed mesh for eigen mode 1.

Modal Response of a Sensor Casing



Use the Dynamic Rotation button to rotate the model to a similar view to that shown.



Return to normal cursor mode.





Note. For more complex mode shapes it may be beneficial to animate the mode shape so it can be seen in more detail.

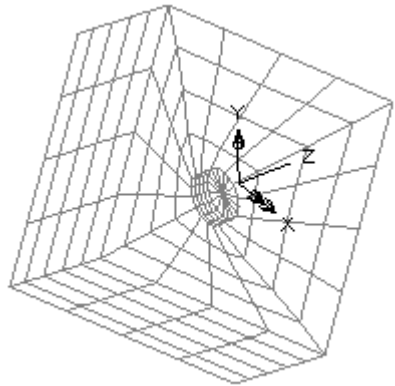

Note. In some cases the mode shape may appear inverted. This is because the Eigenmode represents the shape of the vibrating body and the displacements may be multiplied by -1.



Stresses as Filled Contours

- Turn off the **Deformed mesh** layer in the  Treeview
- With no features selected click the right-hand mouse button in a blank part of the graphics window and select **Mesh** to add the mesh layer to the  Treeview and click **OK** to accept the default properties.
- Transform the view to visualise the model from the X direction by clicking on the in the status bar at the bottom of the Modeller window.
- Select an area enclosing the top plate of the housing as shown.



Create a new group consisting of the elements forming the top plate.

- Enter **Top Plate** as the group name and click **OK**.



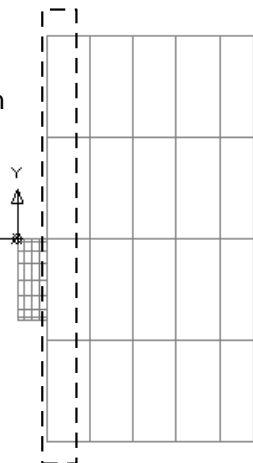

Rotate the model to view along the Z axis by clicking in the status bar at the bottom of the Modeller window.

Select elements on top plate by boxing region shown.



- Make the top plate the only visible part of the model by clicking with the right-hand mouse button on **Top Plate** in the  Treeview and selecting **Set as Only Visible**

- Ensure the results for **Eigenvalue 1** are set active in the  Treeview.
- With no features selected right-click on a blank part of the screen and select **Contours**
- Select the **Stress (top) – Thin Shell** entity and maximum absolute stress component **Sabs**
- Click the **OK** button to display contours of maximum absolute stress.
- To display the mesh on top of the contours select **Mesh** in the  Treeview and drag and drop it on top of the **Contours** layer name.

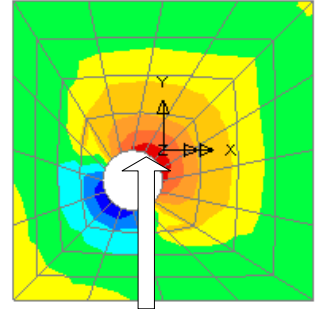

Highest stressed node.

The node where the maximum absolute stress occurs is noted at the bottom of the contour key.

- **Make a note of this node number as it will be used later in the example.**





Note. The contours are relative stress contours which have no quantitative meaning.

Interactive Modal Dynamics



Note. A FRF (frequency response function) is a transfer function in the frequency domain. In general terms, the transfer function indicates how much of the input excitation is transferred to the selected output point.

Compute the modal acceleration response in the Z direction at the node in the centre of the bottom surface due to a harmonically varying acceleration applied to the structural supports.

- Delete the **Contours** layer from the  Treeview.
- Redisplay the full model by selecting the **casimg.mdl** in the  Treeview with the right-hand mouse button and selecting **Set as Only Visible**. Select **Yes** to act on sub-group as well.

Modal Response of a Sensor Casing



Rotate the model as shown



Return to normal cursor mode.

- Select the node at the centre of the bottom plate.

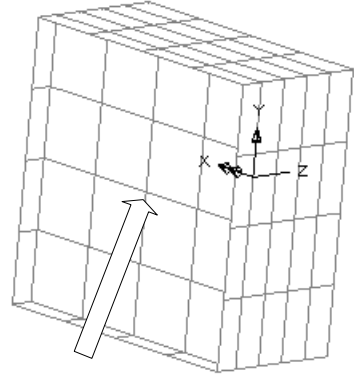

Select this node at centre of back plate

- Select the **Modal Expansion** option and click the **Next** button.
- On the Modal Dynamics Graph dialog choose the **Frequency** entity.
- Under the damping section choose **Specified values** from the drop down list.

Utilities

Graph Wizard...

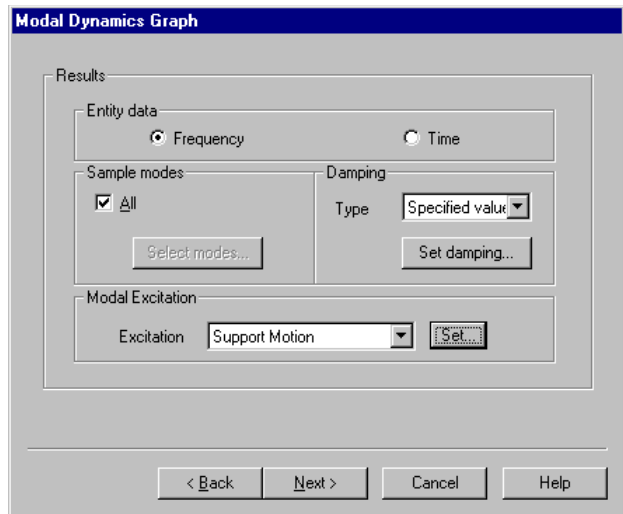

- Select the **Set damping** button and set the viscous damping to **0** and the structural damping to **2.8**
- Click the **OK** button to return to the Modal Dynamic Graph dialog.



Note. If damping values are specified for the first mode only, the other modes will take the same values.

	Viscous (%)	Structural (%)
1	0	2.8

- From the Modal Excitation drop down list select **Support Motion**
- Click on the **Set** button and on the Support Motion dialog specify **Acceleration** in the **Z** direction.
- Click the **OK** button to return to the Model Dynamics Graph dialog and click **Next**

- On the **Modal Frequency Domain** dialog select the **Displacement** entity in the **DZ** direction.
- Set the calculated entity as **Acceleration** of Type **Amplitude**. The selected node number at the centre of the back plate will be displayed in the drop down node list.
- Set the sampling frequencies start, end and step entries to **50**, **3000** and **5** respectively.

Modal Response of a Sensor Casing

- Click **Next**
- On the **Display Graph** dialog ensure that the **Show symbols** option is not selected.
- In the Y Scale section select the **Use logarithmic scale** option.
- Click on the **Finish** button and a graph of log acceleration against frequency will be plotted.
- To specify axis labels and title right click on the graph and select **Edit graph properties**
- On the **General** tab set the graph title to **FRF in Z Direction at Centre of Back Plate (2.8% Structural Damping)**
- Click on the **X Axis Style** tab and set the axis name to **Frequency (Hz)**
- Click on the **Y Axis Style** tab and axis name to **Log Acceleration (m/s²)**
- Click **OK** to update the graph display.

FRF in Z Direction at Centre of Back Plate (2.8% Structural Damping)

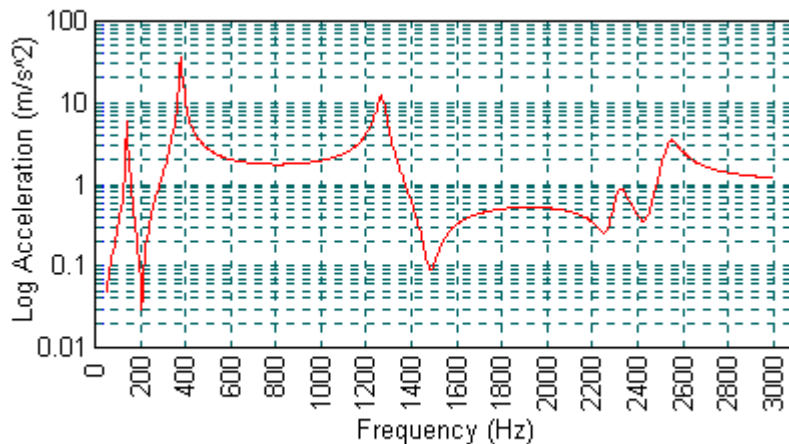

AMPLITUDE / FREQUENCY —



Delete the graph window

Power Spectral Density definition

A PSD force input defines the frequency content of a random loading, such as turbulent pressure acting on an aircraft component. A PSD analysis is, therefore, useful when broadband random dynamic forces excite structural vibrations.

Graph of PSD Stress Response

- Click the left-hand mouse button in a blank part of the graphics window to clear the current selection.
- Click the right-hand mouse button in a blank part of the graphics window and select the **Advanced Selection** option.
- With the **Type and name** option selected, choose **Node** from the drop down list and **enter the node number** at which the maximum principal stress occurs (as noted down at an earlier stage in this example).
- Click **OK** to add the node to the selection.
- To compute a PSD stress response select the **Modal expansion** option and click **Next**
- On the Modal Dynamics Graph dialog choose the **Frequency** entity.
- Under the damping section choose **Specified values** from the drop down list. Select the **Set damping** button and set the viscous damping to **0** and the structural damping to **2.8** and click **OK**
- From the Excitation drop down list select **Support Motion**
- Click on the **Set** button and under support motion specify **Acceleration** in the **Z** direction and click the **OK** button to return to the Model Dynamics Graph dialog.
- Click **Next** to move to the next dialog.
- On the Modal Frequency Domain dialog select entity **Stress (top) – Thin Shell** with component **S1**
- Set the start, end and step sampling frequencies to **50**, **3000** and **5** respectively.



Note. The sampling frequency range must lie within the frequency range of the PSD dataset defined

Utilities
Graph Wizard...

earlier.

- Select **PSD Response** from the Type drop down list and click the **PSD set** button.
- On the RMS response for Power Spectral density dialog ensure the **Linear/Linear** scale option is selected and define a frequency PSD dataset using the frequency and amplitude values shown in the table on the right (Use the **Tab** key to create a new line in the table).
- Label the dataset **Frequency PSD** and click **OK**
- The selected node number will be displayed in the drop down node list.
- Click the **Next** button.
- On the **Display Graph** dialog deselect the **Show grid** option. Deselect the **Show symbols** option and select the **Use Logarithmic scale** option for the Y Scale.
- Click the **Finish** button to plot a graph of log PSD against frequency.

Linear Frequency	Linear Amplitude
15	8
100	14
125	30
500	31
600	61
900	108
1000	79
3000	47

The RMS value of the input PSD and response PSD are written to the message window when the graph is plotted.

Top Surface Maximum Principal Stress (2.8% Structural Damping)

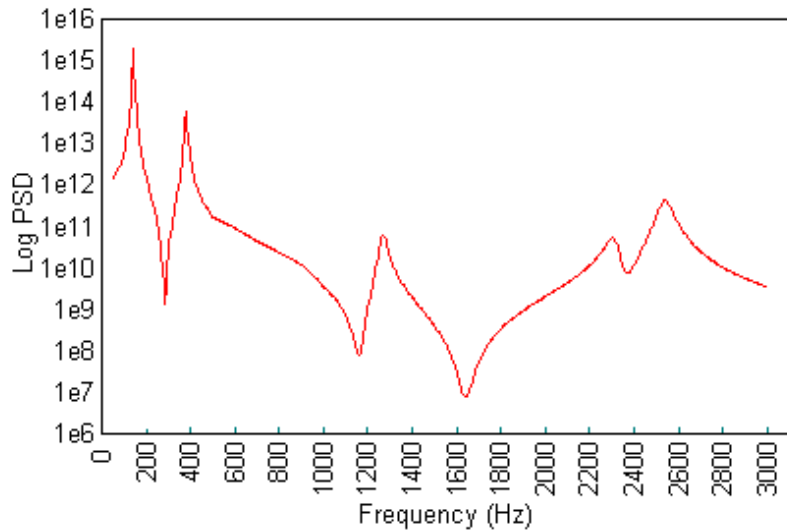

PSD_RESP / FREQUENCY (3) —

- To specify axis labels and title right-click on the graph and select **Edit graph properties**
- On the **General** tab set the graph title to **Top Surface Maximum Principal Stress (2.8% Structural Damping)**
- Click on the **X Axis Style** tab and set the axis name to **Frequency (Hz)**
- Click on the **Y Axis Style** tab and axis name to **Log PSD**
- Click **OK** to update the graph.
- Do not delete the graph. It will be also used to plot the PSD input values.

PSD Input

The PSD input data used in the acceleration of the supports can be plotted on the same graph by following the above procedure until the Modal Frequency Domain dialog is reached.

Modal Response of a Sensor Casing

- With the node at which maximum principal stress occurs still selected, follow the steps in creating the PSD Response graph starting with the Utilities > Graph Wizard menu option but, when the Model Frequency Domain dialog is displayed, instead of selecting PSD Response select **PSD Input** in the **Type** drop down list.
- When the Display Graph dialog is reached, select the option to **Add to existing graph** and ensure that the **Show symbols** is not selected

Top Surface Maximum Principal Stress (2.8% Structural Damping)

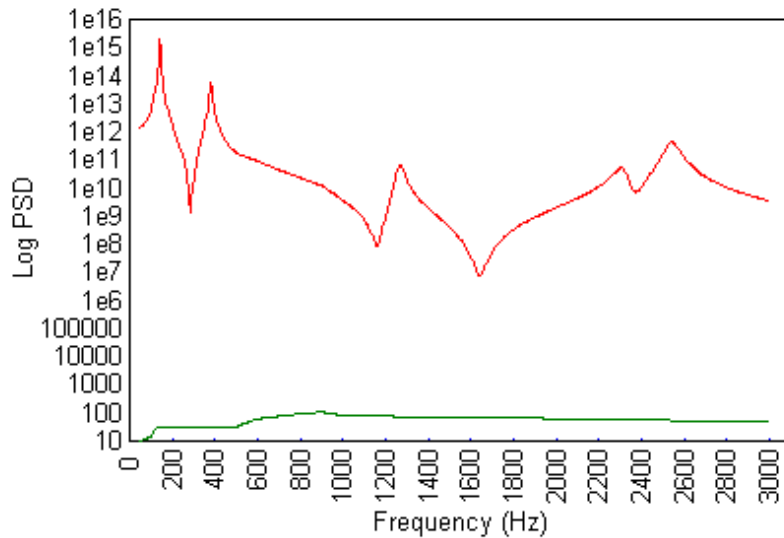

PSD_RESP / FREQUENCY(3) —

PSD_INPUT / FREQUENCY(5) —

- Click **Finish** to update the graph.

This completes the example

Thermal Analysis of a Pipe

For software product(s):	Any Plus version
With product option(s):	Thermal, Dynamics (for the second stage of the example)

Description

This example provides an introduction to performing a thermal analysis with LUSAS.

A continuous steel pipe is exposed to an atmospheric temperature of 25°C. Oil at 150°C is to be pumped through the pipe. The pipe has a thermal conductivity of $60 \text{ J s}^{-1} \text{ m}^{-1} \text{ }^\circ\text{C}^{-1}$, a specific heat capacity of $482 \text{ J kg}^{-1} \text{ }^\circ\text{C}^{-1}$ and a density of 7800 kg/m^3 . Two analyses will be carried out. A steady state analysis is required to determine the maximum temperature of the outer surface of the pipe and a transient thermal analysis is then performed to find out the time it will take the surface to reach this temperature once pumping begins.

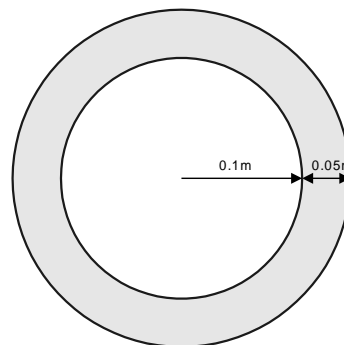

The units of the analysis are N, m, kg, s, C throughout.



Note. There are three transport mechanisms for heat energy; conduction, convection and radiation. The first of these is defined as a material parameter, the others are defined within the load attributes as environmental variable and environmental temperatures. In this example, the effects of radiation are ignored.

Objectives

The objectives of the analysis are:

- To determine the maximum temperature the outer surface of the pipe reaches during continual pumping.
- To determine how long it will take for the maximum temperature to be reached once pumping of the oil begins.

Keywords

Thermal, Steady State, Transient, Environmental Temperature, Prescribed Temperature.

Associated Files



- pipe_modelling.vbs** carries out the modelling of the example.

Modelling

Running LUSAS Modeller

For details of how to run LUSAS Modeller see the heading *Running LUSAS Modeller* in the Examples Manual Introduction.

Creating a new model



Start a new model file. If an existing model is open Modeller will prompt for unsaved data to be saved before opening the new file.

- Enter the file name as **pipe**
- Use the **Default** working folder.
- Enter the title as **Steady State Thermal Analysis of Pipe**
- Select the units as **N,m,kg,s,C**
- Change the user interface to **Thermal**
- Change the startup template to **None**
- Select the **Vertical Y Axis** option and click the **OK** button.

File
New...



Note. Save the model regularly as the example progresses. Use the Undo button to correct any mistakes made since the last save was done.

Feature Geometry

The pipe geometry will be generated by defining a vertical line that will be swept into a quarter segment. This segment will then be copied to generate the full model.

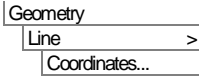

Enter coordinates of **(0, 0.1)** and **(0, 0.15)** to define a vertical line and click the **OK** button.

- Select the line

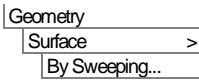

On the Sweep dialog, choose the **Rotate** option and enter a rotation angle of **90** about the **Z-axis**.

- Leave the other options and click the **OK** button.
- Select the Surface

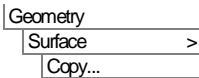

In the Copy dialog, select the **Rotate** option.

- Enter an Angle of **90** about the **Z-axis**
- Enter the number of copies as **3**
- Click **OK** to create the full pipe cross section.

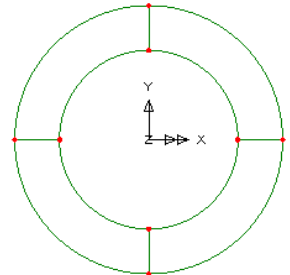



Meshing

Plane field elements are to be used for this analysis. These elements are used to model the cross section of 'infinite' components since they only model heat flow in the XY plane.

Attributes
Mesh
Surface..

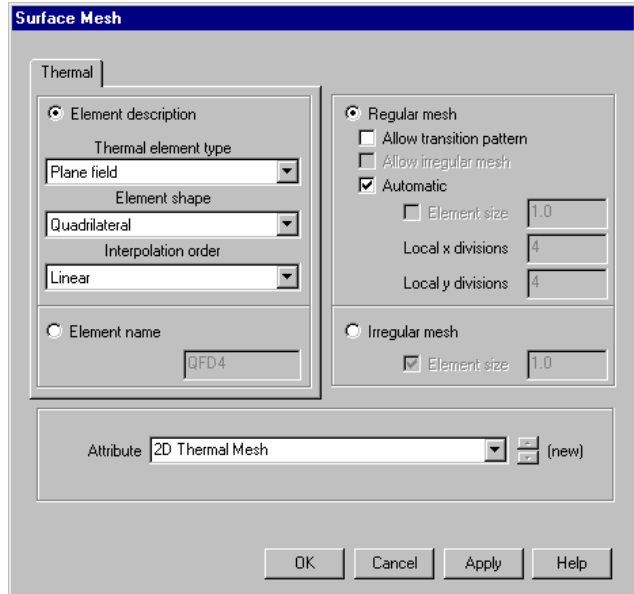
- Select **Plane field**, **Quadrilateral** shaped, **Linear** elements.
- Enter the attribute name as **2D Thermal Mesh** and click the **OK** button.



- Use **Ctrl + A** to select all the features.
- Drag and drop the mesh attribute **2D Thermal Mesh** from the  Treeview onto the selection to assign the mesh to the selected surfaces.

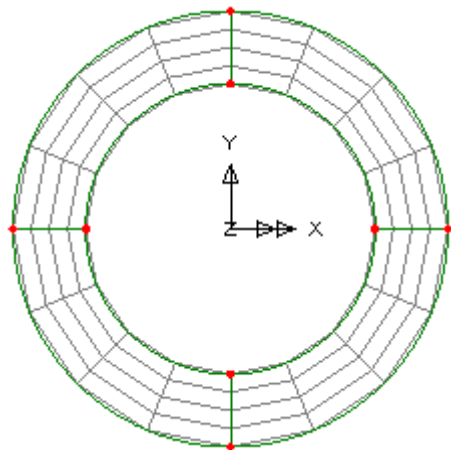

Geometric Properties

Geometric properties are used to define the thickness of the pipe. Since the pipe is of infinite length a unit length is modelled.

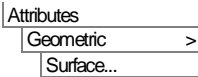

- Enter a thickness of **1** and leave the eccentricity blank.
- Enter the attribute name as **Thickness** and click the **OK** button.
- Select all the surfaces and assign the attribute **Thickness**



Select the fleshing on/off button to turn-off geometric property visualisation.

Material Properties

Within LUSAS the specific heat is defined as a massless quantity. In order to calculate this quantity, the standard specific heat capacity for a material is multiplied by the density. The result is a material parameter in the correct massless units, in this case $\text{J m}^{-3} \text{C}^{-1}$.

The materials in this example have properties of steel.

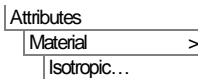

- On the Isotropic dialog enter the thermal conductivity as **60**
- Enter the specific heat as **3.7596E6**
- Enter the attribute name as **Steel (J,m,C)** and click the **OK** button.
- Assign the material attribute **Steel (J,m,C)** to the surfaces.

Boundary Conditions

Unsupported nodes in thermal analyses are assumed to be perfect insulators. The environmental conditions are defined using environmental loading. This loading defines the amount of convection to the environment that occurs.

Thermal Analysis of a Pipe

Attributes
Loading...

- Select the **Environmental Temperature** option and click **Next**

- On the Environmental Temperature dialog enter the environmental temperature as **25**

- Enter the convective heat transfer coefficient as **500**

- Since radiation is to be ignored set the radiation heat transfer coefficient to **0**

- Enter the attribute name as **Environmental Temperature** and click the **Finish** button.

- Select the 4 lines defining the outside of the pipe and assign the attribute **Environmental Temperature** to these lines. Ensure the option to **Assign to lines** is selected. Ensure **Loadcase 1** and a Load factor of **1** are selected. Click **OK** to finish the assignment.

	Environmental temperature	Convection heat transfer coefficient	Radiation heat transfer coefficient	Reference temperature
1	25	500	0	

Attribute: Environmental Temperature (new)

< Back Next > Finish Cancel Apply Help

The pipe is heated by the oil passing along inside the pipe. This is modelled using a prescribed heat input assigned to the lines defining the inner surface of the pipe.

Attributes
Loading...

- Select the **Prescribed Temperature** option and click **Next**
- On the Prescribed Temperature dialog enter a temperature of **150**
- Ensure that the **Total Prescribed** temperature loading option is selected.
- Enter an attribute name of **Oil Temperature** and click the **Finish** button.
- Select the 4 lines defining the inner surface of the pipe and assign the attribute **Oil Temperature** to these lines. Ensure the option to **Assign to lines** is selected and **Loadcase 1** is chosen with a Load factor of **1**. Click **OK** to finish the assignment

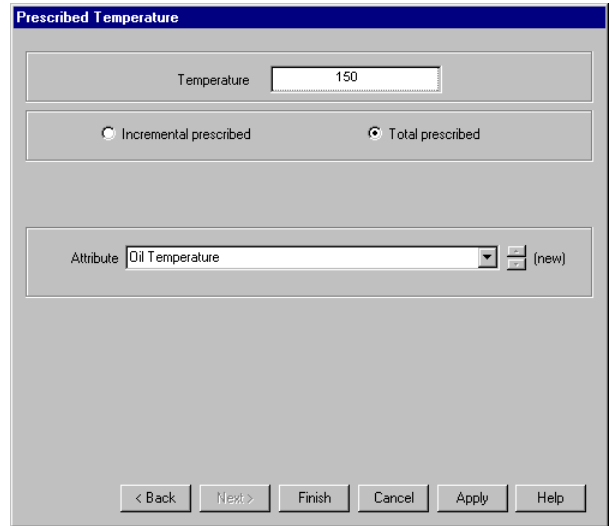

Saving the model

File
Save



Save the model file.

Running the Analysis

File
LUSAS Datafile...



A LUSAS data file name of **Pipe** will be automatically entered in the File name field.

- Ensure that the options **Solve now** and **Load results** are selected.
- Click the **Save** button to solve the problem.

A LUSAS Datafile will be created from the model information. The LUSAS Solver uses this datafile to perform the analysis.

If the analysis is successful...

The LUSAS results file will be added to  Treeview.

In addition, 2 files will be created in the directory where the model file resides:



- Pipe.out** this output file contains details of model data, assigned attributes and selected statistics of the analysis.
- Pipe.mys** this is the LUSAS results file which is loaded automatically into the Treeview to allow results processing to take place.

If the analysis fails...

If the analysis fails, information relating to the nature of the error encountered can be written to an output file in addition to the text output window. Any errors listed in the text output window should be corrected in LUSAS Modeller before saving the model and re-running the analysis.

Rebuilding a Model

If it proves impossible for you to correct the errors reported a file is provided to enable you to re-create the model from scratch and run an analysis successfully.



- Pipe_modelling.vbs** carries out the modelling of the example.



Start a new model file. If an existing model is open Modeller will prompt for unsaved data to be saved before opening the new file.

- Enter the file name as **pipe**
- Change the user interface to **Thermal**

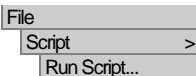



To recreate the model, select the file **pipe_modelling.vbs** located in the \<LUSAS Installation Folder>\Examples\Modeller directory.



Rerun the analysis to generate the results

Viewing the Results

If the analysis was run from within LUSAS Modeller the results will be loaded on top of the current model and the loadcase results for loadcase 1 will be set active in the  Treeview.

- Turn off the **Geometry** layer in the  Treeview.

- If necessary any visualised thermal loadings can be removed by deselecting **Visualise Assignments** from both thermal loading datasets in the  Treeview.

Temperature Contours

With no features selected, click the right-hand mouse button in a blank part of the Graphics window and select the **Contours** option to add the **Contours** layer to the  Treeview.

The contour plot properties will be displayed.

- Select **Potential** contour results component **PHI**
- Click the **OK** button.

From the analysis it can be seen that the maximum temperature the outer surface of the pipe reaches is 108.5 °C.



Note. If Plane field elements with quadratic interpolation order were to be used instead of element with linear interpolation order the true shape of the pipe would be seen. Results obtained would be the same.

This completes the steady state part of the example.

Loadcase: "1:Loadcase 1"

Results file: pipe.mys

Entity: Potential

Component: PHI

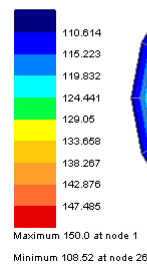

Loadcase: "1:Loadcase 1"

Results file: pipe.mys

Entity: Potential

Component: PHI

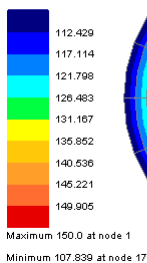

Transient Thermal Analysis

For software product(s):	Any Plus version
With product option(s):	Dynamics.

This part of the example extends the previously defined pipe model used for the steady state analysis. A file is supplied that can be used to recreate the model if required.

If you are continuing from the first part of the example you have the option to save your model file as **pipe_transient.mdl** and continue from the heading ‘Setting up the Starting Conditions’. Otherwise you can use one of the supplied scripts to re-create a suitable model as follows:

Creating a new model (if required)



 Start a new model file. If an existing model is open Modeller will prompt for unsaved data to be saved before opening the new file.

- Enter the file name as **pipe_transient**

- To create the model, import the file **pipe_modelling.vbs** located in the **<LUSAS Installation Folder>\Examples\Modeller** directory.

Setting up the Starting Conditions

The first step of a transient analysis is used to establish the steady state conditions before any heat is input. In this example this means the oil temperature needs to be removed from the first loadcase to allow the pipe to reach the environmental temperature before the oil temperature is introduced and the transient analysis begins.

- If present, turn off the Contours layer in the  Treeview
- Ensure the **Geometry**, **Mesh** and **Attributes** layers are present and turned on in the  Treeview
- In the  Treeview click the right-hand mouse button on the **Oil Temperature** attribute and choose the **Deassign> From all** option.

Now we define how the transient analysis should take place:

- Using the right-hand mouse button click on **Loadcase 1** in the  Treeview and select **Nonlinear & Transient** from the **Controls** menu.

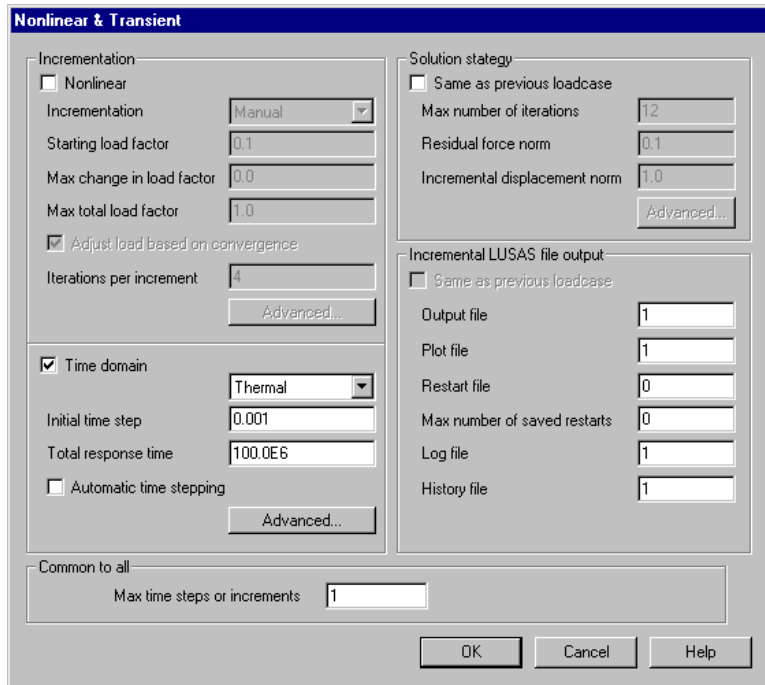

- Select the **Time domain** option.
- Ensure **Thermal** is selected in the drop down list.
- Enter an **Initial time step** of **0.001**
- Leave the Total response time set to **100E6**
- In the Common to all section, enter the **Max time steps or increments** as **1**
- Click the **OK** button.

Setting up the Transient Analysis

Once the starting conditions have been established the transient analysis can begin. The heat input is assigned to the inner surface of the pipe and the time stepping regime is defined.

Firstly reapply the environment temperature, which represents the atmospheric temperature.

- In the  Treeview click on the attribute **Environmental Temperature** with the right-hand mouse button and choose the **Select Assignments** option. This will select the lines that are currently using this attribute.

Thermal Analysis of a Pipe

- Drag and drop the attribute **Environmental Temperature** onto the graphics window to assign the attribute to **Loadcase 2** by editing the loadcase name in the drop down list. Enter a Load factor of **1** and click the **OK** button. This will introduce Loadcase 2 into the  Treeview.

Now apply the Oil Temperature.

- Select the lines defining the inner surface of the pipe.
- Assign the dataset **Oil Temperature** to these Lines selecting **Loadcase 2** with a factor of **1**. Click **OK** to finish the assignment.
- Using the right-hand mouse button click on **Loadcase 2** in the  Treeview and select **Nonlinear & Transient** from the **Controls** menu.

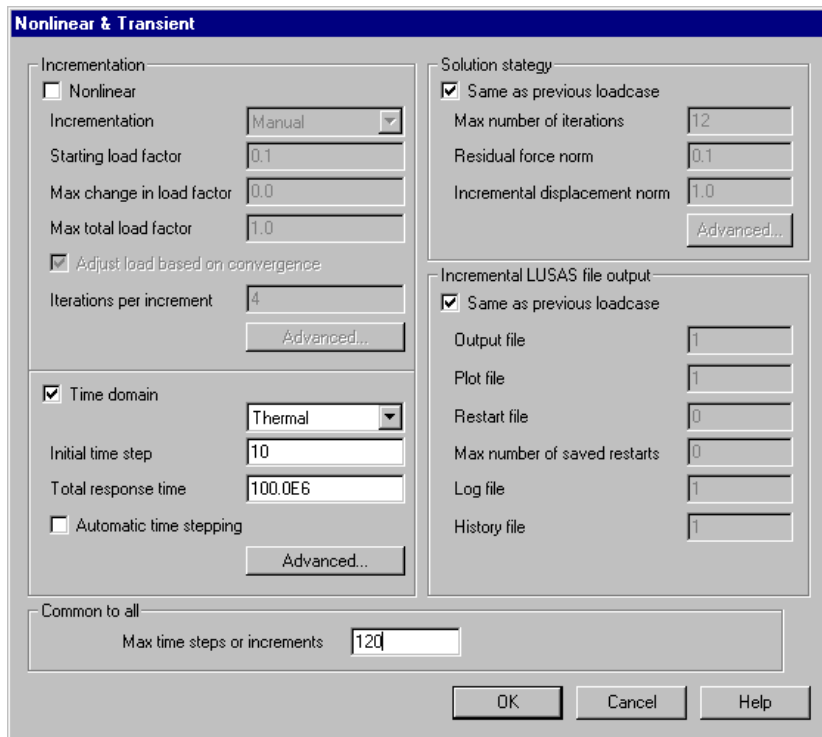

Nonlinear & Transient

Nonlinear

Incrementation: Manual

Starting load factor: 0.1

Max change in load factor: 0.0

Max total load factor: 1.0

Adjust load based on convergence

Iterations per increment: 4

Time domain: Thermal

Initial time step: 10

Total response time: 100.0E6

Automatic time stepping

Solution strategy: Same as previous loadcase

Max number of iterations: 12

Residual force norm: 0.1

Incremental displacement norm: 1.0

Incremental LUSAS file output: Same as previous loadcase

Output file: 1

Plot file: 1

Restart file: 0

Max number of saved restarts: 0

Log file: 1

History file: 1

Common to all

Max time steps or increments: 120

- Select the **Time domain** option.
- Ensure **Thermal** is selected in the drop down list.
- Enter an **Initial time step** of **10**
- In the Common to all section enter the **Max time steps or increments** as **120**

- Click the **OK** button.

Saving the model



Save the model file.

Running the Analysis



A LUSAS data file name of **pipe_transient** will be automatically entered in the File name field.

- Ensure that the options **Solve now** and **Load results** are selected.
- Click the **Save** button to solve the problem.

A LUSAS Datafile will be created from the model information. The LUSAS Solver uses this datafile to perform the analysis.

Viewing the Results

If the analysis was run from within LUSAS Modeller the results will be loaded on top of the current model and the loadcase results can be seen in the Treeview.

To establish the time taken to reach the steady state condition a graph of external temperature verse response time is to be generated.

- First, select the node on the outside of the pipe as shown.
- Choose the **Time history** option and click on the **Next** button

Select this Node

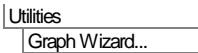
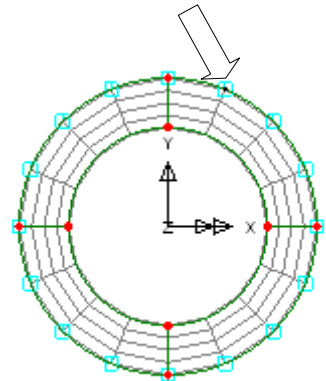

Firstly we define the X axis data.

- Select the **Named** option and click the **Next** button.
- Choose **Response Time** from the drop down list and click the **Next** button.

Then we define the Y axis data

- Select the **Nodal** option and click the **Next** button.

Thermal Analysis of a Pipe

- Select Entity **Potential** component **PHI**
- Select **Specified single node** from the Extent drop down list and the selected node number will appear in the Selected Node drop down list.
- Click the **Next** button.

It is not necessary to input the graph titles at this stage. They can always be modified later.

- Ensure **Use logarithmic scale** is not selected.
- Deselect the **Show symbols** option
- Click on the **Finish** button to display the graph showing the variation of

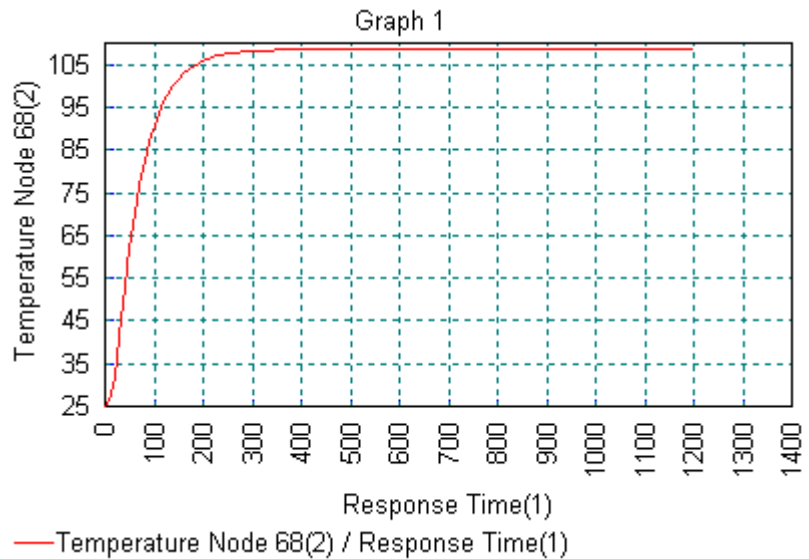

temperature on the outer surface of the pipe with time.

It can be seen that the outside of the pipe reaches its steady state condition after approximately 300 seconds.

This completes the transient thermal example.

Linear Analysis of a Composite Strip

For software product(s):	LUSAS Composite Plus
With product option(s):	None

Description

A 50mm x 10mm x 1mm thick composite strip, composed of an 8-layer composite material is to be analysed first using shell elements and then using solid elements in order to compare the results obtained.

The strip is loaded with a global distributed line load of 10N/mm on the centreline as shown. The composite strip has two axes of symmetry therefore only a quarter of the strip needs to be modelled. Symmetry boundary conditions are to be simulated by applying supports on the appropriate Lines. The geometry of the strip and support positions are as shown.

Units used are N, mm, t, s, C throughout.

- Analysis 1** Surface features meshed with thick shell composite elements.
- Analysis 2** Volume features meshed with solid composite elements

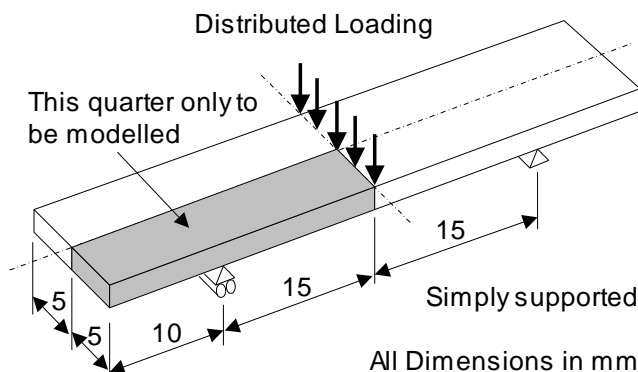

Objectives

The output from the shell analysis will consist of:

- Deformed Mesh Plot showing displacements with peak values annotated.
- Bending Stress Contour Plot showing the direct stresses on the bottom Surface.

The output from the solid analysis will consist of:

- Deformed Mesh Plot showing displacements with peak values annotated.
- Bending Stress Contour Plot showing the direct stress on the bottom Surface of layer 1.
- Shear Stress Contour Plot showing the interlamina shear stress on the top Surface of layer 1.

Keywords

2D, 3D, Composite, Shell, Solid, Lay-up, Interlamina Shear, Failure Criteria, Tsai-Wu

Associated Files



- strip_shell_modelling.vbs** carries out the modelling of the example using shell elements.
- strip_solid_modelling.vbs** carries out the modelling of the example using solid elements.

Modelling : Shell Model

Running LUSAS Modeller

For details of how to run LUSAS Modeller see the heading *Running LUSAS Modeller* in the Examples Manual Introduction.



Note. This example is written assuming a new LUSAS Modeller session has been started. If continuing from an existing Modeller session select the menu command **File>New** to start a new model file. Modeller will prompt for any unsaved data and display the New Model dialog.

Creating a new model

- Enter the file name as **strip_shell**
- Use the **Default** working folder.
- Enter the title as **Composite Strip - Shell Model**
- Set the units to **N,mm,t,s,C**
- Ensure a **Structural** User interface is selected.

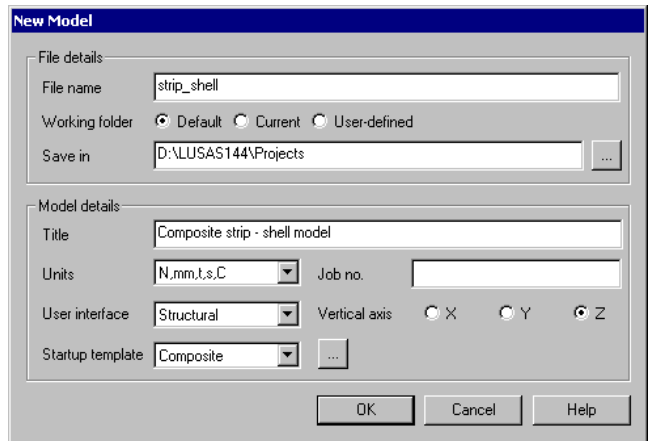

- Select the **Composite** startup template
- Select the **Vertical Z axis** option and click the **OK** button.





Note. Selecting the startup template Composite will add useful composite specific modelling data to the Treeview.

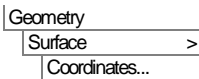

Note. Save the model regularly as the example progresses. Use the Undo button to correct any mistakes made since the last save was done.

Defining the Geometry



 Enter coordinates of **(0,0)**, **(10,0)**, **(10,5)** and **(0,5)** and click **OK** to define the first Surface.

- Select the Line on the right hand side as shown.

Select this Line

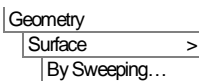
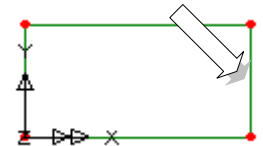

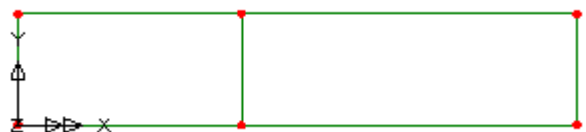

 Enter a translation distance of **15** in the **X** direction.

- Click the **OK** button to create a new Surface.



Meshing

The Surfaces are to be meshed using thick shell elements. LUSAS provides a composite surface mesh attribute by default. This can be seen in the  Treeview. A thick shell element (QTS4) is used.

- Select the whole model. (Using the **Ctrl** and **A** keys together).
- Drag and drop the surface mesh attribute **Composite Shell** from the  Treeview onto the selected features.

Modeller will draw a mesh based upon a default of 4 Line divisions per Line. This mesh density will be altered by using Line mesh datasets.

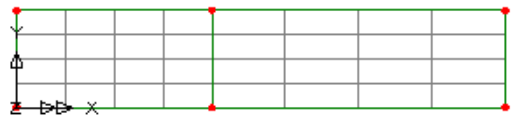



Note. A number of Line mesh attribute are provided by LUSAS by default. These can simply be dragged and dropped onto the features to which they are to be assigned.

With the whole model selected:

- Drag and drop the Line mesh attribute **Divisions=2** from the  Treeview onto the selected features.

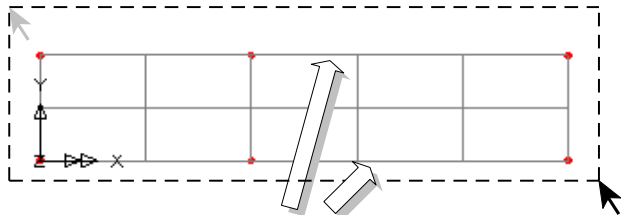
Select all Lines for Line mesh 'Divisions=2'



- Select the 2 horizontal Lines on the right-hand side of the model. (Hold the Shift key down to add to the initial line selection).
- Drag and drop the Line mesh attribute **Divisions=3** from the  Treeview onto the selected features. This overwrites the previous Line mesh assignment.

Select these 2 Lines for Line mesh 'Divisions=3'

Checking Local Element Directions

In creating the second Surface from the first the orientation of the Surface axes will not necessarily be the same. In this example the local element directions should be checked because the composite lay-ups which are defined later in this example are assigned to the model using the local element axes.



Use the isometric rotation button to rotate the model to a similar view to that shown.



Note. If manually rotating the model pressing the **Ctrl** key at the same time will rotate the model in the plane of the screen.

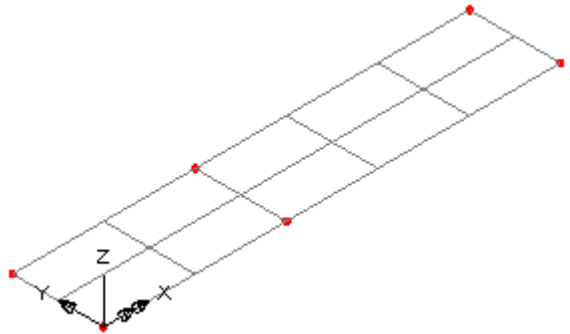

- In the  Treeview double click **Mesh** and select the **Show element axes** option.
- Click the **OK** button to display the element axes.

The element axes in the right-hand section of the model need to be re-oriented to lie along the global X axis.

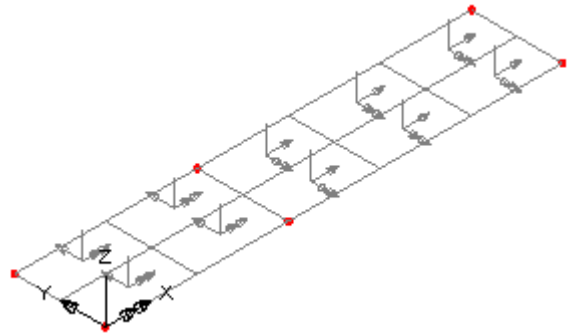

Changing the Element Directions

- Select the right-hand Surface of the model.

The orientation of the elements needs to be rotated to align them with the global X axis.

- Click **Apply** to rotate the axis by 90 degrees each time, until the x axis match with those of the left-hand surface.

The orientation of the elements will rotate to align the with the global Y axis.

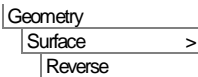
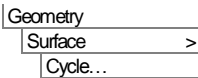

- In the  Treeview double click the **Mesh** layer.

The mesh properties dialog will appear.

- De-select the **Show element axes** option and click the **OK** button.

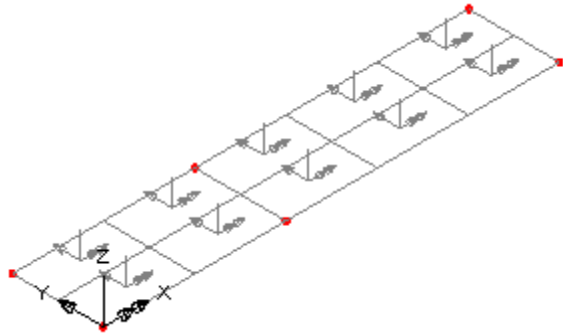

Defining the Geometric Properties

The strip is 1mm thick. A geometric property attribute of unity thickness is provided by default. This can be used to define the thickness of the Surfaces.

- Select the whole model and drag and drop the geometry attribute **Unit Thickness** from the  Treeview onto the selected features. If the fleshing option is turned on the assigned geometric property will be automatically visualised.



Select the fleshing on/off button to turn-off geometric property visualisation.



Note. Once assigned to the model, attributes such as geometric assignments may be visualised.

- In the  Treeview click the right-hand mouse button on the geometry attribute **Unit Thickness**. Select **Visualise Assignments** to show where the attribute has been assigned to the model.
- Follow a similar process and deselect **Visualise Assignments** to hide the attribute display again.

Defining the Composite Material Properties

The material properties of the strip will be modelled as a composite lay-up made up from 8 lamina each defined as an orthotropic material. Whilst LUSAS provides a range of composite material types by default this example is based upon a test study and requires specific material data to be defined.

To define the orthotropic material:

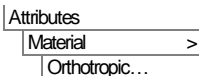

Orthotropic

Using the following properties

Plastic Creep Damage Shrinkage Viscous Two phase

Elastic

Model: 6 - Solid

Thermal expansion
 Dynamic properties

	Value
Young's modulus x	1e5
Young's modulus y	5000
Young's modulus z	5000
Shear modulus xy	3000
Shear modulus yz	2000
Shear modulus xz	2000
Poisson's ratio xy	0.4
Poisson's ratio yz	0.3
Poisson's ratio xz	0.3
Mass density	

Attribute: Strip material (new)

OK Cancel Apply Help

- With the **Elastic** tab displayed, select a **Solid** model from the drop down list.
- Enter the Young's Modulus in the **X** direction as **1E5**, in **Y** as **5000** and in **Z** as **5000**
- Enter the shear modulus in the **XY** plane as **3000**, and in **YZ** and **ZX** as **2000**
- Finally, enter Poisson's ratio as **0.4** in the **XY** plane, and **0.3** in the other two planes. It is not necessary to enter the mass density.
- Enter the attribute name as **Strip Material** and click the **OK** button to add the material attribute to the  Treeview. This will be assigned to the model later in the example.

Defining the Composite Lay-up Arrangement

Details of the composite stack are shown in the attached table. The stack is symmetrical about the mid plane. This enables the input of the stack to be reduced by using the symmetric option.

Lamina Name	Thickness	Angle
Lamina1	0.1	0
Lamina2	0.1	90
Lamina3	0.1	0
Lamina4	0.2	90

Attributes
Composite...

- Select the **Solids and Shells** option and click **Next**
- Ensure that the **Normal** tab is displayed for shells and solids.
- Select the **New** button to enter the composite lay-up details.

Solids and Shells

Normal | Grid

Layer

1 Of 0 [New...] [Insert...] [Delete]

Name

Material Strip material

Thickness 0.0

Angle 0.0

Composite lay-ups are defined with lamina 1 at the bottom

Symmetric [Visualise...]

Automatic lamina names based on prefix Lamina [Reverse]

Attribute (new)

< Back Next > Finish Cancel Apply Help

The Add Lamina dialog will appear.

The Name for the first lamina will be automatically entered as **Lamina1**

The material will automatically be entered as **Strip material**

- Change the lamina thickness to **0.1**
- Enter the angle as **0**
- Click the **Apply** button to define the lamina.

Enter lamina 2, 3 and 4 in a similar manner using the values in the previous table. Click **Apply** after each lamina is defined. Note layer 4 has a different thickness to the other layers. Click **OK** when all are defined.

- On the Solids and Shells dialog select the **Symmetric** option.
- Enter the composite attribute name as **Strip Layup**

Now check the composite input

- On the Composite Materials dialog, select the **Grid** tab.
- Ensure that the values are as shown. Correct on this grid if necessary.

	Lamina name	Thickness	Angle	Material name
1	Lamina1	0.1	0	Strip material
2	Lamina2	0.1	90	Strip material
3	Lamina3	0.1	0	Strip material
4	Lamina4	0.2	90	Strip material
5	Lamina4_symm	0.2	90	Strip material
6	Lamina3_symm	0.1	0	Strip material
7	Lamina2_symm	0.1	90	Strip material
8	Lamina1_symm	0.1	0	Strip material



Note. Whilst this example shows laminate thicknesses being defined that sum-up to the geometric thickness of the strip, lamina thicknesses for shell models that have been assigned a geometric thickness are actually relative values, not absolute, and represent the proportion of the total thickness (as specified by geometric surface properties) apportioned to each lamina.

Visualising the Composite Lay-up arrangement

- On the Solids and Shells dialog, select **Visualise** to view the lay-up sequence.
- Click the **Close** button to return to the Composite Materials dialog.
- Click the **Finish** button to add the composite material attribute to the  Treeview.



Note. The lay-up sequence always builds from the bottom to the top. In this example, Laminal 1 is the bottom lamina in the stack.



Note. Composite lay-up data may also be defined in external spreadsheets for copying and pasting into the composite layup Grid using the standard copy (Ctrl + C) and paste (Ctrl + V) keys.

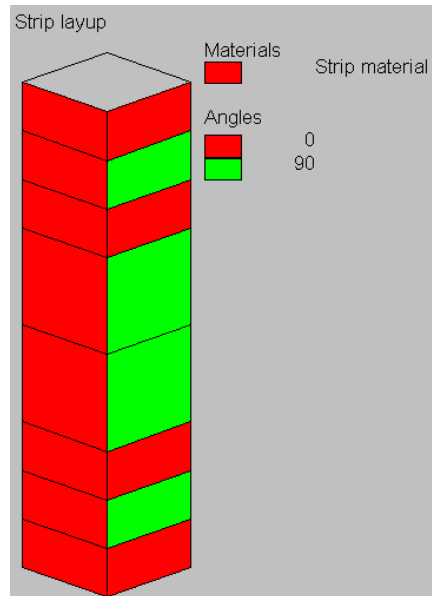

Assigning the Composite Lay-up Arrangement

- To assign the composite attribute to the model, drag a box around the model to select all the features.
- Drag and drop the attribute **Strip Lay-up** from the  Treeview onto the selected features.
- On the Assign Composite dialog, ensure that **Assign to Surfaces** and that **Local Element Axes** are selected.
- Click the **OK** button.





Note. In a composite analysis, assigning the composite material lay-up automatically assigns the material attribute to the model at the same time. The composite material attribute therefore does not have to be directly assigned to features.



Checking the composite orientation

To check the orientation of each composite lamina is correct.

- Select the  Treeview and double click on the **Attributes** entry to display the attribute layer properties.
- Select the **Composite** tab and select the **Strip Layup** check box option.
- Click on the **Settings** button and ensure the option to **Visualise ply directions** is selected.
- Click **OK** and **OK** again.
- In the  Treeview expand the Composite Strip layup entry and right-click on the lamina you wish to check and **Set Lamina Active**
- When you are satisfied the orientations are correct deselect this visualisation by selecting the  Treeview, double clicking on the **Attributes** entry, selecting the **Composite** tab and deselecting the **Strip Layup** option.

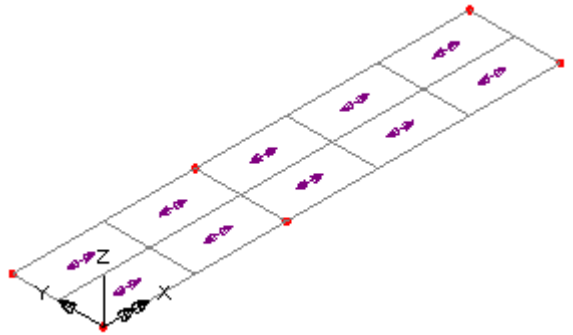

Supports

LUSAS provides the more common types of support by default. These can be seen in the  Treeview. The model will be supported in the Z direction at the internal Line between the two Surfaces.

- Select the internal Line shown
- Drag and drop the support attribute **Fixed in Z** from the  Treeview onto the selected feature, click **OK** ensuring that it is assigned to **All loadcases**

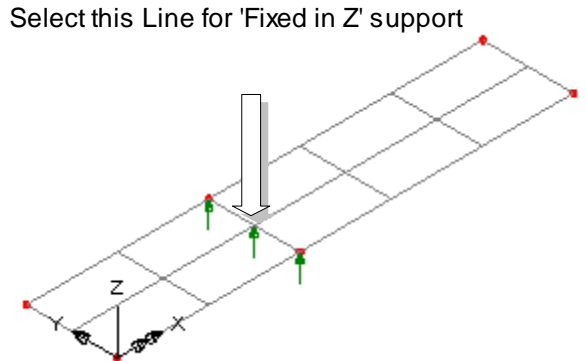

The supports will be

visualised.

Defining Symmetry Support Conditions

LUSAS provides symmetry boundary conditions by default. These can be seen in the  Treeview. As only a quarter of the structure has been modelled the symmetry boundary conditions are assigned to two sides of the model.

- Select the 2 upper Lines of the model as shown
- Drag and drop the support attribute **Symmetry XZ** from the  Treeview onto the selected features.
- Click **OK** to visualise the supports.

Select these 2 Lines for support
'Symmetry XZ Plane'

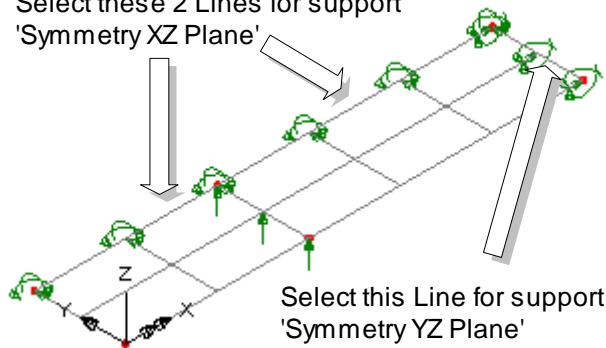

- Select the right-hand Line of the model as shown.
- Drag and drop the support attribute **Symmetry YZ** from the  Treeview onto the selected Line.
- Click **OK** to visualise the supports.

Loading



The model will be subjected to a load per unit length of 5 N/mm acting in the negative Z direction along the right-hand line which represents the mid-span centre-line of the strip.



Note. The composite strip is modelled using a quarter model and the Line of load application coincides with one of the Lines of symmetry. The value of applied load is therefore half of that applied to the full model.

- Select the **Global Distributed** option and click **Next**
- On the Global Distributed dialog select the **Per Unit Length** option.
- Enter a value of **-5** in the **Z** direction.
- Enter the attribute name as **Global Distributed**

Attributes
Loading...

- Click the **Finish** button to add the loading attribute to the  Treeview.
- Select the Line on the right of the model as shown.
- Drag and drop the loading attribute **Global Distributed** from the  Treeview onto the selected Line.
- Click the **OK** button to assign the load to the selected Lines and to accept the default loadcase.

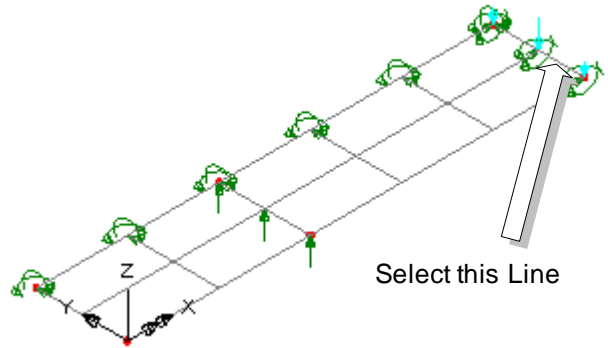

The loading will be visualised.

Saving the model

The model is now complete and the model data must be saved.



Save the model file.

Running the Analysis

With the model loaded:



A LUSAS data file name of **strip_shell** will be automatically entered in the File name field.

- Ensure the **Solve now** and **Load results** options are selected.
- Click the **Save** button to finish.

A LUSAS Datafile will be created from the model information. The LUSAS Solver uses this datafile to perform the analysis.

If the analysis is successful...

The LUSAS results file will be added to  Treeview.

In addition, 2 files will be created in the directory where the model file resides:



- ❑ **strip_shell.out** this output file contains details of model data, assigned attributes and selected statistics of the analysis.
- ❑ **strip_shell.mys** this is the LUSAS results file which is loaded automatically into the  Treeview to allow results processing to take place.

If the analysis fails...

If the analysis fails, information relating to the nature of the error encountered can be written to an output file in addition to the text output window. Any errors listed in the text output window should be corrected in LUSAS Modeller before saving the model and re-running the analysis.

Rebuilding a Model

If it proves impossible for you to correct the errors reported a file is provided to enable you to re-create the model from scratch and run an analysis successfully.



- ❑ **strip_shell_modelling.vbs** carries out the modelling of the example.

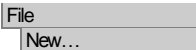

Start a new model file. If an existing model is open Modeller will prompt for unsaved data to be saved before opening the new file.

- Enter the file name as **strip_shell**

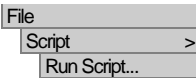

To recreate the model, select the file **strip_shell_modelling.vbs** located in the **\<LUSAS Installation Folder>\Examples\Modeller** directory.



Rerun the analysis to generate the results

Viewing the Results



If necessary, use the isometric rotation button to rotate the model to a similar view to that shown.

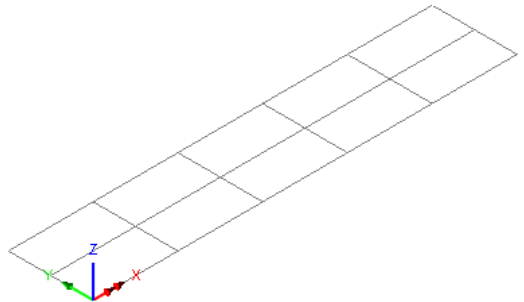

Plotting peak vertical displacements

- In the Treeview turn off the **Attributes** and **Geometry** layers by right-clicking on the layer name and selecting the On/Off menu item.
- With no features selected click the right-hand mouse button in a blank part of the Graphics window and select **Values** to add the Values layer to the Treeview.

The values properties dialog will be displayed.

- With the **Value Results** tab selected, select entity results for **Displacement** of component **DZ**. (Displacement in the Z direction).
- Select the **Values Display** tab, de-select Maxima and specify that **0 %** of the **Minima** displacement values are to be plotted
- Click the **OK** button to display peak values of vertical displacement.
- Turn off the **Values** layer in the Treeview.

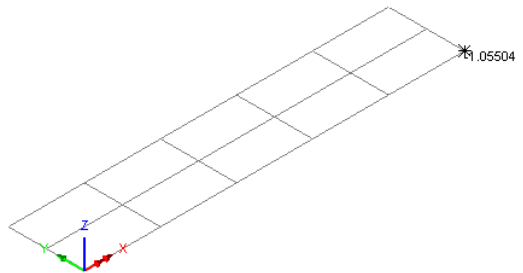

Stress contour plots for lamina



Note. For shell models the lamina results are output for the middle of each lamina selected.

Linear Analysis of a Composite Strip

- Click the right-hand mouse button in a blank part of the graphics window and select **Contours** to add the contours layer to the  Treeview.

The Contour Properties dialog will be displayed.



- Select the **Stress - Thick Shell lamina** entity of stress **Sx**





Note. By default, the stresses will be calculated in the lamina material direction. The Transform button on the Contour Properties dialog can be used to transform stresses into global or user defined directions.

- Click the **OK** button to display contours and the associated contour key.

- In the  Treeview, in the Composite Strip Layup section, right-click on **Lamina1** and **Set Lamina Active**. The contour key should be showing a maximum value of 519.1

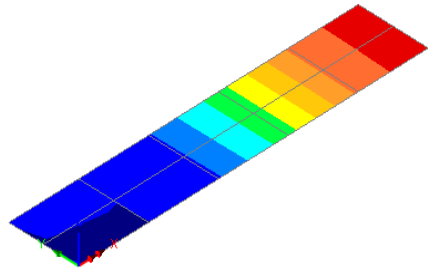
- To display the mesh on top of the contours select the **Mesh** entry in the  Treeview and drag on drop it on top of the **Contour** entry in the  Treeview.



- By selecting different lamina from the Composite Strip layup entry in the  Treeview, the stresses throughout the composite strip can be investigated.



Note. Because there are discontinuities between laminae the stress plots produced will always be for un-averaged results.

Interlamina shear plots

- In the  Treeview double-click the **Contours** layer to display the contour layer properties.
- Select the **Stress - Thick Shell lamina** entity of stress **Szx**

- Click the **OK** button to display contours and the associated contour key for the active lamina.

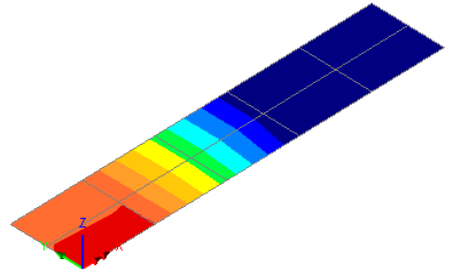

Modelling : Solid Model

The composite strip in this example is now to be modelled using solid composite brick elements meshed onto Volumes. This is to compare the accuracy of the results obtained for each modelling method.

If successfully created in the first part of this example, the shell composite model can be extended to create the solid composite model. If the model was not successfully created a suitable model can be built from a supplied file. See below for details.

Extending the current shell model

 To continue directly from the shell model toggle the menu entry **Utilities>Mesh>Mesh Lock** to ensure the Mesh Lock option is deselected and click **Yes** to confirm the closing of the results files.

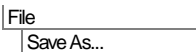

- Enter the model file name as **strip_solid** and click the **Save** button.
- Ensure that only the **Geometry**, **Attributes** and **Mesh** layers are present and turned on in the  Treeview.

Creating a suitable model from a supplied file

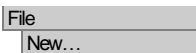

 Start a new model file. If an existing model is open Modeller will prompt for unsaved data to be saved before opening the new file.

- Enter the file name as **strip_solid**

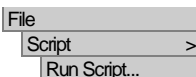

To recreate the model, import the file **strip_shell_modelling.vbs** located in the **\<LUSAS Installation Folder>\Examples\Modeller** directory.

Changing the model description



- Change the model description to **Composite strip - solid model** and click **OK**

Converting the Model from Shells to Solids

To convert the 2D model that uses Surfaces into a 3D model that uses Volumes a number of attributes assigned to the 2D model need to be deassigned. This is to prevent them being copied when the Surfaces are swept to create a 3D model.





Note. In the following tasks, take care to deassign and NOT delete the Loading, Support attribute, Composite strip lay-up attribute or the Geometric material attribute from the  Treeview.

Deassigning the loading

- In the  Treeview click the right-hand mouse button on the loading attribute **Global Distributed** and select **Deassign>From all**

Deassigning the supports

- In the  Treeview, click the right-hand mouse button on the support attribute **Fixed in Z**, and select **Deassign>From all**
- In the  Treeview, click the right-hand mouse button on the support attribute **Symmetry XZ**, and select **Deassign>From all**.
- In the  Treeview, click the right-hand mouse button on the support attribute **Symmetry YZ**, and select **Deassign>From all**.

Deassigning the composite material arrangement

- Using the method described previously, deassign the composite attribute **Strip Layup** from the model.



Deassign the geometry

- Using the method described previously, deassign the geometry attribute **Unit Thickness** from all Surfaces on the model.

Deassigning the Surface mesh

- Using the method described previously, deassign the surface mesh attribute **Composite Shell** from the model.



Note. When the an attribute is de-assigned from the model such that it is not used on any feature the assigned attribute symbol will change from its coloured form  to its unassigned grey form .

In the  Treeview the only assigned attribute left after this de-assignment process should be the 2 and 3 line mesh divisions and the strip material.

Default mesh divisions

The Lines on the model have been assigned different Line mesh divisions earlier in the example. However, the default number of line mesh divisions is still set by default to be 4. If the existing surfaces were swept to create volumes any newly created lines between the top and bottom surfaces would have the default of 4 mesh divisions per line assigned to them when in fact only one mesh division per line is required.

To adjust the default number of mesh divisions

- Select the **Meshing** tab. Set the default number of divisions to be **1** and click **OK**

File
Model Properties...

Modifying the Geometry

The 2D model will now be swept into 3D by sweeping the existing two Surfaces to create two Volumes.

- Select the whole model.



Enter a translation in the **Z** direction of **1** and click **OK**



If necessary use the isometric rotation button to rotate the model as shown.

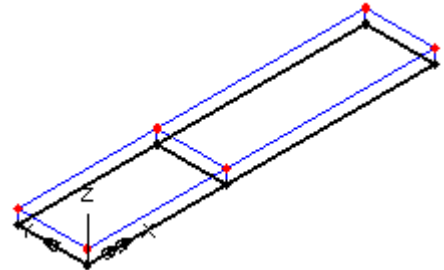

Geometry
Volume >
By Sweeping...



Note. With Composite analysis models the thickness of the volume defines the thickness of the strip and no geometric property thickness is required to be assigned to the model.

Whilst this example shows laminate thicknesses being defined that sum-up to the thickness of the volume, lamina thicknesses for solid models comprised of pentahedral and hexahedral composite elements are relative, not absolute, and represent the proportion of the total space that the elements of the volume represent apportioned to each lamina.

Meshing

A Volume mesh is to be defined. LUSAS provides a number of volume mesh attribute by default. These can be seen in the  Treeview. The composite brick element to be used has a hexahedral element shape and a quadratic interpolation order.

Linear Analysis of a Composite Strip

- Select the whole model
- Drag and drop the Volume mesh attribute **Composite Brick (HX16L)** from the  Treeview onto the selected features.



Note. The Line mesh divisions (defined in the shell model of this example) are used to create the mesh arrangement for the top and bottom Surfaces. The default number of Line mesh divisions are used for each swept Line on the side Surfaces.

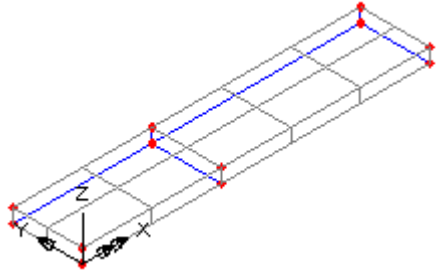

Assigning Composite Properties

- With the whole model selected, drag and drop the Composite material attribute **Strip Lay-up** from the  Treeview onto the selected features ensuring that it is assigned to **Volumes** using **Local element axes**. Click **OK** to carry out the assignment.



Note. The lamina thicknesses for solid models comprised of pentahedral and hexahedral composite elements are relative values, not absolute, and represent the proportion of the total space that the elements of the volume represent apportioned to each lamina.

Loading

- Select the upper Line shown right.
- Drag and drop the loading attribute **Global Distributed** from the  Treeview onto the selected feature and click **OK**

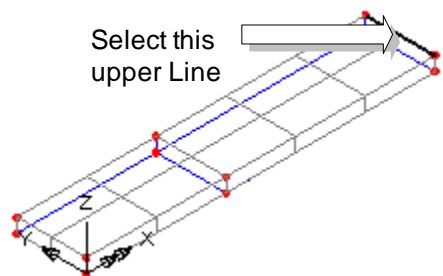

Supports

- Select the lower internal line as shown.
- Drag and drop the support attribute **Fixed in Z** from the  Treeview onto the selected feature, Click **OK** ensuring that **Assign to lines** is selected for **All loadcases**

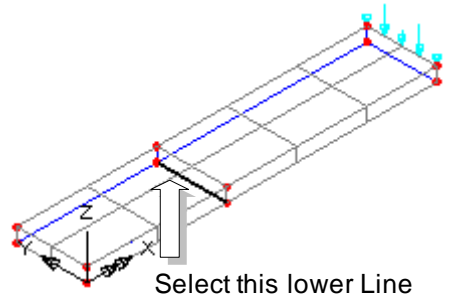

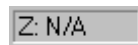

In order to model the boundary conditions the supports must be assigned to the Surfaces that are, in effect, axes of symmetry for the entire strip. These supports are easier to assign on a view along the global Z axis.

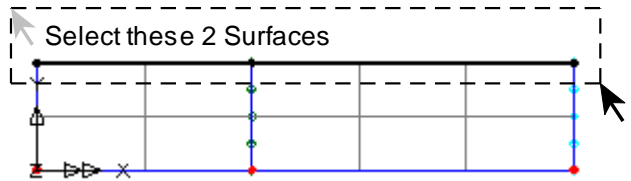

Set the view direction along the global Z axis by pressing the Z axis button on the status bar at the bottom of the graphics window.

- Drag a box around the 2 upper Surfaces of the model and drag and drop the support attribute **Symmetry XZ** from the  Treeview onto the selected features, Click **OK** ensuring that **Assign to surfaces** is selected for **All loadcases**



- Drag a box around the right-hand Surface of the model and drag and drop the support attribute **Symmetry YZ** from the  Treeview onto the selected features, Click **OK** ensuring that **Assign to surfaces** is selected for **All loadcases**

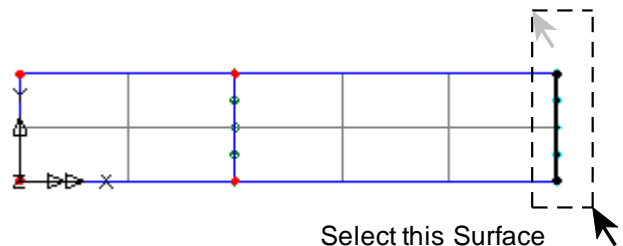



To view the applied supports use the isometric rotation button.

Save the model

The model is now complete.



Save the model file.

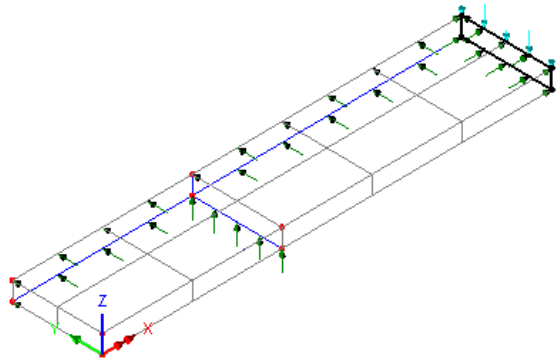

File
Save

Running the Analysis

With the model loaded:



A LUSAS data file name of **strip_solid** will be automatically entered in the File name field.

File
LUSAS Datafile...

- Ensure the **Solve now** and **Load results** options are selected.
- Click the **Save** button to finish.

A LUSAS Datafile will be created from the model information. The LUSAS Solver uses this datafile to perform the analysis.

If the analysis is successful...

The LUSAS results file will be added to Treeview.

In addition, 2 files will be created in the directory where the model file resides:



- strip_solid.out** this output file contains details of model data, assigned attributes and selected statistics of the analysis.
- strip_solid.mys** this is the LUSAS results file which is loaded automatically into the Treeview to allow results processing to take place.

If the analysis fails...

Use a text editor to view the output file and search for 'ERROR'. Any errors listed in the output file should be fixed in LUSAS Modeller before saving the model and re-running the analysis.

Rebuilding the Model

If errors are listed that for some reason you cannot correct, a file is provided to re-create the model information correctly, allowing a subsequent analysis to be run successfully.



- ❑ **strip_solid_modelling.vbs** carries out the modelling of the example.

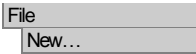

Start a new model file. If an existing model is open Modeller will prompt for unsaved data to be saved before opening the new file.

- Enter the file name as **strip_solid**

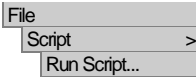

To recreate the model, select the file **strip_solid_modelling.vbs** located in the **\<LUSAS Installation Folder>\Examples\Modeller** directory.

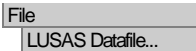

Rerun the analysis to generate the results

Viewing the Results

- Ensure that only the **Geometry**, **Attributes** and **Mesh** layers are present and turned on in the Treeview.

If necessary, use the isometric rotation button to rotate the model as shown.

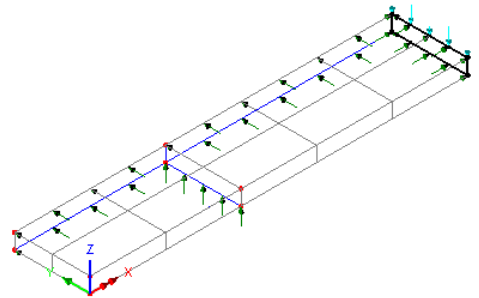

Plotting peak vertical displacements

- With no features selected click the right-hand mouse button in a blank part of the graphics window and select **Values** to add the values layer to the Treeview.

The values properties dialog will be displayed.

- With the **Value Results** tab selected, select **Displacement** results of displacement in the Z direction, **DZ**
- Select the **Values Display** tab, de-select Maxima and specify that **0 %** of the **Minima** displacement values are to be plotted.

Linear Analysis of a Composite Strip

- Click the **OK** button to display the peak values of vertical displacement.
- Turn off the **Values** layer in the  Treeview.

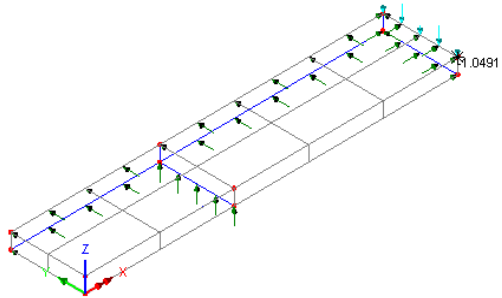

Stress contour plots for lamina



Note. For solid models the lamina results can be selected for the top, middle or the bottom of any selected lamina.

- With no features selected click the right-hand mouse button in a blank part of the graphics window and select **Contours** to add the contours layer to the  Treeview.

The contour Properties dialog will be displayed.

- Select entity results of **Stress - Solids lamina (bottom)** of component **Sx** and click the **OK** button.
- In the  Treeview expand the Composite Strip layup entry and right-click on the **Lamina1** and **Set Lamina Active**

The contour key should be showing a maximum stress in the lamina X direction of 679.4

- By re-ordering the layers in the  Treeview the mesh can be viewed on top of the contour results.

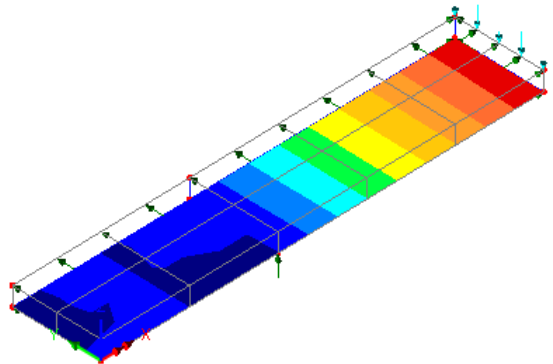

Interlamina shear plots

- In the  Treeview double-click the **Contours** layer to display the contour layer properties.
- Select **Stress - Solids lamina (top)** contour results of stress **Szx**
- Click the **OK** button to update the contours and the contour key to show the minimum value of -8.06 for Lamina 1.

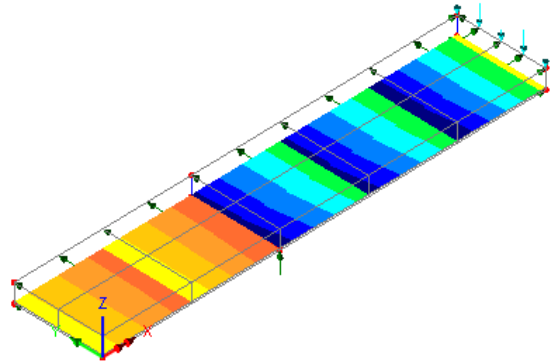

Defining Failure Strength

Composite
Composite Failure...

The failure strength dialog will appear.

- Enter the Dataset title as **Layer Strength**
- Enter the Longitudinal Tensile Strength as **1978**
- Enter the Transverse Tensile Strength as **48.69**
- Enter the Longitudinal Compressive Strength as **1978**
- Enter the Transverse Compressive Strength as **48.69**
- Enter the Shear Strength as **133**
- Leave the interaction type as **Default** and click **OK**

Failure Strength	
Longitudinal Tensile Strength	1978
Transverse Tensile Strength	48.69
Longitudinal Compressive Strength	1978
Transverse Compressive Strength	48.69
Shear Strength	133
Interaction Type	Default
Interaction Term	5.19163E-6
Title	Layer Strength
<input type="button" value="OK"/> <input type="button" value="Cancel"/> <input type="button" value="Help"/>	

Assigning Failure Strength

The failure strength is assigned to the geometry.

- Select the whole model.
- From the  Treeview drag and drop **Layer Strength** onto the selected features and click **OK** to **Assign to volumes**

Plotting contours of Failure Criteria

- In the  Treeview double-click the **Contours** layer.
- Select **Stress - Solids lamina (bottom)** contour results of Tsai-Wu failure, **Tsai Wu**. By default, the stresses will be shown in the laminate material direction.
- Select the **Contour Display** tab and pick the **Contour Key Details** button, change the number of significant figures to **2** and deselect the **Show minimum value** option.
- Click **OK** to update the contour key details and **OK** again to display contours of the Tsai Wu failure criteria.



Note. Values greater than unity show that the material has exceeded the failure criteria.

In this example the maximum failure value (shown on the contour key) is only 0.165 so no failure has occurred due to the applied loading.

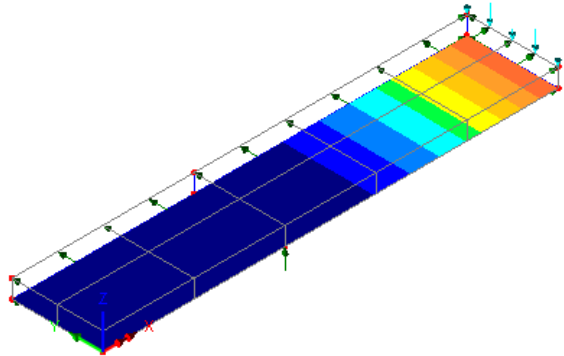

This completes the example.

Damage Analysis of a Composite Plate

For software product(s):	LUSAS Composite Plus
With product option(s):	Nonlinear.
Note: The example exceeds the limits of the LUSAS Teaching and Training Version.	

Description

A 1mm thick composite plate made up from an IM Carbon cross ply laminate is placed under tensile loading to analyse the damage growth and stress redistribution around a stress concentration caused by a 10mm diameter hole. Because of symmetry a quarter model will be created.

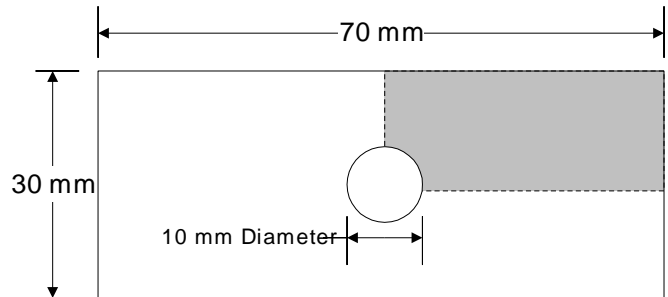

Units used are N, mm, t, s, C throughout.

Objectives

The objective of the analysis is:

- To determine the onset of damage growth
- To predict the effect of damage growth on the stress distribution within the composite stack

Keywords

Composite, Hashin, Damage, Nonlinear

Associated Files



- ❑ **composite_plate_modelling.vbs** carries out the modelling of the example.

Modelling

Running LUSAS Modeller

For details of how to run LUSAS Modeller see the heading *Running LUSAS Modeller* in the Examples Manual Introduction.



Note. This example is written assuming a new LUSAS Modeller session has been started. If continuing from an existing Modeller session select the menu command **File>New** to start a new model file. Modeller will prompt for any unsaved data and display the New Model dialog.

Creating a new model

- Enter the file name as **composite_plate**
- Use the **Default** working folder.
- Enter the title as **Damage Analysis of Composite Plate**
- Set the units as **N,mm,t,s,C**
- Select the User Interface **Structural**
- Select the Startup template **Composite**
- Select the Vertical **Z** axis.
- Click the **OK** button.



Note. Save the model regularly as the example progresses. Use the Undo button to correct any mistakes made since the last save was done.

Feature Geometry

The composite plate will be modelled as a quarter model and symmetry boundary conditions will be used to reduce the size of the model. Firstly the hole will be defined.

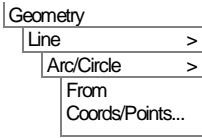

- Enter coordinates of **(5, 0)**, **(0, 5)** and **(0, 0)**
- Select the **Centre** option next to the **(0, 0)** coordinate entry and click the **OK** button.

Now define the lines representing the edges of the specimen.

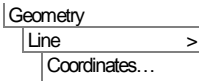

-  Enter coordinates of **(35, 0)**, **(35, 15)** and **(0,15)** and click the **OK** button.

Now create the lines on the symmetry planes.

- Select the two points on the horizontal plane of symmetry

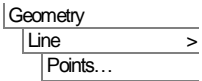
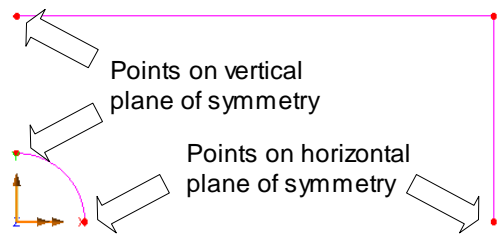

-  Create a line along the horizontal line of symmetry.

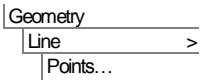

- Select the two points on the vertical plane of symmetry.





-  Create a line along the vertical line of symmetry.

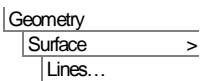

Now create a surface from the boundary lines.

- Change the selection mode so only Lines are selected from the display. Click and hold the left-hand mouse button on the selection button , then click on the  button to select only lines.
- Box-select all the lines in the model by clicking and dragging the cursor around all the lines that form the surface.





-  Create a surface from the selected lines.

- Change the selection mode back to the default pointer  and click in a blank area of the view window to deselect any selected features.

Meshing

In this example the mesh will be graded manually by specifying the number of elements on each of the boundary lines. The mesh pattern will not be visible until a volume mesh assignment has been made.

Define a null line mesh with 16 divisions.

- Enter **16** in the number of divisions.
- Enter the dataset name as **Divisions=16** and click the **OK** button.
- Use the **Ctrl** and **A** keys together to select all the features and assign **Divisions=16** from the  Treeview to all lines.
- Select the upper horizontal line representing the edge of the plate and assign the line mesh dataset **Division=8** from the  Treeview. This will overwrite the previous assignment.
- Select the line on the right hand side of the model and assign **Divisions=2** from the  Treeview. This will overwrite the previous assignment.

The surface will now be swept through the depth of the plate to create a volume. Lines on the newly created surface on the back face of the volume will automatically inherit the line mesh dataset from the swept surface. The lines through the depth will however adopt the default number of mesh divisions. Since one element only is required through the depth of the plate the default number of mesh divisions must be set to one.

- Select the **Meshing** tab.
- Change the default number of mesh divisions to **1** and click **OK**

Now the volume that represents a quarter of the plate can be created.

- Select the Surface (use the **Ctrl** and **A** keys together to select whole model).

 Sweep the surface to form a volume.

- Enter a translation in the Z direction of **1** and click the **OK** button.

 Rotate the model to an isometric view to see the volume created.

Now we assign a mesh to the volume. Because it is not a regular volume, a transition mesh is required.

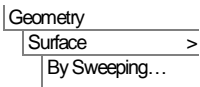
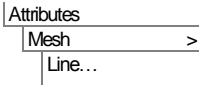

- Double click on the mesh dataset **Composite Brick (HX16L)** and select the **Allow transition pattern** option.



Note. Transition meshing is required to enable the five sided surface to be modelled predominantly with quadrilaterals. When using transitional meshing Modeller will introduce compatible triangular elements as necessary.

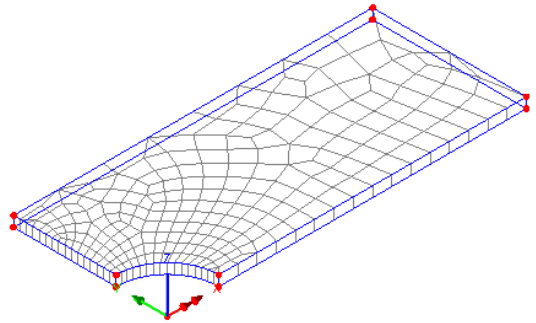

- Click **OK** to change the mesh dataset.
- Use the **Ctrl** and **A** keys to select the whole model and assign the mesh dataset **Composite Brick (HX16L)**
- Click on **Z: N/A** to return the model to the default view from the Z axis.

Material Properties

Properties of a number of the more commonly used composite materials are available from the composite library. The plate in this example is made up from a four layer stack of IM Carbon UD.

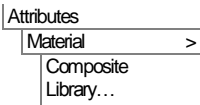

- Select the material **IM Carbon UD Vf=60%** from the drop down list.
- Ensure the option for **3D Solid** is chosen.
- Select the option to output parameters for the **Hashin damage model**
- Click the **OK** button to add the selected composite material properties to the  Treeview.

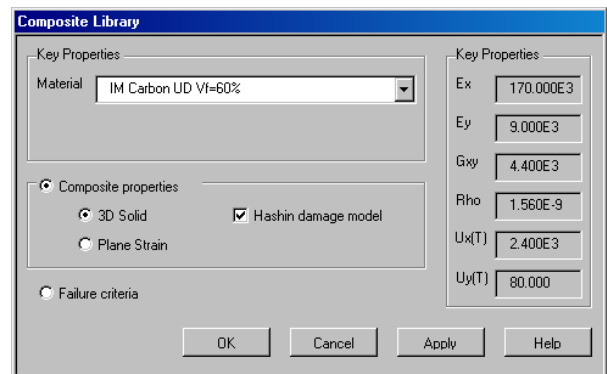

Defining the Composite Stack

- Select the **Solids and Shells** option and click **Next**

Damage Analysis of a Composite Plate

- Select the **New** button

The Add Lamina dialog will appear.

The Name for the first lamina will be automatically entered as **Lamina1**

The material will automatically be entered as **IM Carbon UD Vf=60% (Damage) (N,mm,t,s,C)**

- Leave the thickness as **1** and the angle as **0**

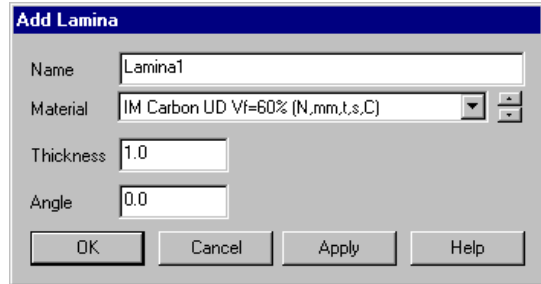

- Click the **OK** button to define the lamina and return to the main dialog.
- Select the **New** button again to define lamina 2
- **Lamina2** will be automatically entered for the lamina name
- Leave the thickness as **1** but change the angle to **90**
- Ensure that material dataset **IM Carbon UD Vf=60% (Damage) (N mm t s C)** is selected.
- Click the **OK** button.
- Select the **Symmetric** button to generate a four layer stack.
- Enter the dataset name as **Laminate Stack** and click the **Finish** button.



Note. The lamina thickness values to be entered for solid models comprised of Pentahedral or Hexahedral composite elements are relative values, not absolute real thicknesses, and represent the proportion of the total thickness (as specified by geometric properties) apportioned to each lamina. In other words, for solid models comprised of Pentahedral or Hexahedral composite elements the sum of all the specified lamina thicknesses will always occupy the geometric thickness defined.

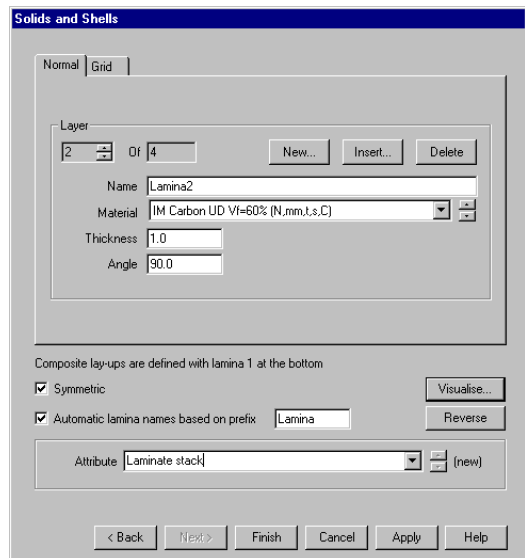

Assigning the Composite Stack

The composite stack now needs to be assigned to the volume so that the zero fibre directions run along the length of the plate. To do this, a local coordinate system is defined such that the local axes defined correspond to the global axes. The composite stack is then assigned relative to this local coordinate system.



Attributes

Local Coordinates...

- Ensure a Rotate Angle of **0** about the **Z-axis** is set. Enter the dataset name as **Global** and click the **OK** button.
- Use **Ctrl** and **A** keys together to select the whole model and from the  Treeview drag and drop the composite dataset **Laminate Stack** onto the selected features.
- On the Assign Composite dialog ensure **Assign to Volumes** is selected. Select the **Local Coordinate** option, ensure the dataset **Global** appears in the drop down list and click the **OK** button.

Visualising lamina directions

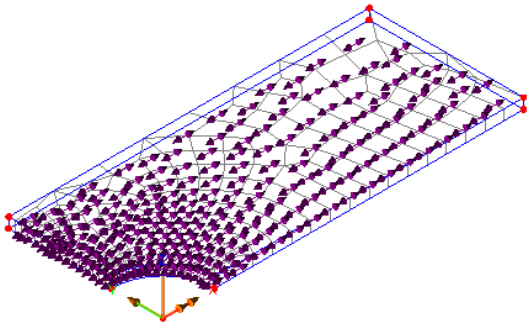
Now the laminate stack is assigned to the model the lamina orientation can be checked by visualising the lamina directions.

- In the  Treeview click on **Attributes** with the right hand mouse button and select **Properties**
 - Select the **Composite** tab, then select the **All** datasets option.
 - Click on the **Settings** button.
 - On the Visualisation Settings dialog select the **Visualise ply directions** option and ensure Surface position **Middle** and Axis **x** are selected.
 - Click the **OK** button to return to the Attribute properties.
 - Click the **OK** button to visualise the layer directions.
- 
- In the  Treeview, in the Composite Laminate Stack section right-click on **Lamina 2** and select the **Set Lamina Active** option.
 - Other lamina directions may be checked by setting each lamina active in turn.



- Turn off visualisation of ply directions by going to the  Treeview clicking on **Laminate stack** with the right hand mouse button and de-selecting **Visualise assignments**.

Supports

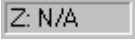
Symmetry supports need to be assigned to the lines of symmetry of the model. This is best done by viewing the plate from above.

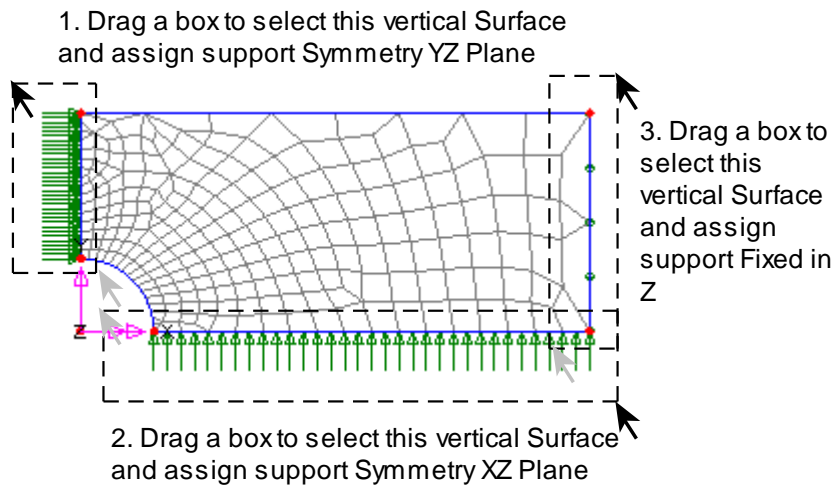
- Click on  to return the model to the default view from the Z axis.



- Drag a box around the Surface on the vertical axis of symmetry.
- Drag and drop the support dataset **Symmetry YZ** from the  Treeview.
- Ensure the **Assign to surfaces** option is selected and click **OK** to assign the support dataset.
- Similarly drag a box around the Surface on the horizontal axis of symmetry and assign the support dataset **Symmetry XZ** from the  Treeview to it.

The model also needs to be restrained from moving in the out of plane direction.

- Drag a box around the Surface on the right hand side of the model and assign the support dataset **Fixed in Z** from the  Treeview.

Loading

The plate is to be placed under a tensile loading using a prescribed displacement.

Attributes
Loading... >

- Select the **Prescribed Displacement** option and click **Next**
- Enter a **Total** displacement of **0.1** in the X direction.
- Enter a dataset name of **Prescribed Displacement** and click the **Finish** button.
- Drag a box around the Surface defining the right hand end of the plate and assign the dataset **Prescribed Displacement** from the  Treeview.
- Click **OK** to assign to **Loadcase 1** with a factor of **1**



Select the isometric view button and check the supports and loading have been applied as shown in this image.

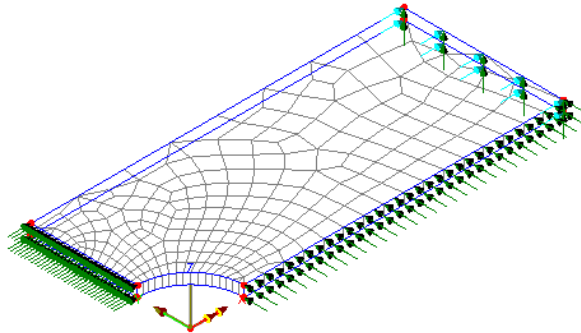

Analysis Control

Because this is a nonlinear problem the load incrementation strategy needs to be defined.

- From the  Treeview right-click on **Loadcase 1** and from the **Controls** option select the **Nonlinear & Transient** option.

The Nonlinear & Transient dialog will appear.

- Select the **Nonlinear** option.
- Set Incrementation to **Automatic**
- Set the Starting load factor to **0.5**
- Set the Maximum change in load factor to **0.25**

Damage Analysis of a Composite Plate

- Set the Maximum total load factor as **1**
- Change the Incremental displacement norm to **100** as convergence is to be monitored on the residual norm only.
- Leave the Maximum number of time steps or increments as **0** as this ensures the solution will continue until the maximum load is reached.

Nonlinear & Transient

Incrementation

Nonlinear

Incrementation: Automatic

Starting load factor: 0.5

Max change in load factor: 0.25

Max total load factor: 1.0

Adjust load based on convergence

Iterations per increment: 4

Solution strategy

Same as previous loadcase

Max number of iterations: 12

Residual force norm: 0.1

Incremental displacement norm: 100.0

Time domain

Time domain

Initial time step: Consolidation

Initial time step: 0.0

Total response time: 100.0E6

Automatic time stepping

Incremental LUSAS file output

Same as previous loadcase

Output file: 1

Plot file: 1

Restart file: 0

Max number of saved restarts: 0

Log file: 1

History file: 1

Common to all

Max time steps or increments: 0

OK Cancel Help

- Click the **OK** button to finish.

To avoid mechanisms in the element formulation when some of the Gauss integration points fail, it is necessary to switch on fine integration for the elements.

- Select the **Solution** tab and click on the **Element Options** button. Ensure that **Fine integration for stiffness and mass** is selected and click **OK**. Click **OK** to finish.

Saving the model



Save the model file.

File
Model Properties...

File
Save

Running the Analysis

File
LUSAS Datafile..



A LUSAS data file name of **composite_plate** will be automatically entered in the File name field.

- Ensure that the options **Solve now** and **Load results** are selected.
- Click the **Save** button to solve the problem.



Note. In running this nonlinear analysis a number of load increments are evaluated. An indication of the time remaining can be obtained by observing the number of the increment being evaluated.

A LUSAS Datafile will be created from the model information. The LUSAS Solver uses this datafile to perform the analysis.

If the analysis is successful...

The LUSAS results file will be added to  Treeview.

In addition, 2 files will be created in the directory where the model file resides:



- composite_plate.out** this output file contains details of model data, assigned attributes and selected statistics of the analysis.
- composite_plate.mys** this is the LUSAS results file which is loaded automatically into the Treeview to allow results processing to take place.

If the analysis fails...

If the analysis fails, information relating to the nature of the error encountered can be written to an output file in addition to the text output window. Any errors listed in the text output window should be corrected in LUSAS Modeller before saving the model and re-running the analysis.

Rebuilding a Model

If it proves impossible for you to correct the errors reported a file is provided to enable you to re-create the model from scratch and run an analysis successfully.



- composite_plate_modelling.vbs** carries out the modelling of the example.

File
New...



Start a new model file. If an existing model is open Modeller will prompt for unsaved data to be saved before opening the new file.

- Enter the file name as **composite_plate** and click **OK**

To recreate the model, select the file **composite_plate_modelling.vbs** located in the **\<LUSAS Installation Folder>\Examples\Modeller** directory.



Rerun the analysis to generate the results

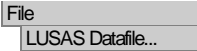
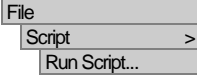

Viewing the Results

Loadcase results for each increment can be seen in the Treeview. If the analysis was run from within LUSAS Modeller the results will be loaded on top of the current model and the loadcase results for the first load increment are set active by default.



If necessary, select the isometric view button.

- If present, turn off the **Geometry** and **Attributes** layers in the Treeview.

Stress Contours

- In the Treeview, right-click on the final load increment for **Increment 3 Load Factor = 1** and select the **Set Active** option.

For solid models the lamina results can be selected for the top, middle or the bottom of any selected lamina. For this example the middle of selected laminae will be viewed. By default LUSAS will automatically transform results into the material direction.

- With no features selected click the right-hand mouse button in a blank part of the graphics window and select **Contours** to add the contours layer to the Treeview.

The contour Properties dialog will be displayed.

- Select entity results of **Stress - Solids lamina (middle)** of component **Sx** and click the **OK** button.
- In the Treeview expand the Composite Strip layout entry and right-click on the **Lamina1** and **Set Lamina Active**

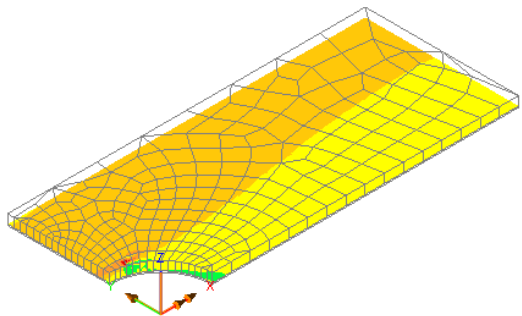

The contour key should be showing a maximum stress in the lamina X material direction of 1.8E3

- By re-ordering the layers in the  Treeview the mesh can be viewed on top of the contour results.



Note. When displaying layer contours the contours are displayed at the layer position through the thickness of the model.

- In the  Treeview, in the Composite Laminate Stack entry, right-click on **Lamina2** and **Set Lamina Active**

The contour key should be showing a maximum stress in the lamina X material direction of 1.6e3

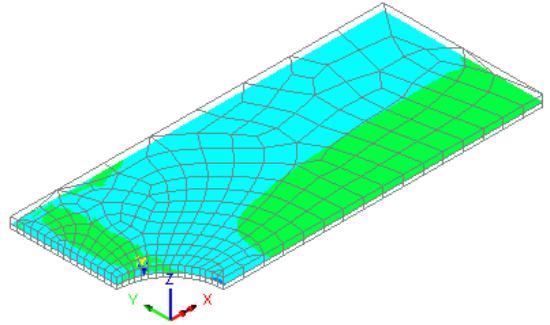

Failure Contours

When using the Hashin failure model the failure indicator (IFFLR) can be contoured. The indicator has the following values:

Indicator (IFFLR)	Description
0-1	No failure
1-2	Matrix failure
2-3	Fibre failure
3+	Matrix and fibre failure

To display contours of the failure index for layer 2:

- Double-click the **Contours** layer name in the  Treeview.

The contour Properties dialog will be displayed.

- Select entity results of **Stress - Solids lamina (middle)** of component **IFFLR**.
- Select the **Contour Range** tab
- Set the contour interval to 1
- Set the maximum contour value to 3

Damage Analysis of a Composite Plate

- Set the minimum contour value to 1
- Click **OK** to display contours of Hashin failure in the material fibre direction for Lamina 2.

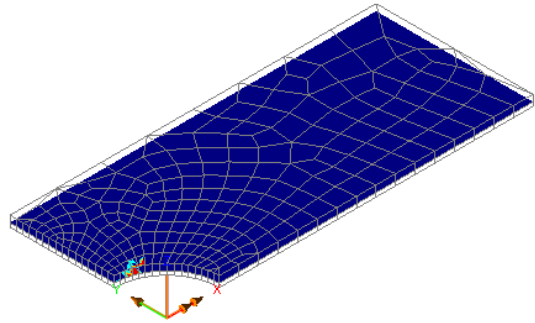

- By zooming in the region of failure can be seen in more detail.

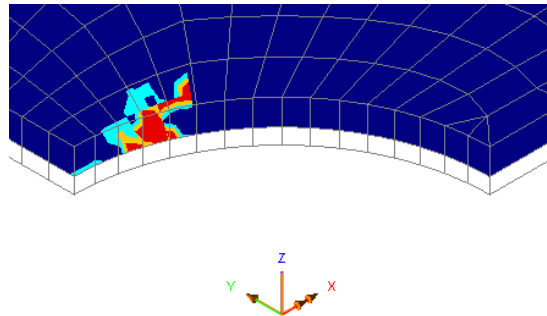

- By changing the active loadcase it can be seen that no failure has occurred after the first load increment (a load factor of 0.5). By the second load increment (a load factor of 0.75) a small amount of matrix failure has occurred adjacent to the hole.

This completes this example.

Mixed-Mode Delamination

For software product(s):	Any Plus version.
With product option(s):	Nonlinear.
Note: The example exceeds the limits of the LUSAS Teaching and Training Version.	

Description

This example demonstrates the use of delamination elements in a 2D analysis. Both 2D and 3D delamination elements are available within LUSAS. These elements have the ability to model all modes of crack growth under mixed-mode conditions - mode I (open) mode II (shear) and mode III (tear 3D only).

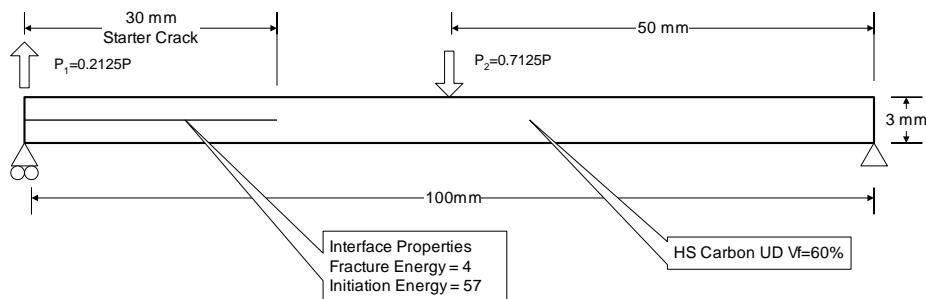

The model is required to predict the growth of a crack within a unidirectional composite laminate subjected to mixed-mode loading. A starter crack 30 mm long is introduced at one end of a double cantilever beam (DCB) specimen. A tensile (crack opening) load is applied to the cracked end of the sample while a compressive (crack closing) load is applied to the centre of the specimen. The resulting delamination crack propagates along the length of the sample under mixed-mode conditions.

The DCB specimen is constrained at either end and prescribed displacements are applied to the centre of the span in a negative Y direction and to the cracked arm, in a

positive Y direction. No axes of symmetry other than the plane strain assumption may be made. The geometry of the strip and support positions are as shown.

Units of N, mm, t, s, C are used throughout.

Objectives

This analysis will:

- Predict the initiation of delamination
- Predict the propagation of a delamination crack with increasing displacement
- Produce an animated Deformed Mesh Plot showing the growth of delamination
- Produce a Contour Plot showing the redistribution of direct stress caused by delamination on the cracked Surface.
- Produce an animated Yield Plot showing the behaviour of the interface during incrementation

Keywords

Delamination, Composite, Shell, Nonlinear, Yield Symbol, Contour Plot, Animation

Associated Files



- delamination_modelling.vbs** carries out the complete modelling of the example.

Modelling : Delamination Model

Running LUSAS Modeller

For details of how to run LUSAS Modeller see the heading *Running LUSAS Modeller* in the Examples Manual Introduction.



Note. This example is written assuming a new LUSAS Modeller session has been started. If continuing from an existing Modeller session select the menu command **File>New** to start a new model file. Modeller will prompt for any unsaved data and display the New Model dialog.

Creating a new model

- Enter the file name as **delamination**
- Use the **Default** working folder.
- Enter the title as **Delamination Model**

- Set the units to **N,mm,t,s,C**
- Select the **Structural** User Interface.
- Select the startup template **Composites**
- Select the **Vertical Y axis** option.
- Click the **OK** button.



Note. It is useful to save the model regularly as the example progresses. Use the Undo button to correct any mistakes made since the last save was done.



- Select the **Meshing** tab and set the default number of divisions to **2**
- Select the **Solution** tab, select **Element Options** and select the option for **Fine integration for stiffness and mass**
- Click the **OK** button to set the element options and the **OK** button to set the model properties.

Defining the Geometry

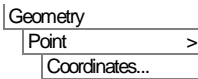

Enter coordinates of **(0,0)**, **(30,0)**, **(50,0)** and **(100,0)** and click **OK** to define the Points.

- Use the **Ctrl** and **A** keys together to select the Points just defined.

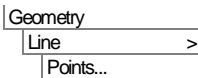

Defines a series of straight Lines between the Points.

- Select the whole model using the **Ctrl** + **A** keys together.

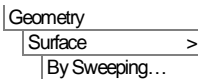

Ensure that the **Translate** option is selected and enter a value of **1.5** in the **Y** direction.

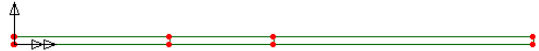

- Click the **OK** button to finish to generate the first half of the model.

The second half of the model will now be created by copying the existing data and specifying a suitable gap to enable the interface elements to be embedded in the model. Once the interface elements have been assigned this gap will be closed.

- Select the whole model using the **Ctrl** + **A** keys.

Mixed-Mode Delamination

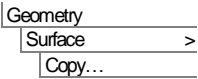

Ensure that the **Translate** option is selected and enter a value of **20** in the **Y** direction.





Note. At this stage the two halves of the model are separated to simplify the definition of the delamination interface elements.

Meshing

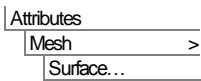

Delamination modelling requires a fine mesh density. The mesh density is controlled using Line mesh attributes.

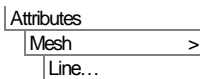

- Select **Plane strain**, **Quadrilateral**, **Quadratic** elements. Ensure the **Regular mesh** option is selected with automatic divisions so that Modeller uses the default number of mesh divisions on each line.
- Give the attribute the name **Plane Strain Mesh**
- Click the **OK** button to add the attribute to the  Treeview.
- Select the whole model using the **Ctrl + A** keys.
- Drag and drop the **Plane Strain Mesh** attribute from the  Treeview onto the selected features.

The  Treeview contains some commonly used line meshes. Null line meshes with 10 and 30 divisions need to be added to those present.



- With the Element description set to **None** define a line mesh attribute containing **10** divisions and named **Divisions=10**
- Click the **Apply** button to add the attribute to the  Treeview.
- Edit the number of divisions to **30** and change the attribute name to **Divisions=30**
- Click the **OK** button to add the attribute to the  Treeview.
- Assign the **Divisions=10** attribute to the horizontal lines on the left-hand section of the model.

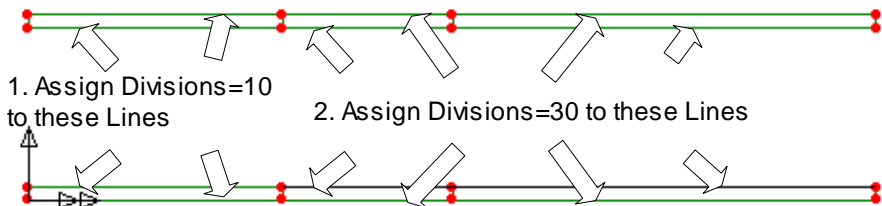

- Assign the **Divisions = 30** attribute to the remaining horizontal lines of the rest of the model to give a mesh arrangement as shown.

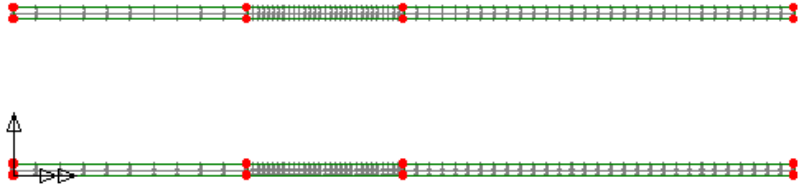

Geometric Properties

Because this model is using plane strain elements there is no need to define or assign a geometric thickness to the model. Plain strain elements assume infinite thickness.

Interface Elements

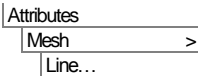

- On the Line Mesh dialog define an **Interface, 2-dimensional, Quadratic** line mesh with **30** divisions.
- Name the dataset **Interface mesh**
- Click **OK** to add the dataset to the Treeview.
- Select the two horizontal lines on the right-hand side of the upper face of the bottom set of surfaces as shown in the following diagram.

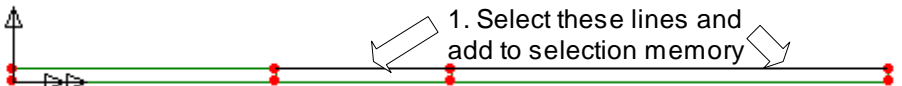

- Add these two lines to Selection Memory. These will form the slave surfaces of the interface elements.

Mixed-Mode Delamination



Note. Items can also be added to selection memory by using the right-hand mouse button in the display area and selecting the **Selection Memory>Set** menu entry from the popup menu.



Note. The order in which the lines are selected is important. The interface elements are drawn between sequential pairs of lines in the two selections, i.e. the first set will be drawn between the first line in the selection memory and the first line in the selection.

- Click in a blank area to deselect the initial selection (note that the lines in selection memory will remain highlighted)

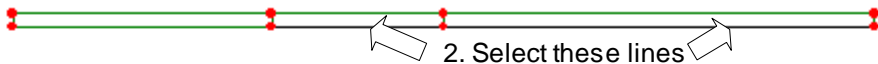

- Select the two horizontal lines on the right-hand side of the lower face of the top set of surfaces as shown in the previous diagram. Ensure the lines in the selection match those in selection memory as described in the note above.
- Drag and drop the **Interface mesh** attribute onto the model. Ensure **Mesh from**

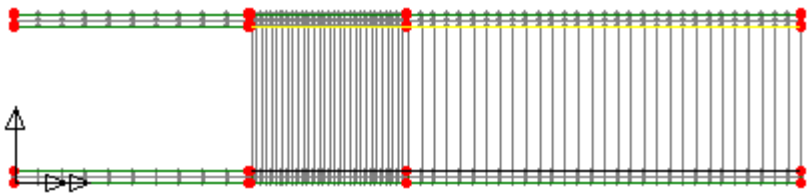

master to slave is selected. Click **OK** to finish the assignment.

- Clear the selection memory.





Note. It is only necessary to make use of Selection Memory if assignment of the interface mesh is to be carried out on more than one line in one operation. By selecting a lower master line, holding the Shift key down, and selecting the

corresponding upper slave line the assignment could also be carried out on a line by line basis.

Composite Material

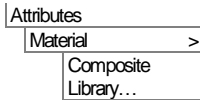
LUSAS provides a number of the more common types of composite material in the Composite Material Library. In this example the component is fabricated from a unidirectional High Strength Carbon fibre reinforced polymer matrix composite.



- Select **HS Carbon UD Vf=60%** from the drop down box.
- With the **Composite properties** option selected, choose **Plane Strain** and click the **OK** button to add the properties to the  Treeview.

The composite material is assigned to the surfaces of the model. Firstly check the surface axes to show the directions for the orthogonal material.

- In the  Treeview click the right-hand mouse button on the **Geometry** layer and select **Properties**
- On the dialog select the **Surface Axes** option and click the **OK** button. All surfaces should appear with the double arrow (X direction) horizontal.
- De-select the display of Surface axes as described above.

Now assign the material properties:

- Select the whole model using the **Ctrl + A** keys.
- Select the **HS Carbon UD Vf=60% Plane Strain (N,mm,t,s,C)** attribute from the  Treeview and drag and drop it onto the model.
- Ensure the **Assign to surfaces** option is selected on the pop up dialog and click **OK**

Interface Material

Information concerning the fracture energies and the initiation stresses for the relevant failure modes are defined to describe the behaviour of the interface delamination model. For this example it is assumed that the interface characteristics are similar for the two modes. Mode 1 representing opening and mode 2 shear.



- Ensure the number of fracture modes equals **2** (default)
- Enter the value **4** for the fracture energy and **57** for the initiation stress for both modes.

Mixed-Mode Delamination

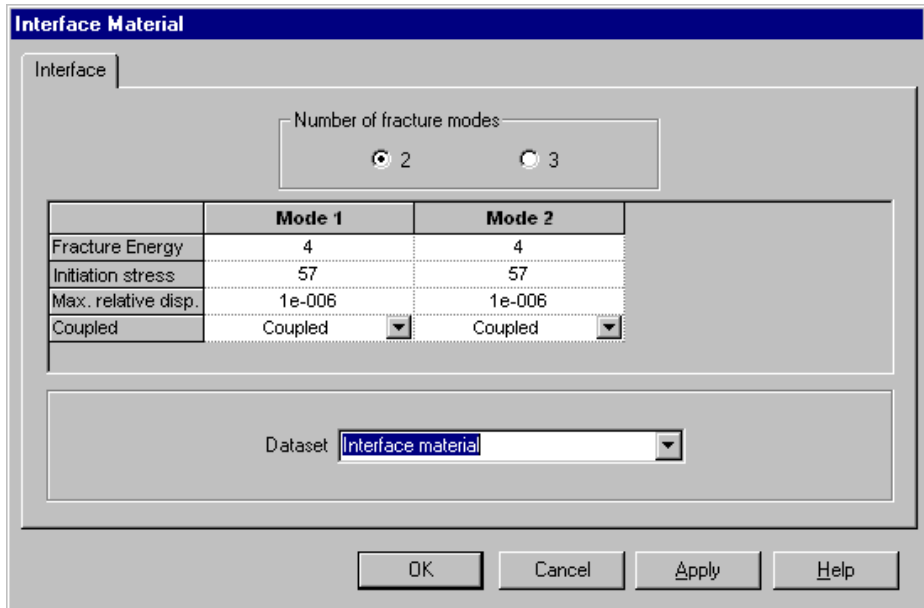

- Name the attribute **Interface Material** and click on **OK** to add the attribute to the  Treeview.



	Mode 1	Mode 2
Fracture Energy	4	4
Initiation stress	57	57
Max. relative disp.	1e-006	1e-006
Coupled	Coupled	Coupled



Note. The interface material attribute need only be assigned to the master features.

- Click the right-hand mouse button on the **Interface Mesh** attribute in the  Treeview and choose the **Select Master Assignments** option from the drop down menu.
- Drag and drop the **Interface Material** attribute from the  Treeview onto the model to assign to Lines.

Supports

LUSAS provides the more common types of support by default. These can be seen in the  Treeview. The model will be supported in the Y direction at the cracked (left-hand) end and in the X and Y directions at the uncracked (right-hand) end.

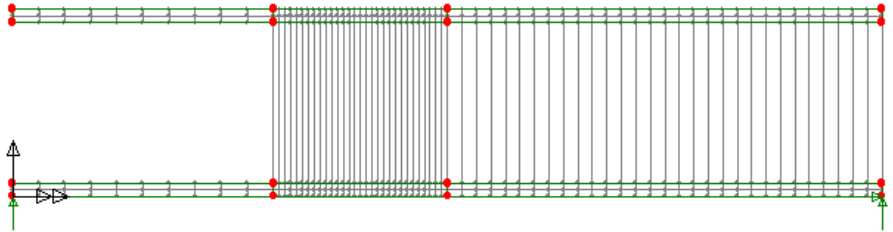

- Select the point at the bottom left-hand corner of the model, drag and drop the support attribute **Fixed in Y** onto the selection and click **OK** to assign to Points.
- Select the point at the bottom right-hand corner of the model, drag and drop the support attribute **Fixed in XY** onto the selection and click **OK** to assign to Points.

The supports will be visualised as shown.

Loading

The model is subjected to two prescribed displacements. The left-hand (cracked) end of the model has a crack opening load assigned to it. A crack closing load is assigned to the mid-span.

Attributes

Loading...

The structural Loading attributes dialog will be displayed.

- With the **Concentrated** option selected click **Next**
- On the Concentrated dialog enter a **Concentrated load in Y Dir** of **0.2125**
- Enter the attribute name as **Opening**
- Click the **Apply** button to add the attribute to the Treeview.
- Edit the value in the **Y** direction to be **-0.7125**
- Enter the attribute name as **Closing**
- Click the **Finish** button to add the loading attribute to the Treeview.

Now assign the loads to the model.

- Select the uppermost Point in the top left-hand corner of the model. (See following diagram)
- Drag and drop the loading attribute **Opening** from the Treeview onto the selected Point.

Mixed-Mode Delamination

- Click the **OK** button to accept the default **Loadcase 1** with a Load factor of **1** and assign the loading to the model.

Select this Point to assign Opening load

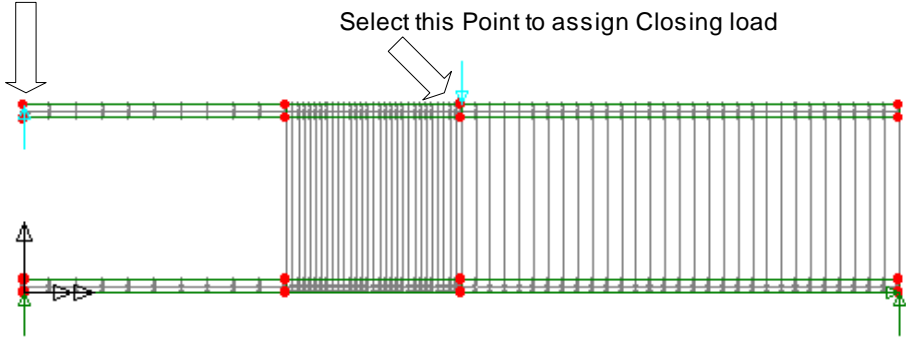

- Select the uppermost Point in the middle of the top section of the model.
- Drag and drop the loading dataset **Closing** from the  Treeview onto the selected Point.
- Click the **OK** button to accept the default **Loadcase 1** with a Load factor of **1** and assign the loading to the model.

The loading will be visualised.

Final Geometry Manipulation

It is significantly easier to assign the appropriate mesh and the material properties of the interface region to the model if the interface surfaces are apart. Once these manipulations are complete it only remains to close the interface to complete the construction of the model.

- Select the top section of the model.

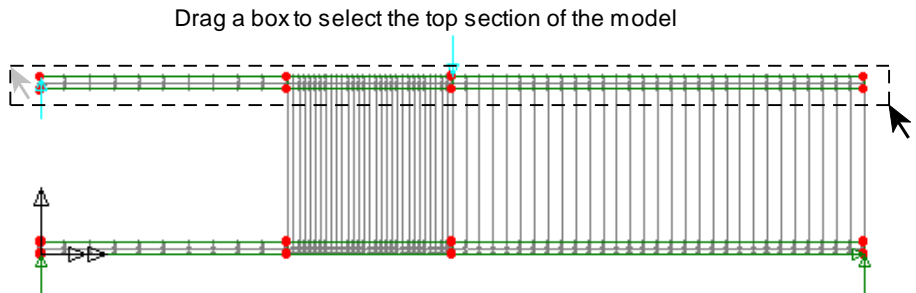

Geometry
 Point >
 Make Unmergable

Make the points of the upper section unmergable. This will ensure the nodes either side of the embedded crack in the model are not merged together. Note that making points unmergable will also ensure that the lines are also unmergable

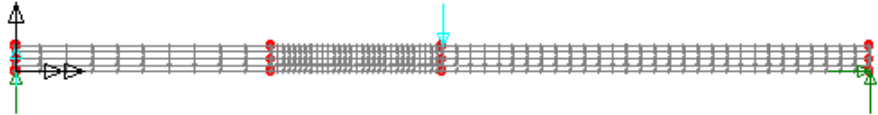

Geometry
 Point >
 Move...



Move the selection to join the bottom half of the model by selecting the **Translate** option, enter a value of **-18.5** in the **Y** direction and click **OK** to confirm.

Analysis Control

Since this is a nonlinear problem the load incrementation strategy needs to be defined. The analysis is to be terminated when the vertical displacement at the left-hand tip of the specimen reaches 6mm.

- Select the point at the top-left of the model where the opening load is applied.
- From the  Treeview click the right hand mouse button on **Loadcase 1** and select **Nonlinear & Transient** from the **Controls** menu.

The Nonlinear & Transient dialog will be displayed.

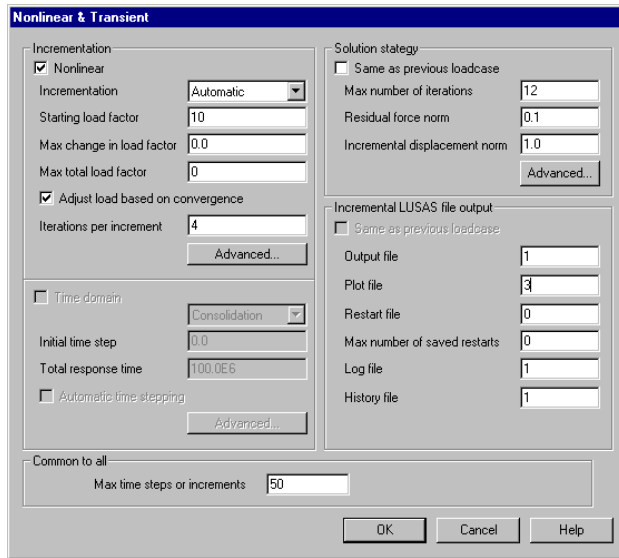

- Select the **Nonlinear** option.
- Set Incrementation to **Automatic**
- Set the Starting load factor to **10**. This will multiply the applied loading by a factor of 10 on the first load increment.
- To enable the load to increase as required set the Max total load factor to **0**
- To prevent the analysis carrying on too long if an error has been made set the maximum number of time step or increments to **50**
- In the Incremental LUSAS file output section set the Plot file value to **3**. This will ensure results are output to the Modeller plot file every third load increment.
- In the Incrementation section on the top-left of the dialog select the **Advanced** button.
- Select **Use arc length control**
- Select the option to **Use root with lowest residual norm**
- In the Termination criteria section select the **Terminate on value of limiting variable** option. The point at the top left-hand corner of the model should be entered in the drop down list. Note that this may not be the same point number as shown in this dialog.
- Select the Variable type as **V** and the value as **6**

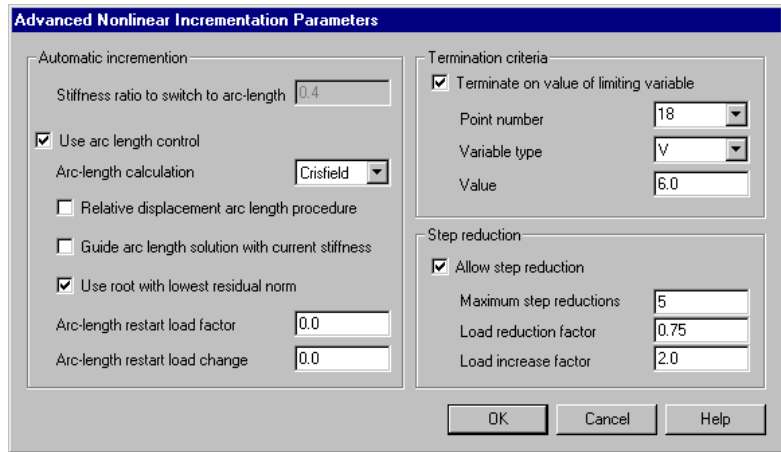

- In the Step reduction section of the form ensure the **Allow step reduction** option is selected and set the Load reduction factor to **0.75**
- Click the **OK** button to return to the control dialog.
- Click the **OK** button to exit the Nonlinear & Transient dialog.

A Nonlinear and Transient entry will be added to the Treeview . A separate Nonlinear analysis options entry will also be added to the loadcase.

Defining a Geometric Nonlinear analysis

One additional setting is required to allow a geometric nonlinear analysis to take place.

- Double-click on the **Nonlinear analysis options** object in the Treeview.
- Select the **Updated Lagrangian** option and click **OK**.



Note. The Nonlinear analysis options object sets parameters for the whole analysis and the Nonlinear and Transient object sets control properties for each loadcase.

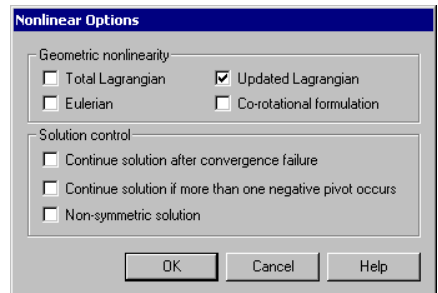

Saving the model

The model is now complete and the model data must be saved.

File
Save



Save the model file.

Running the Analysis

With the model loaded:

File
LUSAS Datafile...



A LUSAS data file name of **delamination** will be automatically entered in the File name field.

- Ensure **Solve now** and **Load results** are selected.
- Click the **Save** button to finish.



Note. In running this nonlinear analysis a number of load increments are evaluated. On modern personal computers this will take just a minute or so. An indication of the time remaining can be obtained by observing the number of the increment being evaluated.

A LUSAS Datafile will be created from the model information. The LUSAS Solver uses this datafile to perform the analysis.

If the analysis is successful...

The LUSAS results file will be added to the  Treeview.

In addition, 2 files will be created in the directory where the model file resides:



- delamination.out** this output file contains details of model data, assigned attributes and selected statistics of the analysis.
- delamination.mys** this is the LUSAS results file which is loaded automatically into the  Treeview to allow results processing to take place.

If the analysis fails...

If the analysis fails, information relating to the nature of the error encountered can be written to an output file in addition to the text output window. Any errors listed in the text output window should be corrected in LUSAS Modeller before saving the model and re-running the analysis.

Rebuilding a Model

If it proves impossible for you to correct the errors reported a file is provided to enable you to re-create the model from scratch and run an analysis successfully.



- **delamination_modelling.vbs** carries out the complete modelling of the example.

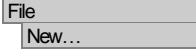

Start a new model file. If an existing model is open Modeller will prompt for unsaved data to be saved before opening the new file.

- Enter the file name as **delamination**

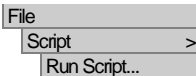

To recreate the model, select the file **delamination_modelling.vbs** located in the `\<LUSAS Installation Folder>\Examples\Modeller` directory.





Rerun the analysis to generate the results

Viewing the Results

Once the model has been successfully run and the results file loaded on top of the of the model file, an examination of the results can begin. The first stage in any results post-processing is to examine the deformed mesh.

Plotting the deformed mesh

The outline of the crack which has been initiated and grown during the solution with load incrementation may be observed using a solid representation of the model. For this the deformed mesh will be examined alone. All of the model information currently displayed must be removed.

- Turn off each of the layer entries under the  Treeview.
- With no features selected click the right-hand mouse button in a blank part of the graphics area and select **Deformed Mesh**
- Select the **Specify Factor** option and give the value of **1**
- Click on the **Mesh** tab.
- Select the **Solid** and **Outline only** options.
- Click the **OK** button to add the deformed mesh layer to the  Treeview.



Note. It is useful to use a magnification factor for displaying the deformed mesh for nonlinear analyses so that change in shape through the analyses can be observed.

Mixed-Mode Delamination

- Select the last (lowest) available loadcase from the  Treeview and make it active by clicking the right-hand mouse button and choosing the **Set Active** option.

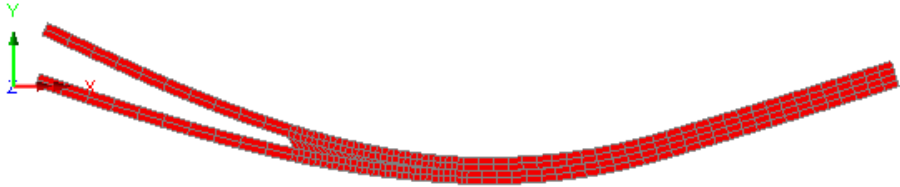

The deformed mesh plot for the final loadcase increment will be displayed.

Plotting the load deflection graph

- **Select the node** at the top left-hand corner of the model where the opening load is applied.
- With **Time history** selected click **Next**
- With the **Nodal** option selected click **Next**
- Select Entity **Displacement** with Component **RSLT**
- The selected node will be visible in the drop down box. Click **Next**
- Select the **Named** option and click **Next**
- From the drop down list pick **Total Load Factor** and click **Next**
- Enter the desired graph titles and click **Finish** to display the load deflection graph.

Utilities

Graph Wizard...

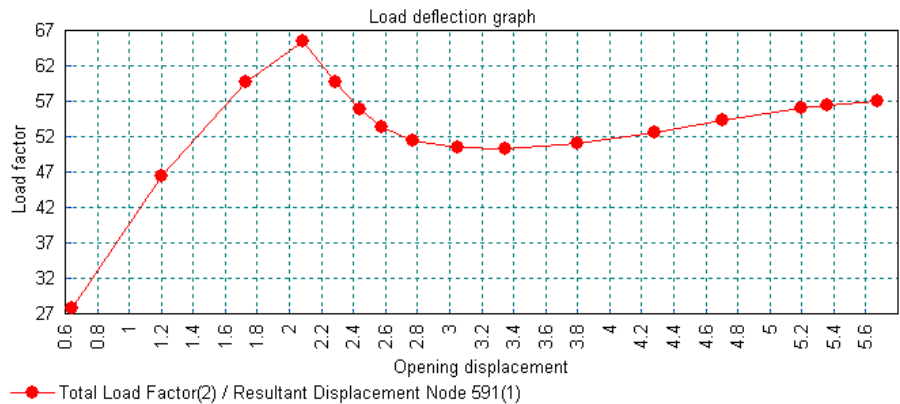

- Close the graph window.

Stress contours

The growth of the delamination seen in the deformed mesh affects the stress distribution within the structure. This stress redistribution is easily visualised using stress contour plots.

- With no features selected click the right-hand mouse button in a blank part of the Graphics area and select **Contours** to add the Contours layer to the  Treeview.

The Contour Properties dialog will be displayed.

- Select **Stress - Plane Strain** contour results in the direction **SX**
- Click the **OK** button to finish.

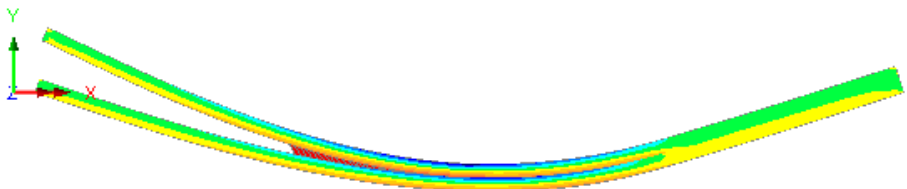

The contour plot and the associated contour key will be displayed.

Animating the effect of delamination growth

By setting other loadcase attributes active the effect of the delamination growth on the stress distribution may be observed. The most effective way to view this effect is to animate the deformed mesh with the stress contours layer showing.

Before animating each loadcase the contour range must be set to avoid the contour key changing between animation frames.

- Double click on the **Contours** layer in the  Treeview.
- Select the **Contour Display** tab.
- Select the **Contour Range** tab.
- Select the **Maximum** and **Minimum** values and insert **1000** and **-1000**
- Select the **Set as global range** option
- Click the **OK** button to finish.

To create the animation

- Select **Load History**
- Select **Next**
- Select **delamination.mys** from the drop-down menu.
- Select the **All Loadcases** check-box.
- Select **Finish** to create an display the animated sequence.

 **Note.** Animations may be saved for replay using other Windows animation players using the **File>Save As AVI** menu option.

 After viewing the animation close the animation window and maximise the graphics window.

Yield Plot

The interface material formulation is an energy based model. The model allows the material to display three zones of behaviour. These are the elastic, softening and failed regions. Yield flags may be used to indicate which nodes within the model (if any) lie within a particular region. This technique allows a precise demonstration of the delamination crack extent within the model.

- Turn off the **Contours** layer in the  Treeview.

Utilities

Animation Wizard...

- With no features selected, click the right hand mouse button in the graphics window and select the **Values** layer from the menu.
- In the **Properties** dialogue box select the entity as **Stress - Interface Elements** and the component **Yield**
- Click **OK** to display the softening zone.

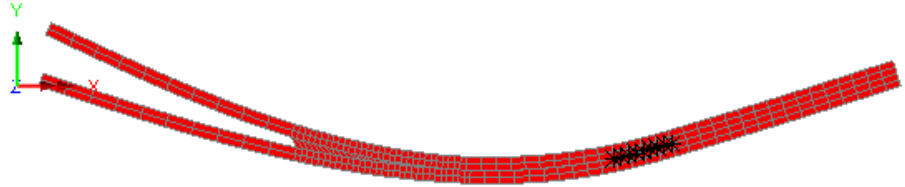

The extent of the delamination for the current loadcase can be clearly seen. The delamination growth can be visualised by animating this plot through successive loadcases.

To create an animation of the delamination growth.

Utilities
Animation Wizard...

- Select **Load History**
- Select **Next**
- Select **delamination.mys** from the drop-down menu.
- Select the **All Loadcases** check-box.
- Select **Finish**

This completes the example.

