

CUSTOMER SUPPORT NOTE

Ensuring Mesh Connectivity in Volume and Surface Models

Note Number: **CSN/LUSAS/1003**

This support note is issued as a guideline only.



Forge House, 66 High Street, Kingston upon Thames, Surrey, KT1 1HN, UK
Tel: +44 (0)20 8541 1999 Fax: +44 (0)20 8549 9399
Email: info@lusas.com www.lusas.com

© Finite Element Analysis Ltd.

Table of Contents

1. INTRODUCTION	2
2. VOLUME MODELS	2
2.1 Description	2
2.2 Example	2
3. SURFACE MODELS	5
3.1 Description	5
3.2 Example	5
4. SUMMARY	8

1. Introduction

Connectivity problems can cause mesh discontinuities, leading to inaccurate models and unreliable results. This technical note explains how to ensure correct connectivity, both between volumes and between surfaces. It should be read alongside the technical note on identifying connectivity issues (CSN/LUSAS/1036).

2. Volume models

2.1 Description

When a surface is shared between two volumes, the volumes are connected at the surface. Assigning a volume mesh attribute to both volumes generates shared nodes, creating a structural (or thermal) connection between them.

2.2 Example

The model in this example consists of two volumes (Figure 1). The top face of the large volume is at the same height as the bottom face of the small volume.

The two volumes are disconnected because they do not share any surfaces. As a result, assigning a volume mesh attribute generates two independent meshes. The mesh is shown in Figure 2, where it is evident that the elements of the large volume do not share nodes with those of the small volume. Consequently, the two volumes are structurally (or thermally) disconnected.

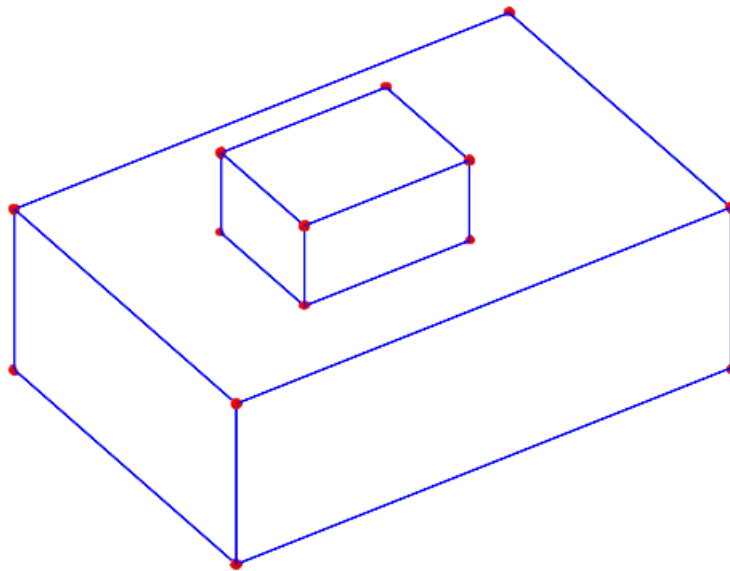

Figure 1 – Two independent volumes: Geometry.

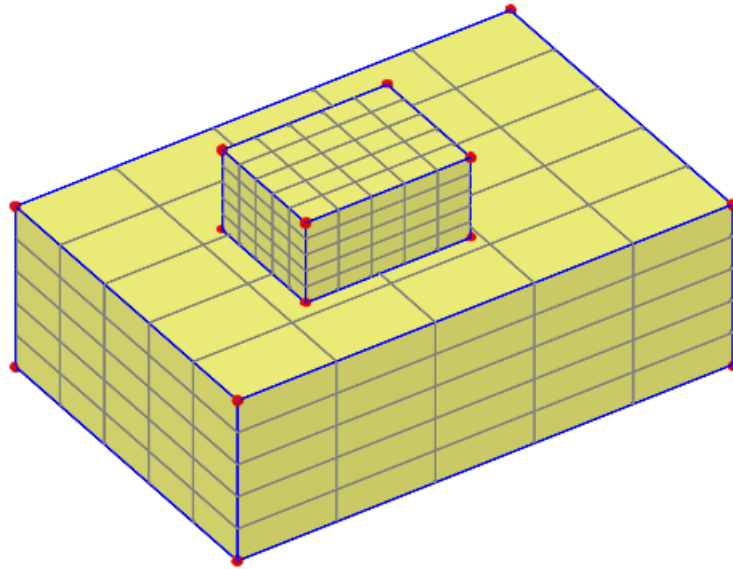

Figure 2 – Two independent volumes: Mesh.

Subdividing the large volume into five volumes, as shown in Figure 3, allows connectivity. Assigning a volume mesh attribute generates the mesh shown in Figure 4. As the volumes are connected, their meshes share nodes. However, some of the resulting elements are not cuboids, which may be undesirable.

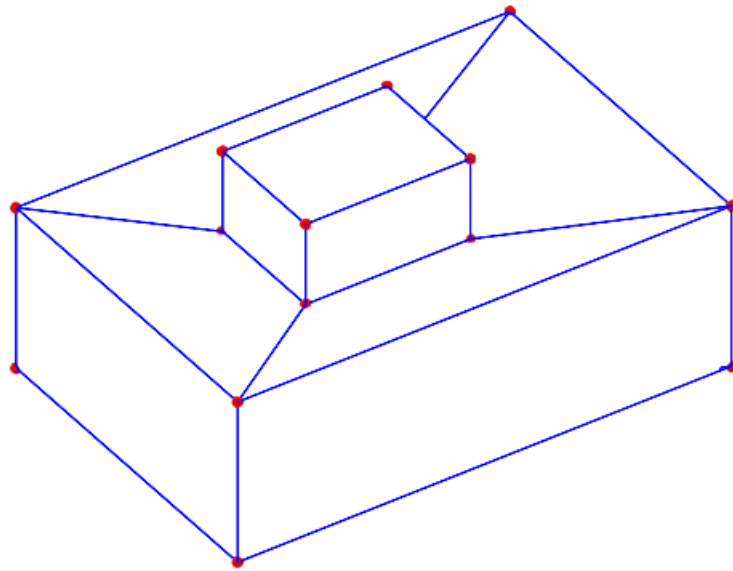

Figure 3 – Large volume subdivided into five volumes: Geometry.

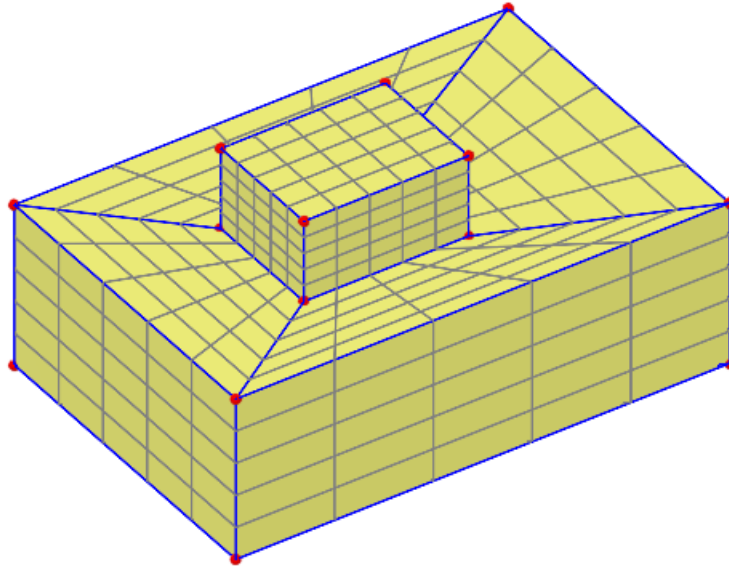

Figure 4 – Large volume subdivided into five volumes: Mesh.

Subdividing the large volume into nine volumes, as shown in Figure 5, also allows connectivity. Assigning a volume mesh attribute generates the regular mesh shown in Figure 6. Since the volumes are connected, their meshes share nodes. In this case, all elements are cuboids.

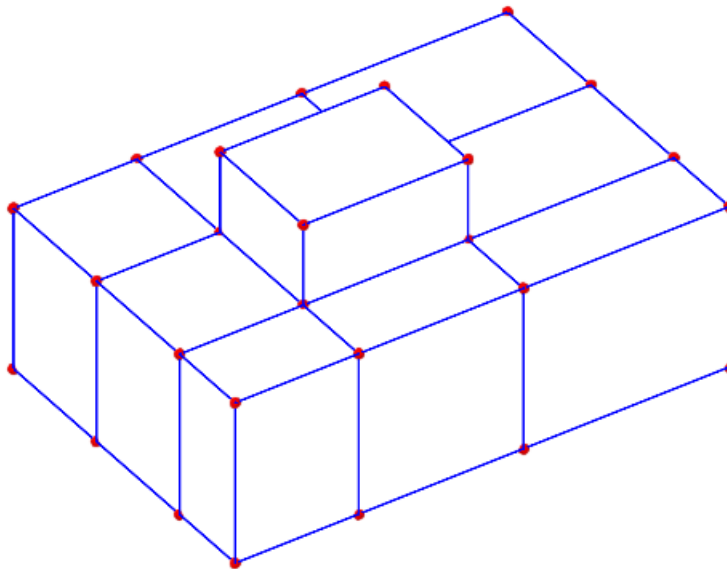

Figure 5 – Large volume subdivided into nine volumes: Geometry.

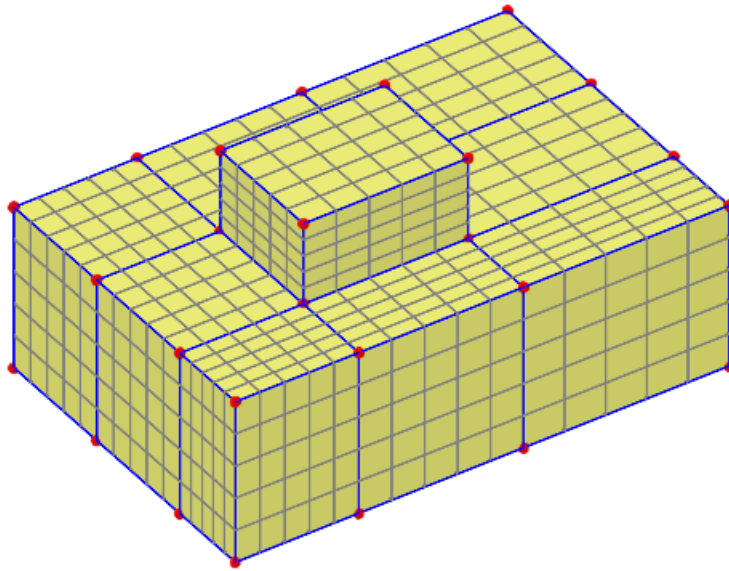

Figure 6 – Large volume subdivided into nine volumes: Mesh.

3. Surface models

3.1 Description

When a line is shared between two surfaces, the surfaces are connected along the line. Assigning a surface mesh attribute to both surfaces generates shared nodes, creating a structural (or thermal) connection between them.

3.2 Example

The model in this example consists of two surfaces (Figure 7). The surfaces do not share any lines. As a result, assigning a surface mesh attribute generates two independent meshes. The mesh is shown in Figure 8, where it is evident that the elements of the large surface do not share nodes with those of the small surface. Consequently, the two surfaces are structurally (or thermally) disconnected.

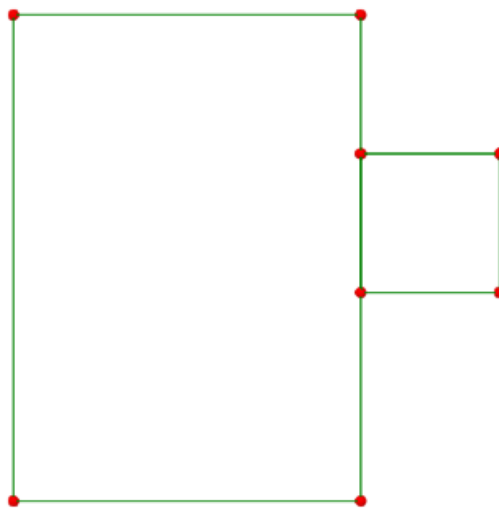

Figure 7 – Two independent surfaces: Geometry.

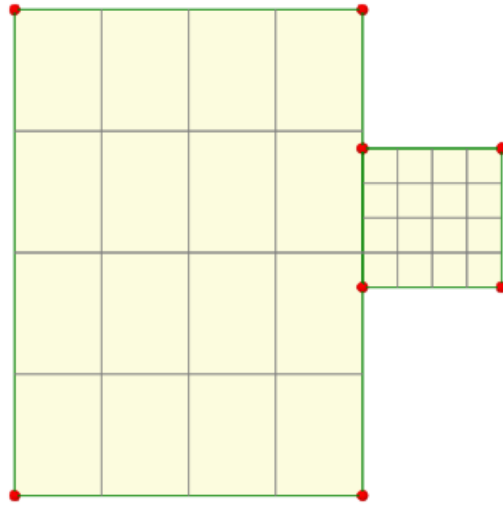

Figure 8 – Two independent surfaces: Mesh.

Subdividing the large surface into three rectangular surfaces, as shown in Figure 9, allows connectivity. Assigning a surface mesh attribute generates the mesh shown in Figure 10. As the surfaces are connected, their meshes share nodes.

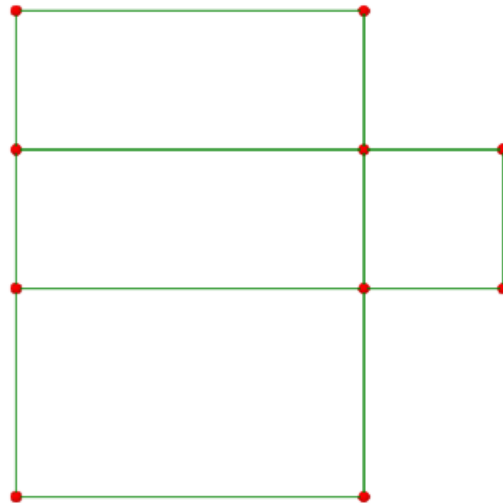

Figure 9 – Large surface subdivided into three surfaces: Geometry.

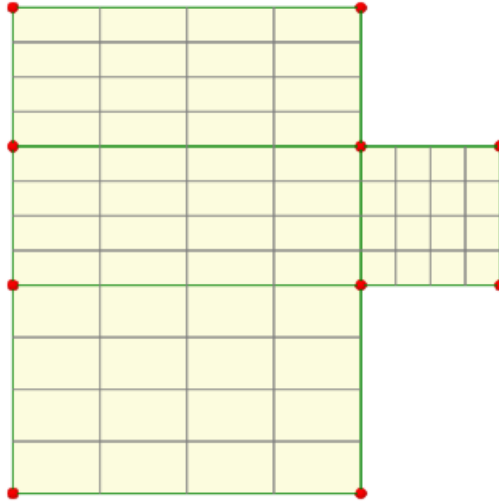

Figure 10 – Large surface subdivided into three surfaces: Mesh.

When there are no overlapping lines, using a combined line can eliminate the need to subdivide the large surface and enables the generation of a well-shaped mesh. The required steps are as follows:

- Ensure that there are no overlapping lines.
- Create a combined line from the orange lines shown in Figure 11.
- Define the large surface using the three pink lines and the combined line.

Assigning a surface mesh attribute generates the mesh shown in Figure 12. Null line mesh attributes, with appropriate divisions, should be used to control the number, size, and shape of the elements.

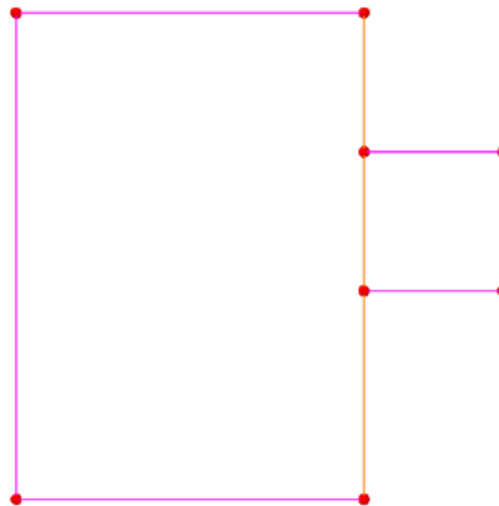

Figure 11 – Large surface defined by three lines and a combined line: Geometry.

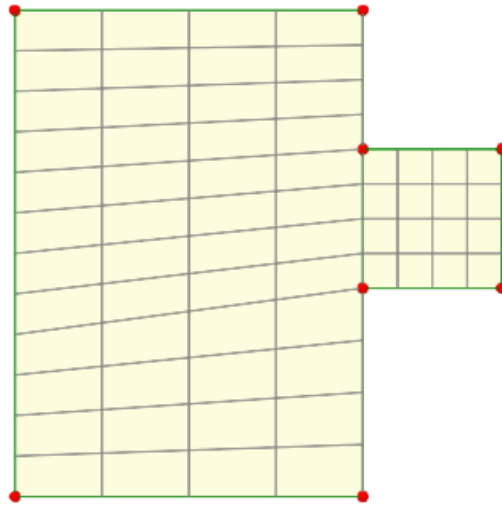

Figure 12 – Large surface defined by three lines and a combined line: Mesh.

Alternatively, the large surface can be defined using the six lines forming its perimeter, without the use of the combined line described above. The resulting mesh, shown in Figure 13, consists of irregularly shaped elements. A comparison between Figure 12 and Figure 13 clearly demonstrates that the use of combined lines can improve mesh quality. This approach is equally effective when applied to volume meshes.

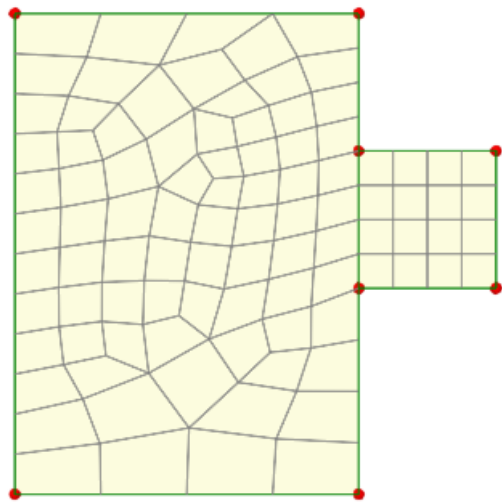

Figure 13 – Large surface defined by six lines: Mesh.

4. Summary

Connectivity problems can cause mesh discontinuities, leading to inaccurate models and unreliable results.

When a surface is shared between two volumes, the volumes are connected at the surface. Assigning a volume mesh attribute to both volumes generates shared nodes, creating a structural (or thermal) connection between them.

When a line is shared between two surfaces, the surfaces are connected along the line. Assigning a surface mesh attribute to both surfaces generates shared nodes, creating a structural (or thermal) connection between them.

If you have any doubts or require specific advice for your type of analysis, please contact the LUSAS Technical Support team at support@lusas.com.