

3-Span Concrete Box Beam Bridge of Varying Section

For LUSAS version:	21.1
For software product(s):	LUSAS Bridge or LUSAS Bridge Plus
With product option(s):	None

Description

A 3-span concrete box beam bridge of varying cross-section is to be modelled to illustrate the use of the box section property calculator and the use of the multiple varying sections facilities in LUSAS.

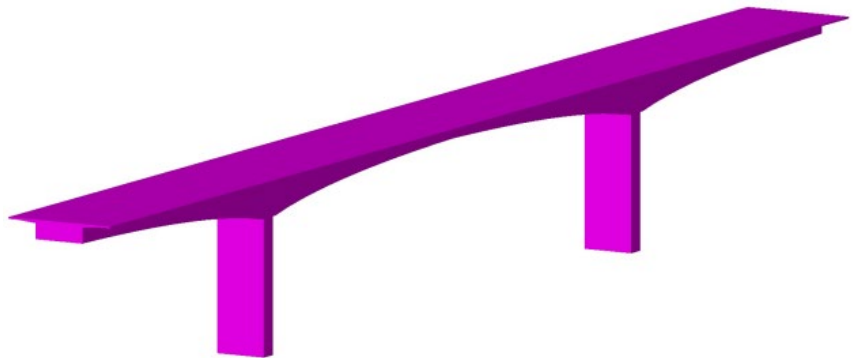

Two models are to be created: a preliminary model suitable for prototype / assessment work and a more detailed model suitable for developing further into a staged construction model. Simplified geometry is used for both to allow the example to concentrate on the use of the box section property calculator and the multiple varying section facilities that are used in modelling the structure.

3-Span Concrete Box Beam Bridge of Varying Section

Units used are kN, m, kg, s, C throughout

Objectives

The required output from the analysis consists of:

- ❑ A comparison of results from the preliminary model and the more detailed model.

Keywords

3D, Bridge, Beam, Span, Concrete, Multiple Varying Sections, Box

Associated Files

Associated files can be downloaded from the user area of the LUSAS website.



- ❑ **concrete_box_bridge.lvb** This script file creates an initial beam model for use with this example.

Discussion

The 3-span structure is comprised of varying hollow cross-sections with solid diaphragm sections at the four supports. Cross-section properties for three void locations on the structure (as shown in the image below) will be defined and used in the creation of multiple varying section geometric line attributes which will then be assigned to selected lines on the model.

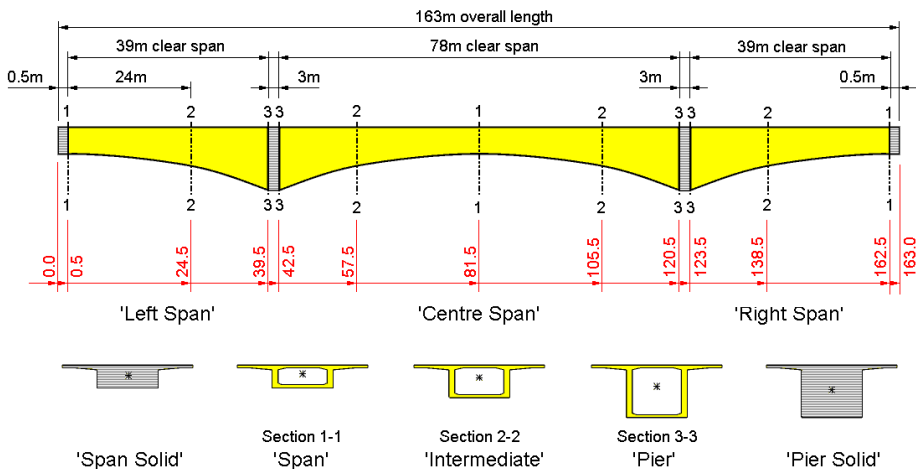

Schematic elevation showing the locations at which the varying section definitions are based.

Other section properties, for solid diaphragm sections at the supports and at the ends of the structure (shown on the image above), will also be defined and assigned as required.

Modelling approach

When modelling a structure of this sort, one of two approaches can be adopted.

- (1) The lines are drawn "flat" and an eccentricity is included in the box girder geometric attributes assigned to those lines accommodating the tapering sections as necessary
- (2) The lines are drawn coincident with the centroid of the box girder sections. No eccentricities are needed in the geometric attributes.

Using method (1) there is an approximation: vertical loads cross the nodal line at 90 degrees and so do not result in an axial force in haunching sections i.e. any "arching effects" are limited. However with the low rise and large spans of post-tensioned bridges, and the high compressive forces induced by the prestressing, this approximation is usually felt to be acceptable. Modelling by method (1) is much more straightforward in terms of creating geometry, especially for curved haunches, as in this example and furthermore the "flat lines" are more easily correlated to highway design lines and site measurements, hence it is adopted in this case.

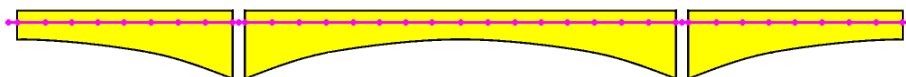

'Flat' modelling method
(where lines follow the centroid of one section with other sections offset to align to match)



Indicative diagram showing 'Curved' modelling method
(where all lines follow the centroid of sections)

Modelling details

The supplied basic beam model is a 'Flat' model with clear spans of 39m, 78m and 39m formed of single straight lines. During the initial part of the example multiple varying section geometric line attributes are assigned to the single lines along with other section properties and a simple linear analysis is carried out.

3-Span Concrete Box Beam Bridge of Varying Section

After creating the simple model a more detailed model is formed by splitting the lines representing each span into shorter 3m long lengths in readiness for a future staged construction analysis. In doing so 3 mesh divisions will be present on each 3m long geometric line.



Caution. When modelling cross sections that vary with constant section beam elements, care should be taken to ensure that sufficient elements have been assigned to the line(s) representing the tapering beam in order to achieve accuracy of results. If varying section beam elements are used, only one element per line may be required.

Modelling : Preliminary Model

Running LUSAS Modeller

For details of how to run LUSAS Modeller, see the heading *Running LUSAS Modeller* in the Examples Manual Introduction.

Creating a Model

- Enter a file name of **concrete_box_bridge_preliminary**
- Use the default **User-defined** working folder.
- Ensure an Analysis type of **3D** is set.
- Click the **OK** button.



Note. There is no need to enter any other new model details when the intention is to run a script to build an initial model, since the contents of the script will overwrite any other settings made.

-  To create the model, open the read-only file **concrete_box_bridge.lvb** that was downloaded and placed in a folder of your choosing.

The basic bridge geometry will be displayed.

The geometric lines of this model have been assigned a line mesh of thick beam elements with an element length of 1m. Concrete (ungraded) material properties and a structural gravity load have also been assigned. Fixed supports restrain the piers and roller supports restrain the ends of the deck.

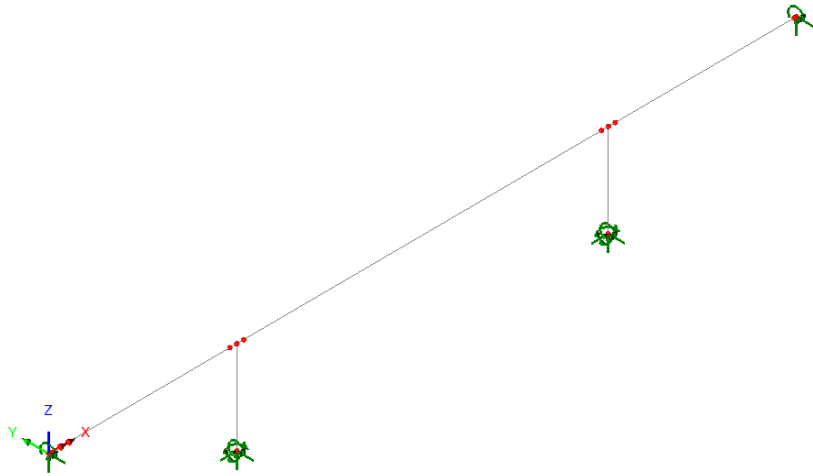

File
Save...

- Save the model.

Defining Cross-sectional properties

To start, cross-section properties for three voided box sections that are used in all three spans will be defined.

To define the voided span section

Attributes
Geometric >
Section library

- From the drop lists on the right of the dialog select **Parametric sections**, then **Box section**, then **New**.
- On the Box Section Property Calculator dialog select the **Complex section** option and enter values as shown on the dialog opposite.

Box section dimensions are:

- $H = 2.2$
- $W_b = 3$
- $W_t = 3$
- $H_m = 0$ (or leave blank)

Box Section Property Calculator

Type
 Simple section Exclude void
 Complex section

Cell details
 Number of cells: 1

Box section dimensions
 H: 2.2 Hm: 0
 Wb: 3 Tb: 0.2
 Wt: 3 Tt: 0.2
 w: Tw:

Cantilever slab dimensions
 Wc: 3.5 Tc1: 0.4
 Tc2: 0.2

Number of extra points
 Top slab: 1
 Bottom slab: 1
 Cantilever slab: 1
 Web interior face: 0
 Web exterior face: 0

Extra points locations

Point	Offset (O)	Height (H)
P1	2.5	0.4
P2	2.5	0.4
I1	1.65	0.2
b1	2	0.2
c1	1.27	0.2

Calculated properties

A	6.316
Ixx	4.26726
Iyy	61.6274
Ixy	0.0
J	8.76417
Asy	1.22098
Asx	3.79462
yt	0.81026
yb	1.38974

Name: Span (new)

OK Cancel Apply Help

3-Span Concrete Box Beam Bridge of Varying Section

- $T_b = 0.2$
- $T_t = 0.2$

Cantilever slab dimensions are:

- $W_c = 3.5$
- $T_{c1} = 0.4$
- $T_{c2} = 0.2$

To allow additional points to be entered in addition to P1 and P2, that are used to define the internal shape of the cross-section, the following need to be set in the Number of extra points panel:

- Top slab = 1
- Bottom slab = 1
- Cantilever slab = 1

Web interior face and web exterior face points are not required so are left set to zero.

The complete set of values to be entered in the Extra points locations table are:

Point	Offset (O)	Height (H)
P1	2.5	0.4
P2	2.5	0.4
t1	1.65	0.2
b1	2.0	0.2
c1	1.27	0.2

- Then, enter the name as **Span**
- To see the section and additional properties created and calculated by the values entered click the **Section details** button.

Section Details

Calculated properties

		Value
Cross sectional area	A	6.316
Second moment of area about x axis	I _{xx}	4.26726
Second moment of area about y axis	I _{yy}	61.6274
Product moment of area	I _{xy}	0.0
Torsional constant	J	8.76417
Effective shear area in x direction	A _{sx}	3.79462
Effective shear area in y direction	A _{sy}	1.22098
Radius of gyration about x axis	k _x	0.821965
Radius of gyration about y axis	k _y	3.12368
Warping torsional constant about shear centre	C _w	9.8766
Shear centre x distance from centroid	x _o	0.0
Shear centre y distance from centroid	y _o	-0.310953
Monosymmetry constant about x	betax	4.98336
Monosymmetry constant about y	betay	0.0
Wagner constant 1st moment of square radius about x	I _{xr}	18.6118
Wagner constant 1st moment of square radius about y	I _{yr}	-5.27874E-12
Wagner constant 4th moment of area about origin	I _{tr}	1.22755E3
Wagner constant 2nd moment of warping about origin	I _{wr}	-70.944E-6
Plastic section modulus about x axis	Z _{px}	4.32413
Plastic section modulus about y axis	Z _{py}	17.4797
Plastic torsional section modulus	Z _{pt}	9.58661
Plastic neutral axis, distance from centroid along x axis	x _p	0.0
Plastic neutral axis, distance from centroid along y axis	y _p	0.511241

Create annotation

Close Help

- Click **Close** to return to the main dialog.
- On the main dialog click **OK**.



Tip. Of the section properties calculated, one on the main dialog, y_t , (with a value of **0.81026** for this section) should be noted because it is used in subsequent calculations of eccentricity / offset values for other sections.



Note. If an incorrect value is noticed after defining the section, the Span entry in the Utilities  treeview should be edited as appropriate. After making any corrections press the **OK** to save the updated section data.

To define the voided intermediate section

The Span section will be edited and renamed to define the voided intermediate section.

- In the Utilities  treeview double-click on the **Span** entry.
- In the ‘Box section dimensions’ panel change the value of H to be **3.2**. The section properties will update automatically.

Box section dimensions

H	3.2	H _m	0.0
W _b	3.0	T _b	0.2
W _t	3.0	T _t	0.2
w	0.0	T _w	0.0

3-Span Concrete Box Beam Bridge of Varying Section

- Change the section name to be **Intermediate** and click **Apply** to add the section to the Utilities  treeview and allow you to continue to define another section.

To define the voided section adjacent to the pier

- In the 'Box section dimensions' panel change the value of H to be **5.2**
- Change the name to be **Pier** and click **Apply** to add the section to Utilities  treeview and allow you to continue to define another section.

To define the solid pier section

- In the 'Type' panel select **Exclude void**

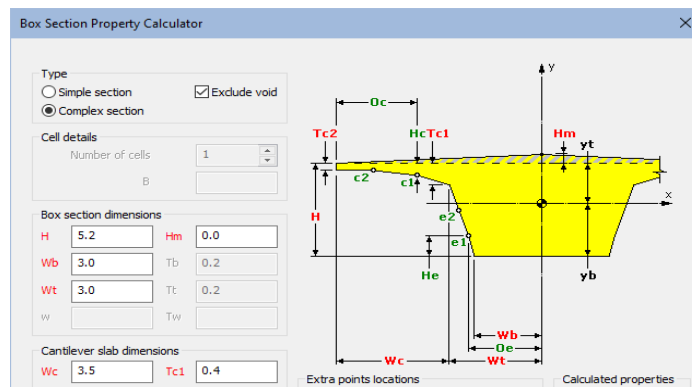

- Change the name to be **Pier Solid** and click **Apply** add the section to the local library and allow you to continue to define another section.



Tip. The difference between the yt value of the Pier Solid section and the Span section should be noted because this will be required later in the example to specify an eccentricity value for other sections. In this case the difference in values of yt is $2.4626 - 0.81026 = 1.65234$

To define the solid span section

Existing defined sections such as that of the voided span section can be loaded into the dialog for subsequent modification to create new or similar sections.

- Click the 'spinner' to the right of the 'Name' cell until 'Span' appears, then select **Span** to load its section details into the dialog.
- In the Type panel select **Exclude void**

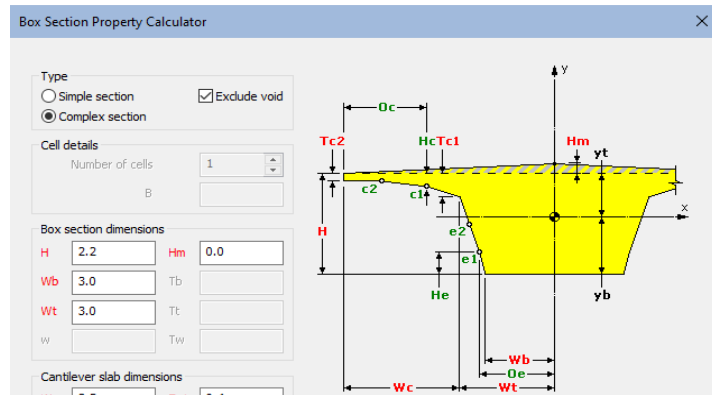

- Change the name to be **Span Solid** and click **OK** to add the section to the Utilities treeview, and finish defining the deck sections.



Tip. The difference between the 'yt' value of the Span Solid section and the Span section should be noted because this will be required later in the example to specify an eccentricity value of one from the other. In this case the difference in values of 'yt' is $0.98225 - 0.81026 = 0.17199$

The Utilities treeview should now contain:

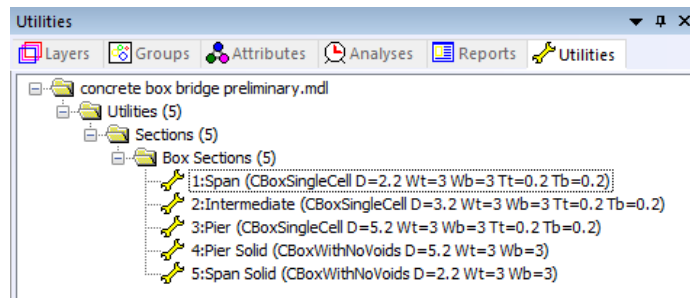

To define the column section

Attributes
 Geometric >
 Section library

- From the drop lists on the right of the dialog select **Parametric sections**, then **Rectangular sections**, then **New**.
- On the Rectangular Solid Section Property dialog enter D=6 and B=2.
- Change the name to be **Column** and click **OK** to finish defining section properties. An entry of Column (RSS D=6 B=2) will be added to the Utilities treeview,
- On the main Geometric line dialog press **OK** also. This will add a geometric attribute to the Attributes Treeview.

3-Span Concrete Box Beam Bridge of Varying Section



Note. When a 'New' section is defined from the **Attributes > Geometric > Section Library** menu item, or from the **Attributes > Geometric > Section Calculators** menu item, a section utility is created in the Utilities Treeview when the Apply button is pressed. If the OK button is subsequently pressed on the parent Geometric Line dialog a corresponding geometric line attribute that references this utility is also created in the Attributes Treeview. This attribute can be assigned directly to selected lines in a model.

All required section properties have now been defined and added to the Utilities treeview.

The voided span sections will be used to create multiple varying section line attributes which will be automatically added to the Treeview when the attribute is created.

Defining the multiple varying section line properties for the Left Span

A multiple varying geometric line attribute needs to be defined for the left-hand span. This will make use of the previously defined voided sections named Span, Intermediate and Pier.

Define sections

- On the Multiple Varying Section dialog, click in the Section cell that currently reads 914x305x289kg UB and the launch dialog button will appear to allow a different pre-defined section to be chosen from the section library.
- On the Enter Section dialog, select **Parametric sections**, then **Box sections**. Select **Span** and then click **OK** to add the section to the first row of the table on the Multiple Varying Section dialog.
- On the Multiple Varying Section dialog press the **TAB** key to move between cells and create a new row beneath the existing row. The Insert button may also be used. (Note that shape interpolation and distance values will be entered after all sections have been added to the table).
- In the new Section cell (row 2) click on the launch dialog button again. The drop-down list should still be showing **Parametric sections** and **Box sections**. Select **Intermediate** from the drop-down list and click **OK** to add the section to the table.
- Press the **TAB** key to move between cells and create a new row beneath the existing row.

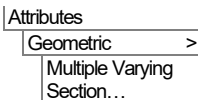

- In the new Section cell (row 3) click on the launch dialog button  again. The drop-down list should still be showing **Parametric sections** and **Box sections**. Select **Pier** from the drop-down list and click **OK** to add the section to the table.



Note. As the multiple varying section is built-up in the table, a visualisation of the longitudinal and vertical alignment and of the cross-section shapes used is displayed on the dialog. Longitudinal section visualisation only takes place once all required data has been entered and only for sections that are compatible.

Define shape interpolation method

To specify a shape interpolation method for each defined section:

- The **Span** section, as the first in the table, is set by default to **Start**
- For the **Intermediate** section entry ensure that the Shape Interpolation is set to be **Smoothed**
- Ensure that the Shape Interpolation for the **Pier** section is set to be **Smoothed**

Define distance values

Lastly, we need to specify a distance value at which each section will apply.

- For the **Span** section click in the Distance cell and enter **0.5**
- For the **Intermediate** section enter **24.5**
- For the **Pier** section enter **39.5** and click somewhere else on the dialog to cause the visualisation to be updated for the last entered distance.



Note. Values entered are treated as proportional distances along a line (for example entering values of 0, 10 and 20 would specify a section at either end and at a mid-point of any line that was selected and assigned the geometric line attribute). Distances are also mapped to the actual line length so entering 0, 0.5, and 1, in three separate cells would produce the same result. But note that a section does not necessarily have to be defined to start at a distance of 0 (as it doesn't in this example). In this case the use of a non-zero starting point of 0.5 (a chainage value representing the actual setting-out point of the section on the model) as well using a corresponding intermediate and an end point appropriate to the line beam length will help to ensure an easy conversion to a staged construction model in the second part of this example, which will use the same chainage values in conjunction with the reference path facility.

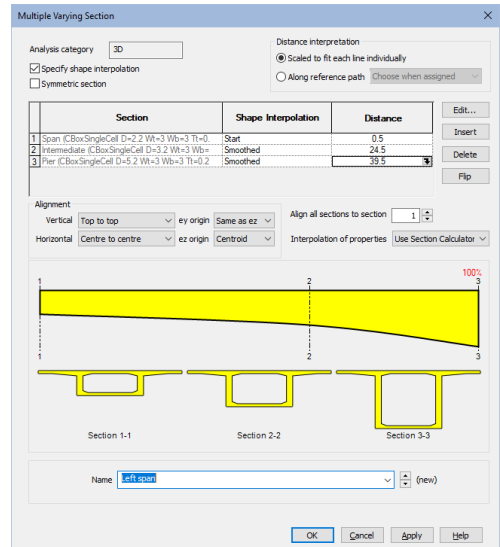

3-Span Concrete Box Beam Bridge of Varying Section

Check alignment settings

The vertical and horizontal alignment of a series of sections is controlled by the Alignment options. All sections are aligned with respect to a chosen section.

- Ensure the alignment settings are: **Top to top**, **Centre to centre** and with respect to section **1**

Name the attribute

- Enter a name of **Left Span** and click **Apply** to add the multiple varying section line attribute to the  Treeview and allow you to continue to define another one.

Defining the multiple varying section line properties for the Right Span

This can be done by reversing the order of the sections used for the left span and then changing the distance values. This time, to prevent inadvertent overwriting of previously defined line attributes, we will name the attribute first.

Name the attribute

- With the Multiple Varying Section dialog for the Left Span currently displayed overtype the Left Span name with **Right Span**

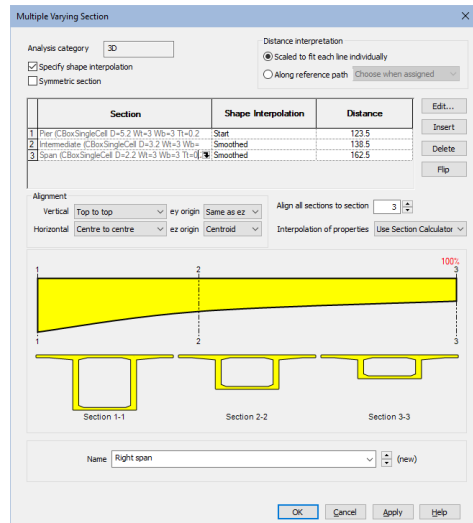

Define sections

- Click the **Flip** button to change the order of the sections listed.

Check shape interpolation type

- The **Pier** section should be set to **Start**
- The **Intermediate** section should be set to **Smoothed**
- The **Span** section should be set to **Smoothed**

Define distance values

- For the **Pier** section click in the Distance cell and enter **123.5**
- For the **Intermediate** section enter **138.5**
- For the **Span** section enter **162.5**

Check alignment

- Ensure that all sections are aligned **Top to top**, **Centre to centre** and with respect to section **3** (because this is now the number identifier for the Span section)

Apply the changes

- Click **Apply** to add the multiple varying section line attribute to the  Treeview and allow you to continue to define another one.

Defining the multiple varying section line properties for the Centre Span

This can be done by using the symmetric option to mirror the sections used for the Right Span and then changing the distance values.

Name the attribute

- With the Multiple Varying Section dialog displayed for the Right Span overwrite the Right Span name with **Centre Span**

Define sections

- Click the **Symmetric section** check box option to mirror the sections listed.

Check shape interpolation type

- The **Pier** section in row 1 should be set to **Start**
- The **Intermediate** section should be set to **Smoothed**
- The **Span** section should be set to **Smoothed**

Define distance values

Specify a distance value at which each section will apply:

- For the **Pier** section click in the Distance cell and enter **42.5**
- For the **Intermediate** section enter **57.5**
- Repeat for the **Span** section enter **81.5**

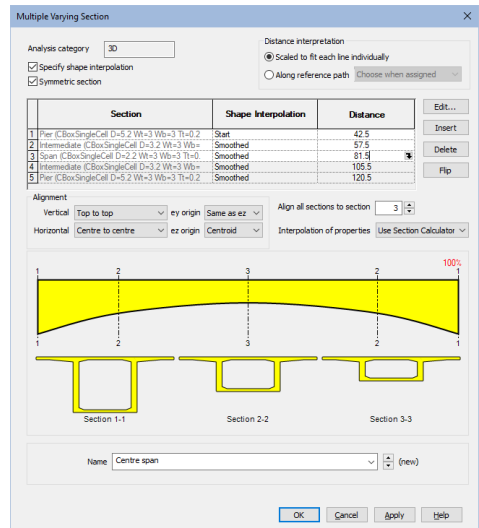

3-Span Concrete Box Beam Bridge of Varying Section

- Click somewhere else on the dialog to cause the visualisation to be updated for the last entered distance.

Check alignment

- Ensure that all sections are aligned with vertical alignment **Top to top**, horizontal alignment **Centre to centre**, and with respect to section **3** (the number identifier for the main setting-out section)

Save the changes

- Click **OK** to add the multiple varying section line attribute to the  Treeview and stop defining any more.



Note. Where all sections have been defined using either a LUSAS supplied standard library item, or one of the LUSAS standard section generators, an 'exact' calculation is made to arrive at intermediate section properties based upon the user-defined shape interpolation method.

Assigning the varying geometric line properties

- First, select the 39m long line representing the left-hand clear span of the bridge and drag and drop the **Left Span (Varying – 3 Sections)** geometric line attribute from the  Treeview onto it.



Note. There will be a short period of time whilst section property data is calculated for each element along the assigned line before the fleshed beam section is visualised.

- Next, select the 39m long line representing the right-hand clear span of the bridge and drag and drop the **Right Span (Varying – 3 Sections)** geometric line attribute onto it. This visualisation is quicker because section properties already exist.
- Lastly, Select the 78m long line representing the centre clear span of the bridge and drag and drop the **Centre Span (Varying – 5 Sections)** geometric line attribute onto it. After the section property data has been calculated for each element along the assigned line, the beam section will be visualised.

After assignment (and with fleshing turned on) the model will look like this:

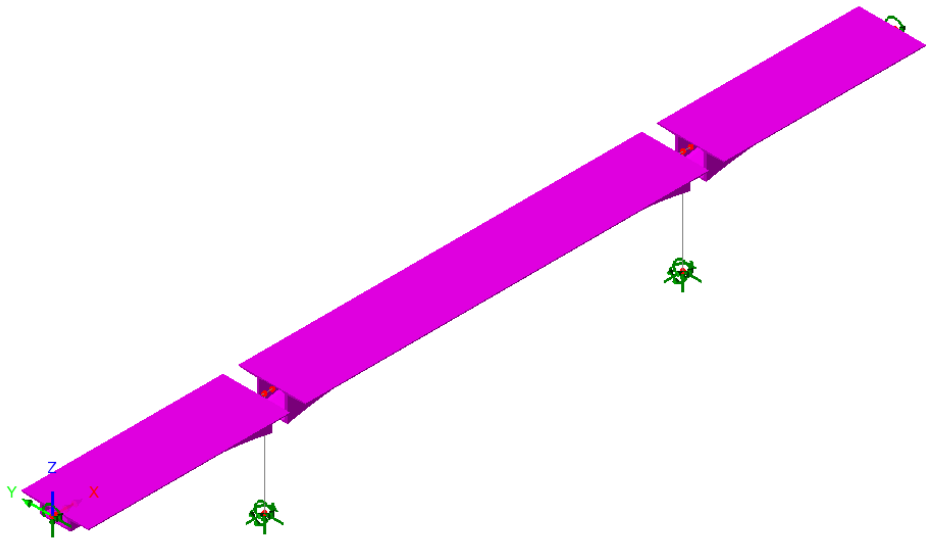

Assigning the solid geometric deck properties

The solid sections at the ends of the deck and at column locations now need to be assigned to the model.

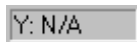

Select the **Y axis** button to view the side elevation of the model.



Note. The utility sections created earlier for these locations on the deck need to be converted into attributes to allow assignment to the model.

- In the Utilities  treeview right-click on **Span Solid** and select **Create attribute**. Enter the name as **Span Solid** and click **OK**.
- Repeat the above for **Pier Solid** to create an attribute named **Pier Solid**.
- Box-select the lines at either end of the bridge defining the solid section and drag and drop the **Span Solid (Span Solid)** geometric line attribute onto the selection. This assignment will be adjusted shortly.

3-Span Concrete Box Beam Bridge of Varying Section

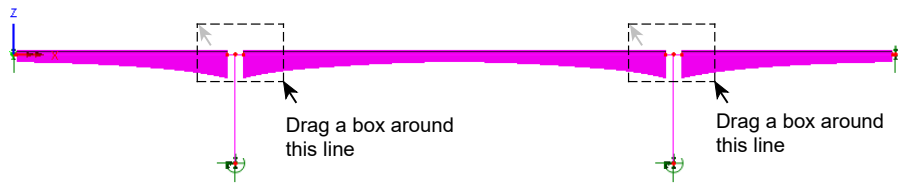

- Box-select the 2 lines at both internal supports defining the solid section of the deck and drag and drop the **Pier Solid (Pier Solid)** geometric line attribute onto the selection. This assignment will be adjusted shortly.

Adjusting the centroid offsets for solid sections

In assigning the geometric line attributes for the solid sections of the deck it can be seen that differences in centroid values in the y direction cause the solid sections to sit too high with respect to the varying sections (which were all set-out with a vertical alignment with respect to the centroid of the section named Span that sits at the left-hand end of the structure). As a result the offset values for these solid sections need amending.

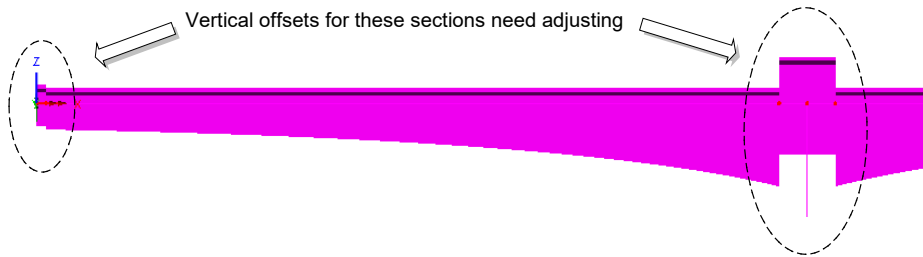

- In the  Treeview, double-click the **Span Solid (Span solid)** entry. Enter a value of **0.17199** for the Eccentricity in z direction (ez). This was calculated and noted with a Tip marker earlier in the example. Click **Apply** to make the change.
- On the Geometric Line dialog click the ‘spinner’ at the bottom of the dialog until the **Pier Solid** entry appears. For this entry, enter a value of **1.65234** for the Eccentricity in z direction (ez). This value was calculated and noted with a Tip marker earlier in the example. Click **OK** to make the change and close the dialog.

Assigning the main column properties

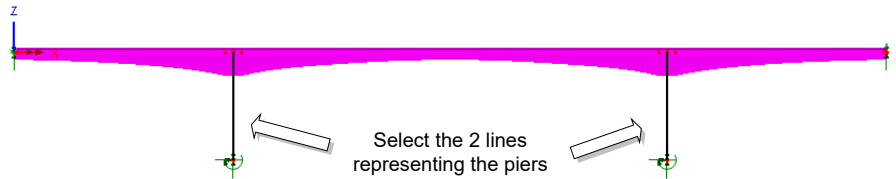

- Select the lines representing the columns (piers) and drag and drop the **Column (RSS D=6 B=2)** geometric line attribute onto the selection.
- Rotate the model to a suitable 3D view

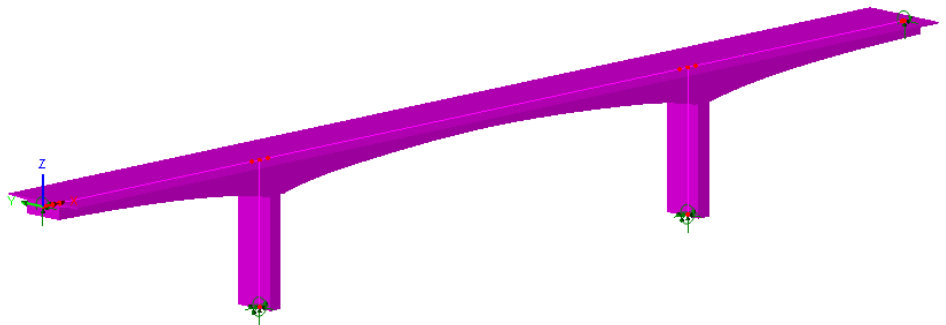

File
Save



Save the model file.

The preliminary model is now complete and ready to be solved.

Running the Analysis : Preliminary Model



On the **Solve Now** dialog ensure **Analysis 1** is checked and press **OK** to run the analysis.



Note. Normally a general warning relating to the use of sufficient constant beam elements will be displayed whenever a model containing multiple varying geometric line attributes is solved. However, for this example, it has been turned off.

If the analysis is successful...

Analysis loadcase results are added to the  Treeview.

In addition, these files will be created in the LUSASFiles32\`<model_name>` folder:



- ❑ **concrete_box_bridge_preliminary.out** this output file contains details of model data, assigned attributes and selected analysis statistics.
- ❑ **concrete_box_bridge_preliminary.mys** this is the LUSAS results file which is loaded automatically into the  Treeview to allow results to be viewed.

If the analysis fails...

If the analysis fails, information relating to the nature of the error encountered is written to the output files in addition to the text output window. Any errors listed in the text output window should be corrected in LUSAS Modeller before saving the model and re-running the analysis.

Viewing the Results : Preliminary Model

Analysis loadcase results are present in the  Treeview.

Add a contour layer

- With no features selected click the right-hand mouse button in a blank part of the Graphics window and select the **Contours** option to add the contour layer to the  Treeview.
- From the drop down menu in the dialog, pick **Stress** from the entity drop down list and pick **Sx(Fx, My, Mz)** from the component drop down list.
- Click **OK** to display stress contours on the fleshed shape.

Add a diagrams layer

- With no features selected click the right-hand mouse button in a blank part of the Graphics window and select the **Diagrams** option to add the diagrams layer to the  Treeview.
- From the drop down menu in the dialog, pick **Force/Moment** from the entity drop down list and **My** from the component drop down list.
- Select the **Diagram Display** tab and ensure that **Label values** and **Peaks only** are both selected. Select the **Scale** tab and enter a magnitude of **18**. Click **OK** to display

a bending moment diagram on the fleshed shape that is marked only with peak values for clarity.

Analysis: Analysis 1
 Loadcase: 1:Loadcase 1
 Results file: concrete_box_bridge_preliminary~Analysis 1.mys
 Entity: Stress - Thick 3D Beam
 Component: Sx(Fx, My, Mz) (Units: kN/m²)

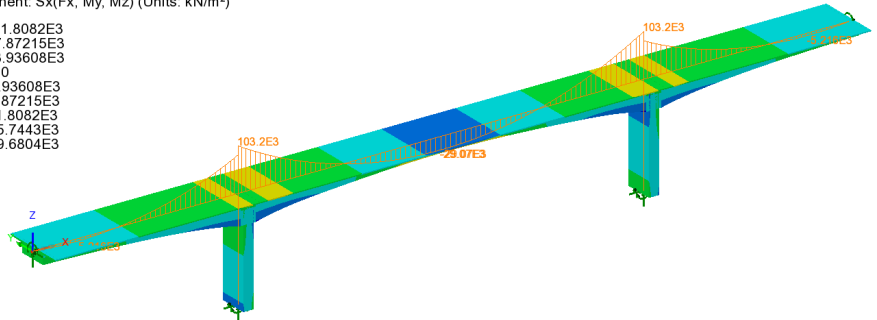
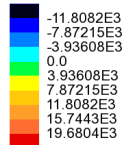

Notes. When plotting results of beam stress for results components that contain a moment term such as Sx (Fx, My, Mz) or Sx(My) the results contours displayed on a fleshed model are accurately represented by the colours shown in the contour key. However, because the contours are being drawn for all locations on the section (an infinite number of y/z locations) at the same time, the maximum and minimum values cannot be stated on the contour key because they are based upon estimated values.

Beam stress contours plotted on an unfleshed model are precise and are drawn for a specified active fibre location.

This completes the preliminary part of the example.

Modelling : Detailed Model

The preliminary model has clear spans of 39m, 78m and 39m formed of single lines. A more detailed model is to be formed by splitting the lines representing each span into shorter 3m long lengths in readiness for a future staged construction analysis. To allow this to happen a reference path is created and the multiple varying section geometric line attributes are updated to make use of the reference path that is defined prior to the lines representing the spans being split into the smaller number of line divisions. No re-assignment of geometric properties need be made to the lines created by splitting the existing lines. The multiple varying section geometric line attributes will automatically be applied to the lines using the reference path facility.

File _____
 Save As... _____

- Confirm that all results files will be closed, and then enter the model file name as **concrete_box_bridge_detailed** and click the **Save** button.

Changing the model description

File
Model Properties...

- Change the model title to **Concrete Box Beam Bridge Detailed Model** and click **OK**

Creating a reference path

A reference path defines a route through a model that provides a concept of distance to each point in the model. Those distances can be used in the definition of a varying section, such that when the section is assigned to lines, the path is used to interpret which part of the section is appropriate to each line. Bridge engineers refer to this reference path concept as chainage.

For this example and for clarity a reference path will be defined above the model using the path definition dialog.

Utilities
Reference Path

- Enter coordinates of **(0, 0, 10)** in the first row of the table. Press the **TAB** key and enter coordinates of **(163, 0, 10)** in the second row, ensuring the **Type** remains **Straight**, as default.
- Click elsewhere in the grid to update the graphic and then click **OK** to define a reference path above and of the same overall length as lines defining the deck in the model. A corresponding path definition entry will be created in the  Treeview.

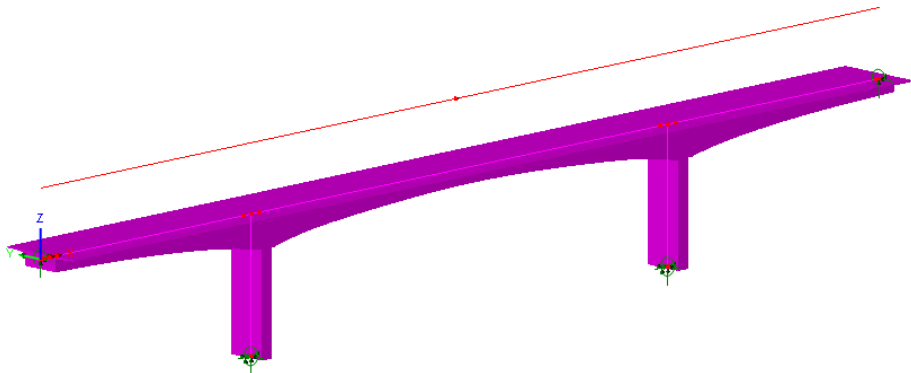



Note. In its simplest form a reference path can be defined as a line between two points (and quite separate from the model data, as in this case) if a straight path is to be considered, or be created from the model geometry itself and contain as many defining points as the lines from which it has been created (by using the Utilities > Reference Path menu item) in which case the coordinates of all lines selected would be listed in

the Path Definition table. If the latter is done it is important to remember that whilst the model geometry has been used to arrive at the points required to generate a reference path, no connection between the model geometry and reference path data exists.

Editing multiple varying section geometric properties

To make use of the reference path all multiple varying section geometric line attributes need to be edited to refer to it.

- In the  Treeview, double-click the **Left Span (Varying - 3 Sections)** entry.
- On the Multiple Varying Section dialog change the Distance Interpretation setting to **Along reference path** and ensure that **Path1** is selected. Click **OK** to update.
- Repeat the above procedure to specify a reference path for the **Right Span (Varying - 3 Sections)** entry in the  Treeview.
- Repeat the above procedure to specify a reference path for the **Centre Span (Varying - 5 Sections)** entry in the  Treeview.

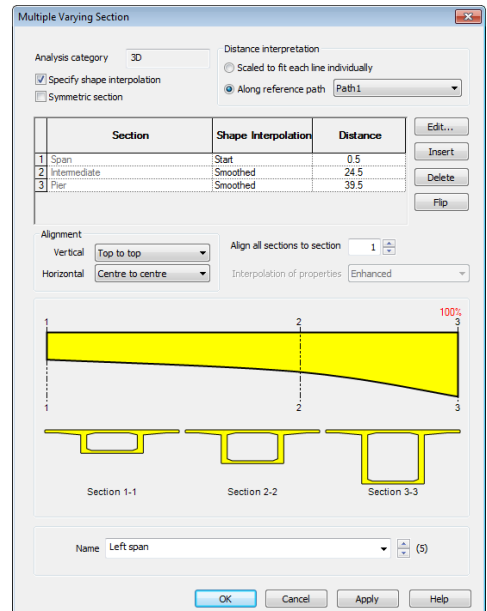

Split the lines representing the clear spans

The single lines representing each clear span are to be split into 3m lengths to represent each proposed construction stage.

- Select the two 39m long lines representing the left and right clear spans of the bridge.

3-Span Concrete Box Beam Bridge of Varying Section

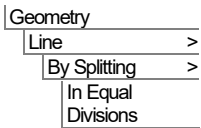
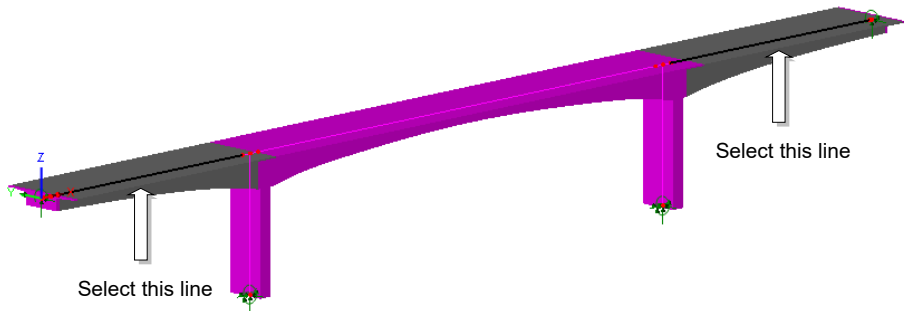

- Select **Use same divisions for all lines** and enter **13** for the number of divisions. Ensure that **Delete original geometry after splitting** is selected and press **OK**.
- Lastly, select the 78m long line representing the centre span of the bridge.

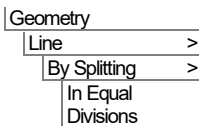
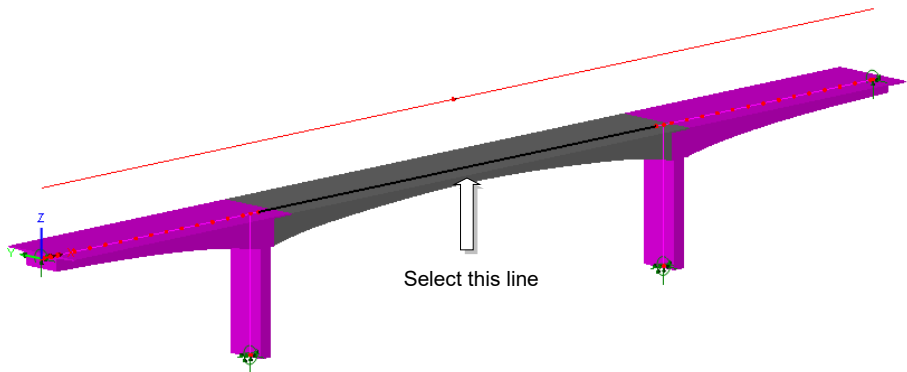

- Enter **26** for the number of divisions and ensure that **Delete original lines after splitting** is selected.

Splitting the lines in this way produces the following model which is now ready for further manipulation (not covered in this example) to allow a staged construction analysis to be carried out. Pressing the fleshing on/off button will show the basic line geometry in isolation from the fleshing.

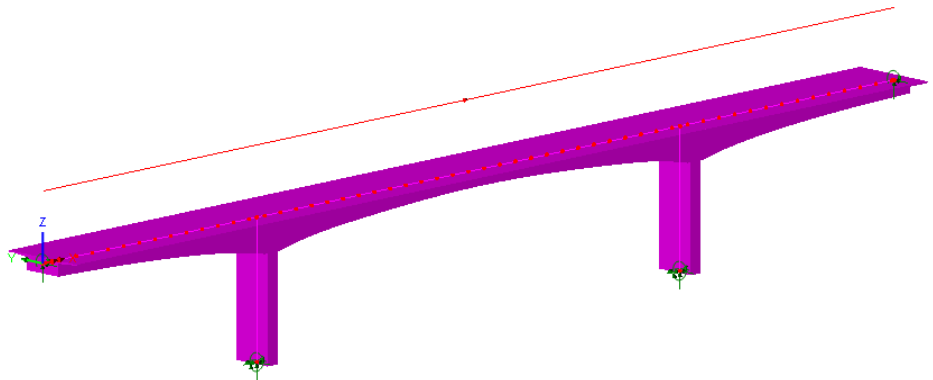

File
Save



Save the model file.

The detailed model is now complete and ready to be solved.

Running the Analysis : Detailed Model



Open the **Solve Now** dialog. Ensure **Analysis 1** is checked and press **OK** to run the analysis.

If the analysis is successful...

Analysis loadcase results are added to the  Treeview.

In addition, 2 files will be created in the Associated Model Data directory where the model file resides:



- concrete_box_bridge_detailed.out** this output file contains details of model data, assigned attributes and selected analysis statistics.
- concrete_box_bridge_detailed.mys** this is the LUSAS results file which is loaded automatically into the  Treeview to allow results to be viewed.

If the analysis fails...

If the analysis fails, information relating to the nature of the error encountered is written to output files in addition to the text output window. Any errors listed in the text output window should be corrected in LUSAS Modeller before saving the model and re-running the analysis.

Viewing the Results : Detailed Model

When the detailed model has been built immediately after creating and viewing results for the preliminary model, the Contour and Diagrams layers will already be present in the  Treeview and the stress contours and diagram plot will be as shown below.

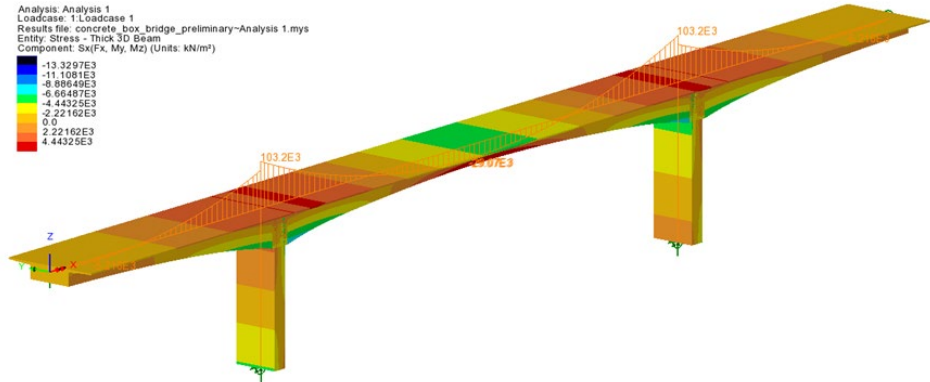

This completes the detailed modelling part of the example.