

# Defining p-y Curves for a Piled Integral Bridge

For LUSAS version:	21.1
For software product(s):	LUSAS <i>Civil &amp; Structural</i> or LUSAS <i>Bridge</i> .
With product option(s):	Nonlinear.

## Description

A model is supplied of a single span integral bridge with abutments supported on two rows of piles. P-y curves are defined, and associated joints introduced into the model to represent the support from the soil to the piles that resist the applied loading to the structure. Diagrams of bending moments in the piles are obtained from self-weight, active soil pressure, and live load (UDL) loadcases.

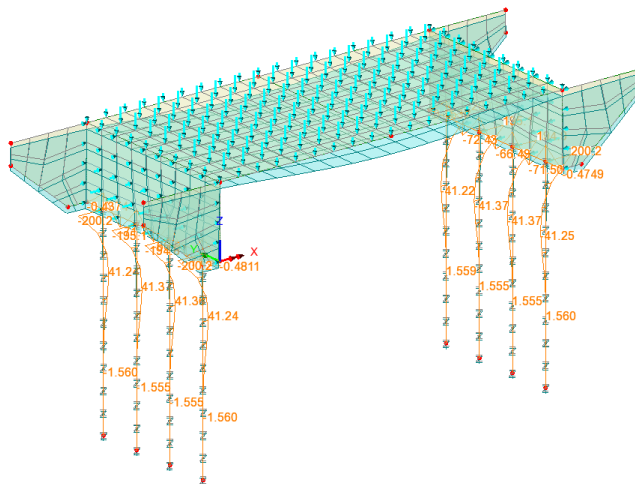

## Defining p-y Curves for a Piled Integral Bridge

---

Units used are kN, m, t, s, C throughout.

### Objective

- To model the soil supporting the piles with an appropriate p-y curve and obtain diagrams of bending moment in the piles.

### Keywords

3D, Integral Bridge, Deck, Wing Walls, Piles, p-y Curves, Joints

### Associated Files

Associated files can be downloaded from the user area of the LUSAS website.



- integral\_bridge\_py\_curves\_preliminary.lvb** creates the basic model geometry. The example uses the model created by the file as a starting point.

## Modelling

### Running LUSAS Modeller

For details of how to run LUSAS Modeller, see the heading *Running LUSAS Modeller* in the *Introduction to LUSAS Worked Examples* document.

**Note.** This example is written assuming a new LUSAS Modeller session has been started. If continuing from an existing Modeller session select the menu command **File>New** to start a new model file. Modeller will prompt for any unsaved data and display the New Model dialog.

### Creating a New Model

- Enter a file name of **integral\_bridge\_py\_curves**
- Use the default **User-defined** working folder.
- Ensure an Analysis type of **3D** is set.
- Click the **OK** button.



**Note.** There is no need to enter any other new model details when the intention is to run a script to build an initial model, since the contents of the script will overwrite any other settings made.



To create the model required for this example, open the script file **integral\_bridge\_py\_curves\_preliminary.lvb** that was downloaded and placed in a folder of your choosing.

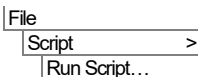
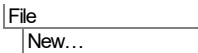

The bridge is modelled with thick shell elements for the bridge deck, abutments and wingwalls, and thick beam elements for the pile caps and piles.

To view the model as intended within this example:

- From the  treeview drag and drop the Saved view **model view** onto the view window.



Press the **Fleshing on/off** button to view the fleshed members of the bridge.

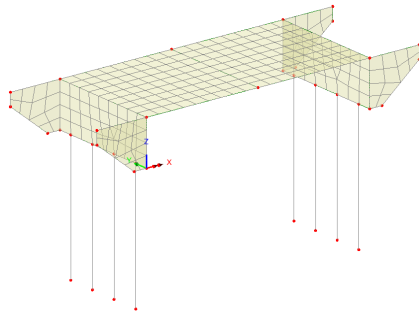

Unfleshed model

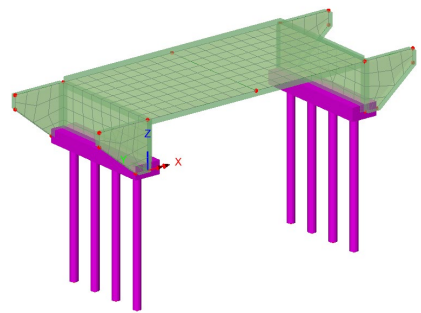

Fleshed model



- **Retain the unfleshed model** view for the remainder of this example.

### Define a line mesh

- On the Line mesh dialog select an element type of **Joint no rotational stiffness**.
- Enter a name of **Joint for piles** and click **OK**.

### Assign a line mesh

A group has been defined to aid easy selection of the piles.

- In the  treeview right click on **Piles** and choose **Select Members**.
- From the  treeview drag and drop the **Joint for piles** line mesh attribute onto the selected features.

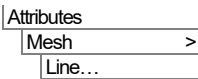

## Defining p-y Curves for a Piled Integral Bridge

- On the Joint line assignment dialog select **Support line via joints** and click **OK**.

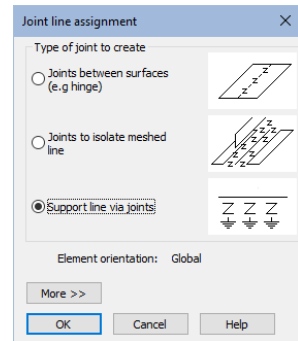

If not already visible, press the **Support On/Off** button to visualise the supports.

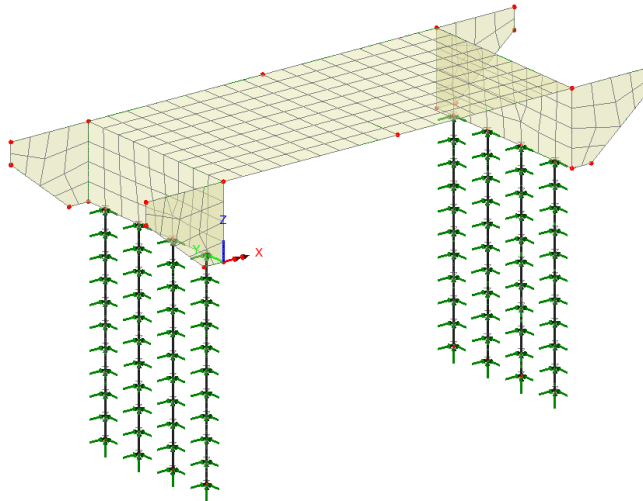

Press the button again to turn off the visualisation of the supports

### Defining embedded pile material

The soil that the piles are embedded in comprises three layers starting with a backfill material, which extends from behind the top of the abutments down to include the top 1m of the piles. This is followed by a sandy silt layer, 3m in thickness, and finally the pile is embedded in clay. The water level is stated to be 3m below the top of the pile.



**Note.** Layers are defined top-down with reference to the model's vertical axis, hence each layer defined should have a smaller (or more negative) Z-value than its predecessor.

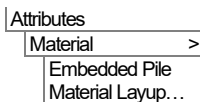

On the embedded pile material layout dialog:

- Enter a value of **3.5** for the top of first layer, select the **Backfill** item from the drop-list, and press the **TAB** key to create a new row beneath this first row.
- Enter a value of **-1** (minus 1) for the top of second layer, select the **Sandy silt** item from the drop-list and press the **TAB** key.
- Enter a value of **-4** (minus 4) for the top of second layer, select the **Clay** item from the drop-list.
- Specify the Water level to be at **-3** (minus 3)
- Specify the base of piles to be **Plugged**.
- Deselect the **Full displacement piles** check box and leave other settings and values as their defaults. The dialog should look like this:

	Top of layer (Z)	P-y curve
1	3.5	1:Backfill
2	-1.0	2:Sandy silt
3	-4.0	3:Clay

Analysis category: 3D

Water level (Z): -3.0

Base of piles: Plugged

Surcharge at top of layer 1: 0.0

Full displacement piles:

Name: Site soil layers (2)

- Enter a material name of **Site soil layers** and click **OK**.



**Note.** For this example, for ease of use, the p-y curves for the backfill, sandy silt and clay layers have been pre-defined. They can otherwise be defined either from the Utilities > P-y curve menu item, or by choosing 'New' from p-y curve droplist of the Embedded Pile Material Layout dialog. The Edit button allows customisation of the properties of individual layers for project use.



**Note.** The 'Full displacement piles' option would only be selected if driven rather than bored piles have been specified. In this example a circular solid section (CSS) is

## Defining p-y Curves for a Piled Integral Bridge

---

being used, which is typical for a bored/CFA pile, as opposed to a driven precast pile, which is usually a square solid section.

### Assign the embedded pile material

With all piles still selected:

- From the  treeview drag and drop the material **Site soil layers** onto the selected features.
- On the resulting dialog, select the **Specified** option to define ground level to be at the top of the abutment, which is a value of **3.5** (m) above the model view axis, then click **OK**.

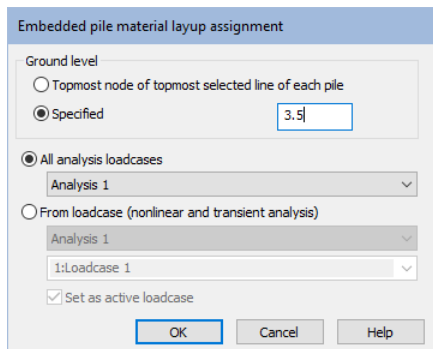

**Note.** Setting the soil level to be at the top of the abutment will result in stiffer p-y curves than would be obtained with the top of soil being at the top of pile level. For a bridge on an embankment, the initial stiffness of the soil isn't affected much by the overburden of the embankment until there has been time for consolidation etc. So, arguably, specifying ground level to be top of pile would be reasonable for the early life of the bridge, and probably conservative.

### Set nonlinear controls

As p-y curves are nonlinear, nonlinear controls need to be added.

- In the  treeview right click on **Loadcase 1** and from the **Controls** menu item select **Nonlinear & Transient**.
- On the dialog, in the Incrementation section, select the **Nonlinear** check box and ensure **Manual** incrementation is chosen, leave all other settings as their defaults and click **OK**.

**Nonlinear & Transient**

**Nonlinear**

Incrementation:  (dropdown)

Starting load factor:

Max change in load factor:

Max total load factor:

Adjust load based on convergence

Iterations per increment:

Time domain

(dropdown)

Initial time step:

Total response time:

Automatic time stepping

Save a restart at the end of this control

**Solution strategy**

Same as previous loadcase

Max number of iterations:

Residual force norm:

Displacement norm:

**Incremental LUSAS file output**

Same as previous loadcase

Output file:

Plot file:

Restart file:

Max number of saved restarts:

Log file:

History file:

**Common to all**

Max time steps or increments:

### Loading

Gravity has been turned 'on' as a default in Loadcase 1. This loading will be used to confirm the model is defined correctly and will solve before adding further loadcases.

### Save the model

File  
Save



Save the model file.

## Running the analysis for an initial model check

With the model loaded:



Select the **Solve Now** button from the toolbar and click **OK** to run the analysis.

A LUSAS Datafile will be created from the model information. The LUSAS Solver uses this datafile to perform the analysis.

### If the analysis is successful...

Analysis loadcase results are added to the  Treeview

In addition, these files will be created in the LUSASFiles32\`<model_name>` folder:



- integral\_bridge\_py\_curves.out** this output file contains details of model data, assigned attributes and selected statistics of the analysis.
- integral\_bridge\_py\_curves.mys** this is the LUSAS results file which is loaded automatically into the  Treeview to allow results processing to take place.

### Viewing the results for the gravity only loadcase

Analysis loadcase results are present in the  Treeview and loadcase **Loadcase 1** will be automatically set active. A deformed mesh layer will be added and automatically displayed.

- With no features selected, click the right-hand mouse button in a blank part of the view window and select the **Diagrams** option to add the diagrams layer to the  Treeview.
- Select entity **Force/Moment** and component **My** and click **OK**.

By default, values will be displayed for each node.

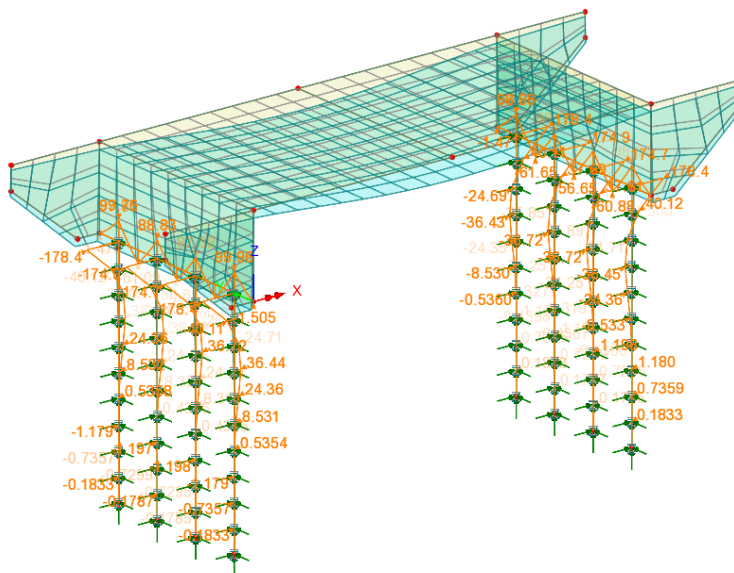



- Revisit the Diagrams properties dialog and select the **Diagrams Display** tab, then select **Peaks only** to simplify the display.

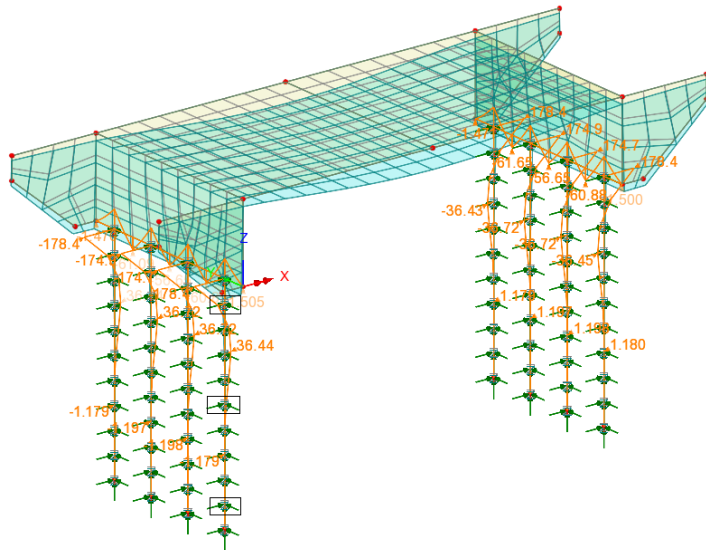

### View soil support stiffnesses with respect to depth

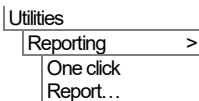

- With reference to the previous image and using the **Select Elements** cursor, for one of the piles use the **Shift** key to make three box selections to select a joint element (JNT4) towards the top of the pile, one in the middle and one towards the bottom.

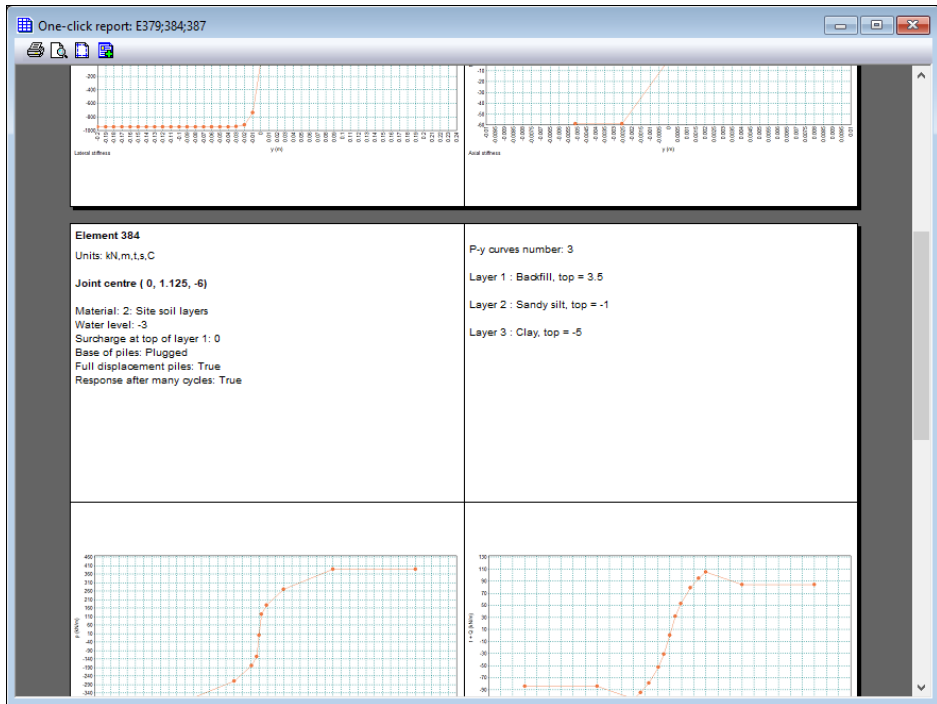

A three page report will be generated and show the changing soil support stiffnesses with respect to depth.

## Defining p-y Curves for a Piled Integral Bridge



- Close the one-click report window.
- In the  treeview, turn off the display of the **Diagrams** layer.
- In the  treeview, turn off the display of the **Deformed mesh** layer.

## Defining additional loadcases

Now the model has been initially solved, and the basic behaviour has been seen to be as expected, two additional loadcases will now be added.

- Loadcase 2:** Soil pressure to the abutment walls (manual)
- Loadcase 3:** Live load (UDL) to the deck (manual)



**Note.** Because p-y curves are nonlinear, the use of basic or smart load combinations using linear superposition cannot be employed. Instead, additional loadcases will be created by copying a previous loadcase and manually adding the additional loading required to create a “total load” for each loadcase. This effectively creates a separate analysis for each scenario.





**Note.** When specifying manual nonlinear control, loading must be assigned to each loadcase as a “total load” with gravity and any specific loading for a loadcase assigned

to each. It is only possible to assign gravity to the analysis itself at the “analysis level” if automatic nonlinear control is being used, which it isn’t in this example.

### Create loadcase 2

Loadcase 2 will include the previous gravity loading and additionally the soil pressure loading to the abutments.

- In the  Treeview right-click on **Loadcase 1** and select **Copy** and then repeat and select **Paste**.
- In the  Treeview right-click on **Loadcase 1 (Copy)** and rename it to be **Loadcase 2**





**Note.** Because results were previously obtained and the model is now being edited, the View window will carry the wording “Modification Mode” and “Results are out of date” until the model is solved again.

### Defining soil pressure to abutment walls

- Select a **General Field Variation** and click **Next**.
- Enter a Function of **-1.8\*9.81\*(Z-3.5)**
- Enter a name of **Vertical soil pressure** and click **Finish**.
- Select **Distributed loads**, then **Global distributed** and click **Next**.
- Select **Per unit area** and for the X direction enter **0.3\*Vertical soil pressure**
- Enter a loading name of **Active soil pressure** and click **Finish**.

### Assign soil loading to left-hand abutment

This has to be done in isolation from the right-hand abutment because the surface axes of the surfaces representing the abutments are the same orientation. (If required, these could be checked by accessing the Geometry layer entry in the Layers  treeview and turning on the Surface axes option)

- Select the surface representing the left-hand abutment and from the  treeview drag and drop the material **Active soil pressure** onto the selected feature.
- On the loading assignment dialog ensure that **Single loadcase** and **Loadcase 2** is selected and click **OK**. By default this will assign the loading with a default load factor of **1.0**.

Utilities

Variation...

Attributes

Loading...

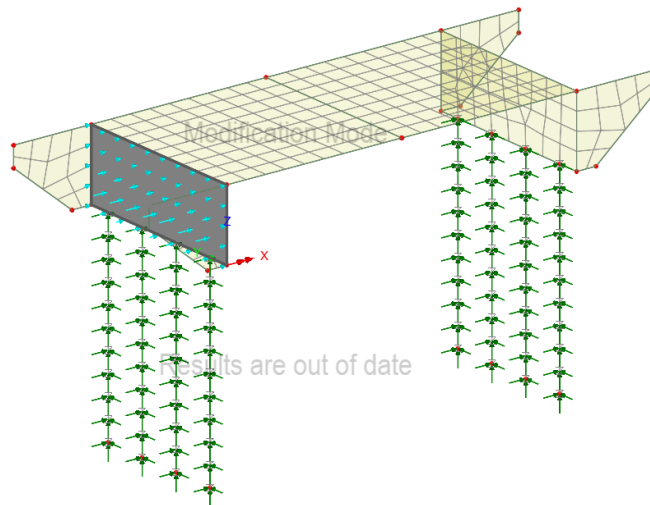

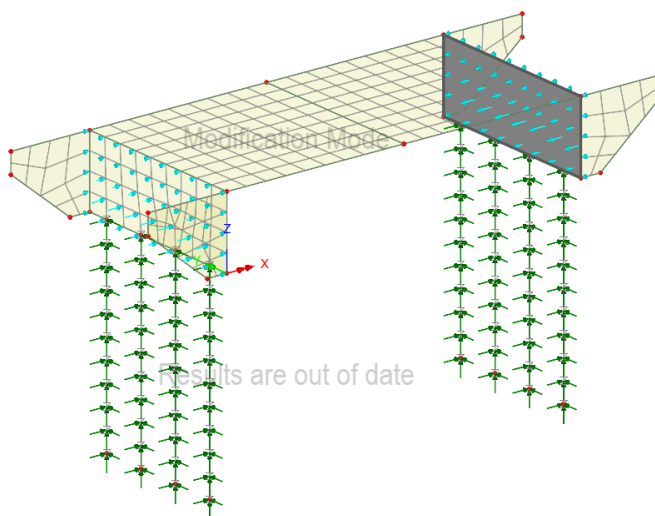

### Assigning soil loading to right-hand abutment

- Now select only the surface representing the right-hand abutment and from the  treeview drag and drop the material **Active soil pressure** onto the selected feature.
- Ensure the loading is assigned to a **Single loadcase** named **Loadcase 2** and click the **More...** button.
- Change the load factor to be **-1.0** and click **OK**. This will assign the loading in the appropriate direction for the selected surface.



## Create loadcase 3

Loadcase 3 will include all previous loadings and additionally the live load (UDL) to the deck.

- In the  Treeview right-click on **Loadcase 2** and select **Copy** and then repeat and select **Paste**.
- In the  Treeview right-click on **Loadcase 2 (Copy)** and rename it to be **Loadcase 3**

## Defining live loading (UDL) to deck slab

- Select **Distributed loads**, then **Global distributed** and click **Next**.
- Select **Per unit area** and for the **Z** direction enter **-5**.
- Enter the load name as **Live load (UDL)** and click **Finish**.

## Assigning live loading to deck slab

- Select both surfaces representing the deck and from the  treeview drag and drop the material **Live load UDL** onto the selected features.
- Ensure the loading is assigned to a **Single loadcase** named **Loadcase 3** and click **OK**.

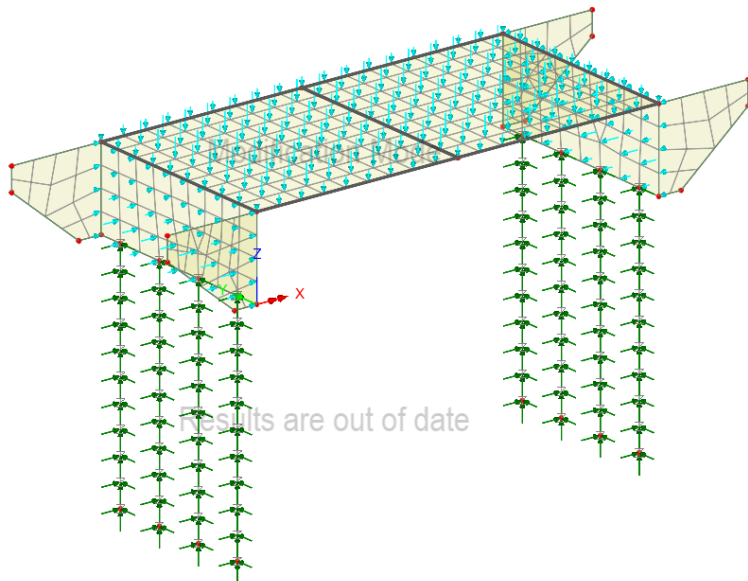

Attributes  
Loading...

## Defining p-y Curves for a Piled Integral Bridge

The resulting  Treeview will look like this:

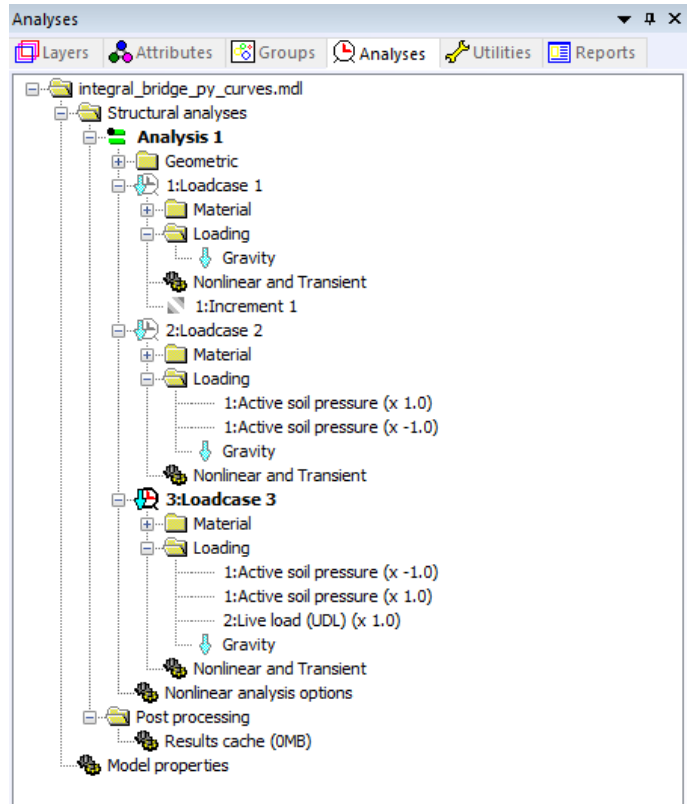

**Note.** Copying and pasting of loadcases with nonlinear and transient controls will also copy the controls of the chosen loadcase. Loadcase 1 is set to use nonlinear manual control and as a result all subsequent loadcases will also be assumed to have nonlinear manual control unless alternative control is defined. Whilst nonlinear and transient controls are seen to be present for Loadcase 2 and Loadcase 3 they are effectively redundant in this example and could be deleted.



## Running the analysis



Select the **Solve Now** button from the toolbar and click **OK** to run the analysis.

## Viewing the results

- In the  Treeview ensure **Loadcase 3** is set active.

- In the  treeview turn on the display of the **Diagrams** layer.
- In the  treeview turn on the display of the **Deformed mesh** layer.

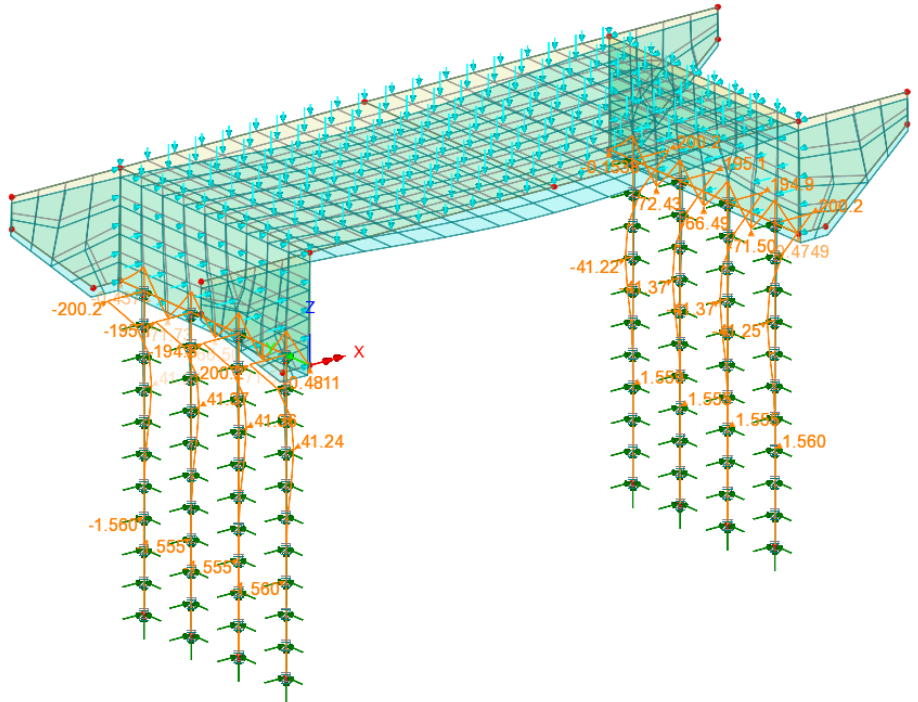

- By setting each loadcase active in turn, the change in bending moment in the piles from the effect of each can be viewed.

This completes the example.