

Simple Slab Deck

| | |
|--------------------------|-----------------------|
| For LUSAS version: | 21.1 |
| For software product(s): | LUSAS <i>Bridge</i> . |
| With product option(s): | None. |

Description

A simply supported bridge structure consisting of an in-situ slab deck is to be analysed. The geometry of the deck is as shown. The slab has 0.5m thick carriageways and 0.4m thick footways.

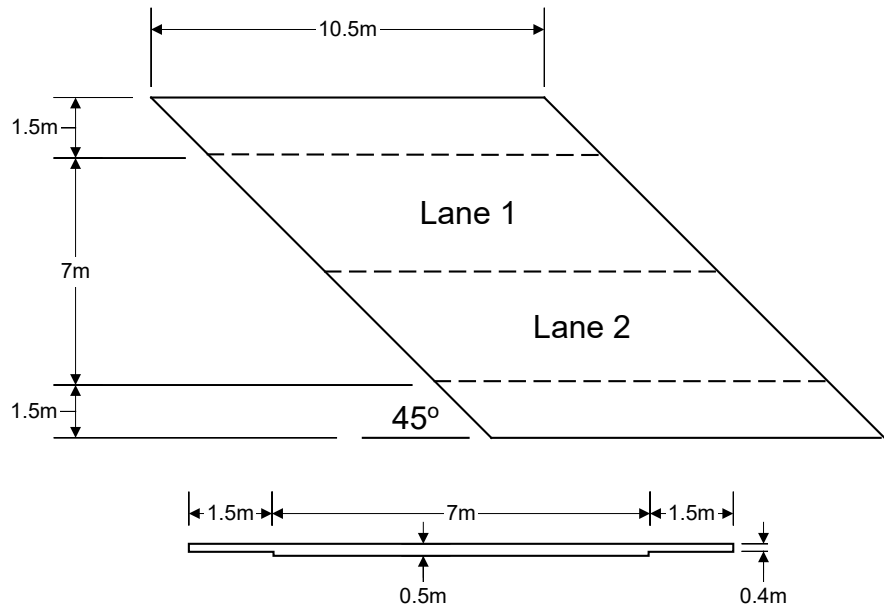

The structure is subjected to loading defined in the Departmental Standard BD 37/88 Loads for Highway Bridges.

The units of the analysis are kN, m, t, s, C throughout.

Objectives

The required output from the analysis consists of:

- A deformed shape plot showing displacements caused by the imposed loading
- A diagram showing the bending moments in the slab

Keywords

3D Beam/Shell, Bridge Loading, Moving Load, Eccentricity, Basic Load Combination, Load Envelope, Peak Values, Deformed Mesh, Contours, Graphing.

Associated Files

Associated files can be downloaded from the user area of the LUSAS website.



- bridge_slab_modelling.lvb** carries out most of the modelling of the example. After running the script go to the heading entitled **Assigning the Moving HB Vehicle Load** and continue from this point.

Modelling



Note. Model and results images included in this example were captured in an earlier version and may differ in appearance from those seen and obtained from this version.

Running LUSAS Modeller

For details of how to run LUSAS Modeller, see the heading *Running LUSAS Modeller* in the *Introduction to LUSAS Worked Examples* document.



Note. This example is written assuming a new LUSAS Modeller session has been started. If continuing from an existing Modeller session select the menu command **File > New** to start a new model file. Modeller will prompt for any unsaved data and display the New Model dialog.

Creating a new model

- Enter the file name as **bridge_slab**
- Use the **Default** working folder.
- Ensure an Analysis type of **Structural** is set.
- Set the Analysis category as **3D**
- Change the model units to **kN,m,t,s,C**
- Ensure that timescale units are **Seconds**

- Select the Startup template **3D Beam/Shell**
- Ensure the Layout grid is set as **None**
- Enter the title as **Simple Bridge Slab Analysis**
- Click **OK**

The Attributes  treeview will be populated with potentially useful basic line mesh, material, geometric and support entries appropriate to the settings made.



Note. An analysis category of 3D and a 3D Beam/Shell template is specified because eccentricities will be defined that provide in-plane effects, which cannot be obtained from a 2D model.



Note. Use the undo button to correct a mistake. The undo button allows any number of actions since the last save to be undone.

Defining the Material

Ungraded concrete material is provided by the startup template.

- Select the **Concrete (Ungraded | Concrete)** attribute from the  Treeview with the right-hand mouse button and select **Set Default** to make concrete the default material for all newly created features.

Feature Geometry

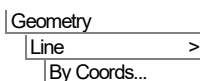

Enter coordinates of **(0, 0)**, **(10.5, 0)** to define the lower Line. Use the **Tab** key to move to the next entry field on the dialog. With all the coordinates entered click the **OK** button.

- Select the line.

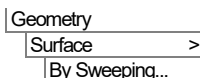

Sweep the line through a translation of $X = -1.5$, $Y = 1.5$, $Z = 0$ and click **OK** to create a Surface which defines the lower footway.

- Select the Line at the top of the footway.

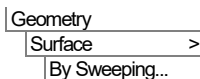

Sweep the Line through a translation of $X = -7$, $Y = 7$, $Z = 0$ and click **OK** to create a Surface which defines the carriageway.

- Select the Line at the top of the carriageway.

Simple Slab Deck

Geometry
Surface >
By Sweeping...



Sweep the Line through a translation of $X = -1.5$, $Y = 1.5$, $Z = 0$ and click **OK** to create a Surface which defines the upper footway.

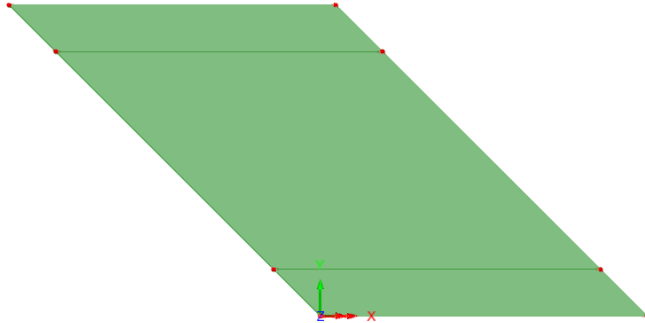

Defining a Surface Mesh

A 3D Thick shell surface mesh is provided by the startup template. To assign the mesh to the model all features must be selected:

- Select all the features of the model, (press the **Ctrl** and **A** keys at the same time).
- Drag and drop the Surface mesh attribute **Thick shell, linear order** from the  Treeview onto the selected features.

The mesh will be displayed with each Line being split according to a default number of divisions specified for each line.





Note. One way of controlling the mesh density is by specifying the number of mesh divisions along each Line. Since Modeller is fully associative, this will control Surface mesh density.

Using Line Mesh Divisions

In this example 8 divisions per Line are required for the longitudinal Lines and transverse Line representing the carriageway. A number of Line mesh divisions are defined by default. These can be seen in the  Treeview.

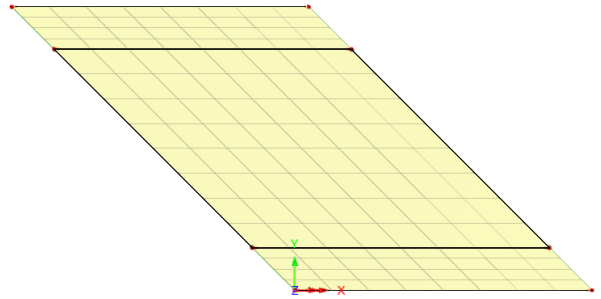
- Select the 4 longitudinal Lines as shown. Hold the **Shift** key down after selecting the first Line to add the other Lines to the selection.
- Still holding the **Shift** key, select the 2 transverse Lines of the middle surface representing the carriageways.



- Drag and drop the Line mesh attribute **Null, div = 8** from the  Treeview onto the selected features.

The mesh will be re-displayed to show 8 mesh divisions along each selected line.



Note. Holding down the **L** key while selecting features ensures that only lines will be selected. Similarly, the **P** key limits the selection to Points, the **S** key; Surfaces, the **V** key; Volumes and the **G** key; Geometry. Similar shortcuts exist for elements, nodes, etc., which can be found in the Online Help.

Defining the Slab Thickness and Eccentricity

The slab is 0.5 m thick in the carriageway region and 0.4 m thick beneath the footways.

| | |
|------------|---|
| Attributes | |
| Geometric | > |
| Surface... | |

- Enter a thickness of **0.5** and leave the eccentricity field empty.
- Enter the attribute name as **Thickness 0.5**
- Click the **Apply** button to define the first geometry attribute and allow another dataset to be defined.
- Change the thickness to **0.4**

Simple Slab Deck

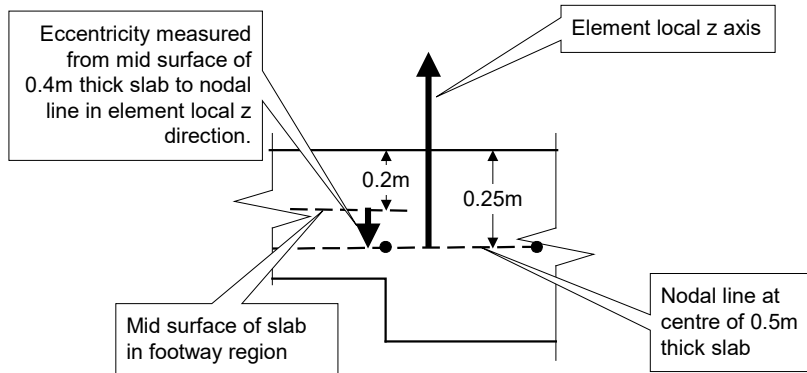

Note. The direction of the eccentricity is measured from the mid-surface of the slab to the nodal line in the local element direction which follows the local surface direction. Since in this example the mid-surface of the slab representing the footway is above the nodal line, and the element local Z axis direction is vertically up, the eccentricity is input as negative.

- Enter the eccentricity as **-0.05**
- Change the attribute name to **Thickness 0.4**
- Click the **OK** button to finish.

The thickness is now assigned to each Surface.

- Select the central Surface representing the carriageway.
- Drag and drop the geometry attribute **Thickness 0.5** from the  Treeview onto the selected surface. Click **OK** to assign to the selected features for Analysis 1.

Geometric assignments are visualised by default.

- Select the outer two footway Surfaces, (hold down the **Shift** key to add the second Surface to the selection).
- Drag and drop the geometry attribute **Thickness 0.4** from the  Treeview onto the selected surfaces. Click **OK** to assign to the selected features for Analysis 1.



Select the isometric button to see the geometric visualisation on the members.



The Zoom in button can be used to check the eccentricity has been assigned correctly.



Select the Home button to return the model to the default view.



Select the fleshing on/off button to turn-off the geometric visualisation

Supports

The more common types of support are provided in the Treeview by default. In this example the slab deck is to be restrained in the vertical and lateral direction at the abutment edges, Additionally, a single pinned support will be assigned to one point on the deck to prevent rigid body motion.

Before the supports can be assigned a local coordinate system needs to be defined so the lateral displacement can be restrained in the skew direction along the length of the abutment edges.

Attributes

Local Coordinate...

- Enter an angle of **45** for the rotation about the **Z-axis**.
- Enter the dataset name as **Skew** and click **OK** to add the Local coordinate attribute to the Treeview.

By default the new **Skew** local coordinate system, is visualised within the view global axes.

To assign the abutment supports:

- Select the six transverse Lines representing the end diaphragms (ensure the **Shift** key is used to add to the initial selection)
- Drag and drop the local coordinate attribute **Skew** onto the selected Lines.
- Drag and drop the support attribute **Fixed in YZ** onto the selected Lines.

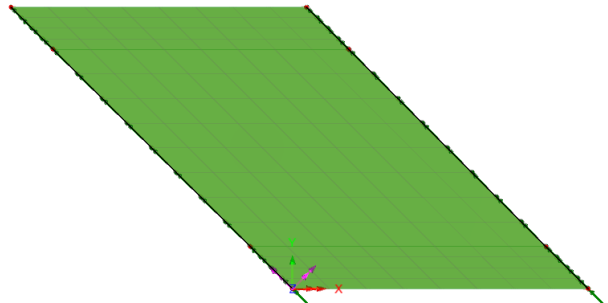

The Assign Support dialog will be displayed.

- Ensure that the attribute is assigned to **All analysis loadcases**
- Click the **OK** button to finish.

Simple Slab Deck

To assign the pinned support:

- Select the single Point at the x,y,z axis origin
- Drag and drop the support attribute **Pinned** onto the selected Point.

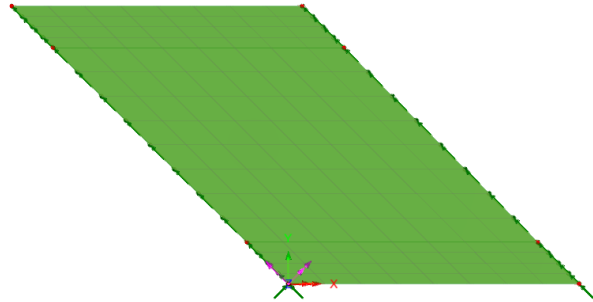

The Assign Support dialog will be displayed.

- Ensure that the attribute is assigned to **All analysis loadcases**
- Click the **OK** button to finish.



Note. Since the slab is flat the in-plane rotation degrees of freedom for the thick shell elements can be eliminated from the element formulation by deselecting the following element option. This will remove ill-conditioning of the equations and reduce the problem size. It should however be noted that if moment supports are to be applied with this option deselected, rotation about the Z axis must be restrained to eliminate mechanisms in the solution.

- Select the **Options** tab and select the **Element Options** button. Deselect the option to **Assign 6 DOF to all thick shell element nodes** and click the **OK** button to return to the Model Properties. Click **OK** to return to the display.

Defining the Loads

Four loadcases will be defined:

- The self-weight of the slab (ignoring any surfacing loads).
- A patch load equivalent to a traffic load over the full length and width of the upper traffic lane.
- A knife edge load acting at mid-span of the upper lane.
- An HB vehicle in the lower lane.

Self-weight

The self-weight is defined using acceleration due to gravity in the negative Z direction. A body force loading attribute representing gravity is provided by the startup template. This will be assigned to the model shortly.

File
Model Properties...

Lane Load

Bridge
 Bridge Loading >
 United Kingdom...

The second load will represent a lane load along the upper traffic lane.

- From the Vehicle Loading dialog select the **Lane load (HA Load)** button.
- Select loading code **BD37/88** from the pull-down list.
- Enter the loaded length as **10.5**, leave the notional width as **3.5**, set the skew angle as **-45** and the origin as **Centre**, then click **OK** to add the lane load patch loading to the .

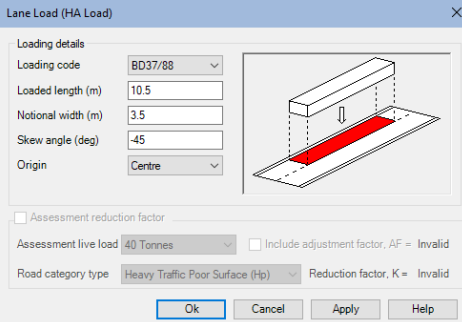



Note. Setting a skew angle on this patch load does not skew the whole load – it only skews the ends of the patch load to match the angle of the skewed deck.

Knife Edge Load

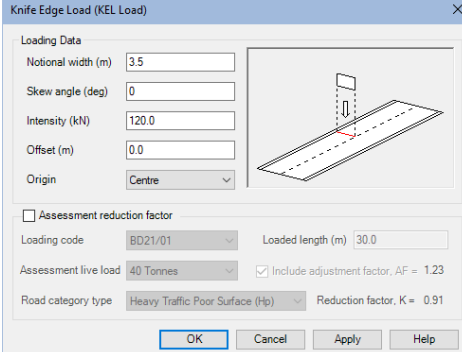
- From the Vehicle Loading dialog select the **Knife edge load (KEL load)** button.
- Leave the skew angle as **0** and click **OK** to add the lane load patch loading to the .



Abnormal Loading

- From the Vehicle Loading dialog select the **Abnormal Load (HB Vehicle)** button.
- Leave the **Axle spacing** as **6** and the **Number of HB units** as **45** and click **OK** to add the HB vehicle point load to the .

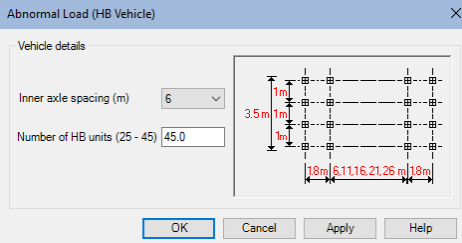

- Select **Close** to close the Vehicle Loading dialog.

Assigning the Self-weight Load

- To assign the gravity loading select all active features using the **Ctrl + A** keys together and drag and drop the loading attribute **Gravity vertical** from the  Treeview onto the selected features.

The Loading Assignment dialog will be displayed.

- Ensure that the **Assign to Surfaces** button is selected and click the **OK** button to assign the load to **Analysis 1, Loadcase 1**.

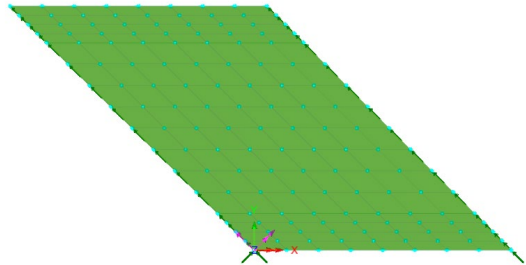



The load visualisation for Loadcase 1 will be displayed.

- To rename Loadcase 1 in the  Treeview expand **Analysis 1** and select **Loadcase 1** with the right-hand mouse button, then choose the **Rename** option. Overtyp the loadcase name with the name **Self Weight**

Assigning the Lane Load and Knife Edge Loads

Lane loads and vehicle loads are represented by patch loads that are assigned to Points which may form part of the model, or may be defined specifically to locate the bridge loads as in this case:

 Enter coordinates as **(-1.5, 6.75)** and click the **OK** button to create a new Point in the middle of the upper lane.

 Temporarily turn off the display of the loading so that the point defined can be seen.

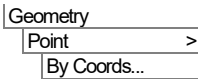

The patch and knife edge loads can now be assigned to the Point that has just been defined.

- Select the **Point** defined at the centre of the upper traffic lane.
- Drag and drop the loading attribute **Pch2 (HA BD37/88 10.5m x 3.5m Skew= -45.0deg (Centre))** from the  Treeview onto the selected Point.

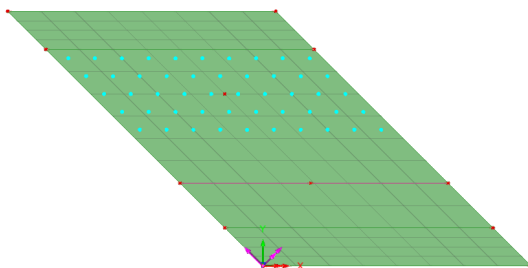

The Loading Assignment dialog will appear.

The loading option to **Project over area** will have been automatically selected.

- Overtyp the name of the loadcase to be **HA & KEL upper**
- Click **OK** to complete the assignment.



Turn on the display of loading.

The patch load will be visualised on the model.

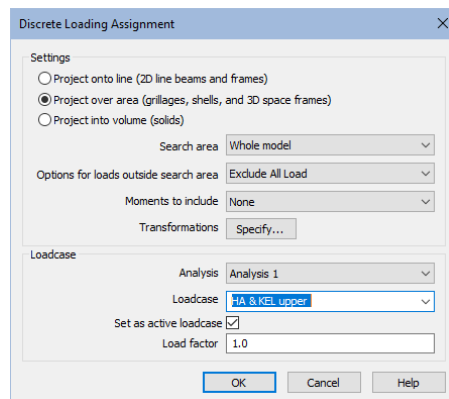

Note. The number of patch load divisions in the patch is set in the  Patch divisions object. By default ten patch divisions are used in the long direction of the entire patch. For more detailed information on discrete point and patch loads refer to the on-line help.

- With the Point defined at the centre of the upper traffic lane still selected, drag and drop the loading attribute **Pch3 (KEL 120kN Width=3.5m Offset=0 Skew=0.0deg (Centre))** from the  Treeview onto the selected Point.

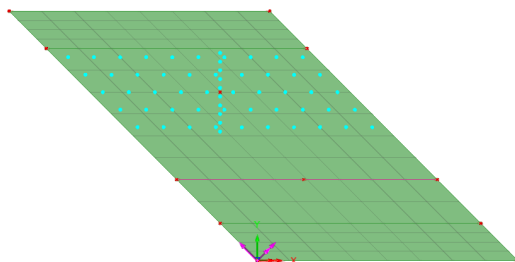

Simple Slab Deck

- Select the loadcase name **HA & KEL upper** from the loadcase droplist and click the **OK** button to assign the load.

The assigned patch loading for the upper lane should be as shown.



Note. In this example the patch loading has been shaped to match the skew of the deck, but it could have alternatively been defined oversize in length and when assigned to the model any loading outside of the model could have been excluded as necessary.



If rebuilding a model or creating a model using the supplied file.

If a previous analysis of this example has failed, you need to return to this point to continue after having run the supplied file stated.

If you created the model using the supplied associated file, you need to continue from this point to complete the modelling required.

Assigning the Moving HB Vehicle Load

The HB vehicle will be assigned to the points using the moving load generator. To use this facility a line defining the path of the vehicle must be created.

- Click on an empty region of the model view window to clear the current selection.



Enter coordinates of **(-3.25, 3.25)** and **(7.25, 3.25)** to define a Line describing the path of the HB vehicle and click **OK**.

Geometry
Line >
By Coords..

Bridge
Moving Load
Analysis...

- Select the **Line** just defined.
- Ensure the discrete load is set to **Pnt4: (HB 6.0m spacing 45.0 units)**.
- Ensure that ‘Options for loads outside search area’ is set to **Exclude All Load**.
- Ensure that ‘Moments to include’ is set to **None**.
- Set the option ‘Move vehicle along path in equal number of divisions’ to **10**.
- Ensure that **Create loadcase envelope** is selected and click **OK**.

Loadcases 3 to 13 that represent the HB load moving forward across the bridge will be generated in the  Treeview along with a maximum and minimum load envelope.

Checking loading

Loads on the model may be visually checked at any time by changing the active loadcase.

- From the  Treeview select **Loadcase 6 (s=5.25m)**, click the right-hand mouse button and select the **Set Active** option to see the mid-span position of the moving load.

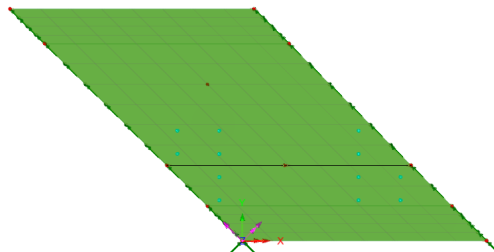

This process may be repeated for any loadcase, and the isometric view button  can be used to rotate the model so the load directions can be seen.

Saving the Model

The model is now complete. The model data should be saved before running the analysis.

File
Save



Save the model file.

Running the Analysis

With the model loaded:



Press the **Solve Now** button to run the analysis.

A LUSAS Datafile will be created from the model information. The LUSAS Solver uses this datafile to perform the analysis.

If the analysis is successful

Analysis loadcase results are added to the Treeview.

In addition, these files will be created in the LUSASFiles32\<<model_name> folder:



- bridge_slab.out** this output file contains details of model data, assigned attributes and selected statistics of the analysis.
- bridge_slab.mys** this is the LUSAS results file which is loaded automatically into the Treeview to allow results processing to take place.

If the analysis fails...

If the analysis fails, information relating to the nature of the error encountered can be written to an output file in addition to the text output window. Any errors listed in the text output window should be corrected in LUSAS Modeller before saving the model and re-running the analysis.

Rebuilding a Model

If it proves impossible for you to correct the errors reported a file is provided to enable you to re-create the model from scratch and run an analysis successfully. You may download this file from the user area of the LUSAS website.



- bridge_slab_modelling.lvb** carries out the modelling of the example.



Start a new model file. If an existing model is open Modeller will prompt for unsaved data to be saved before opening the new file.

- Enter the file name as **bridge_slab**
- Use the default **User-defined** working folder.
- Ensure an Analysis category of **2D Inplane** is set.
- Click the **OK** button.



Note. There is no need to enter any other new model details when a script is run to build a model, since the contents of the script will overwrite any other settings made.

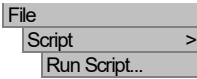

- To recreate the model, select the file **bridge_slab_modelling.lvb** that was downloaded and placed in a folder of your choosing.

Now return to the section entitled **Assigning the Moving HB Vehicle Load** earlier in this example and continue from this point.

Viewing the Results

Loadcase results can be seen in the  Treeview, and the loadcase results for the last solved loadcase is set active by default.

The results will be examined. For this problem the following are required:

- A plot of the deformed mesh.
- A contour plot of bending moments in the X direction due to a load combination.
- A graph showing the variation of bending moment along a section of the slab.
- A contour plot of Wood-Armer reinforcement moments in the slab.

Using Page Layout Mode

The model was created using a Working Mode view which allows a model of any size to be created. Results could be viewed using this mode of operation, but in order to allow additional information to be added without obscuring the model, Page Layout Mode could be used instead.





The graphics window will resize to show the model on an A4 size piece of paper in landscape orientation.



- Ensure that left, right top and bottom margins are set to **60, 10, 10** and **10** respectively and click **OK**

Displaying the deformed shape

The deformed mesh layer initially provided in the  Treeview by the startup template is turned on following a successful solve of the model. To see just the deformed mesh of the model the Mesh, Attributes and Geometry layers will be turned off.

- In the  Treeview, click the right-hand mouse button on the **Mesh** entry and turn off the **Display** option. The mesh layer will be hidden from the display.
- Repeat to turn off the **Attributes** and **Geometry** layers.



If necessary, use the Isometric view button to rotate the model to the view shown.

Set the active loadcase

- In the Treeview right-click on **Self Weight** and select the **Set Active** option.



Note. If ever required, the local coordinate system axes can also be turned off by deselecting the **Show Definition** option for the **Skew** entry in the Treeview.

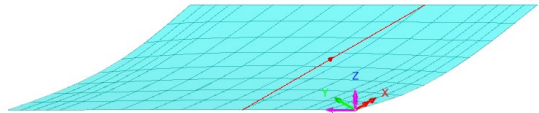

Saving a view

This page layout view can be saved for subsequent re-use with other models.

Enter the view name as **Landscape Page Layout** and click **OK**



Contour Plots

Results can be plotted as colour line or filled contour plots. Here, longitudinal bending moments will be plotted as colour filled contours.

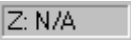
 Return the model to the default starting view by pressing the Z axis field on the status bar at the bottom of the graphics window.

- With no features selected click the right-hand mouse button in a blank part of the graphics window and select the **Contours** option to add the contours layer to the Treeview.

The contours properties dialog will be displayed.

- Select Entity **Force/Moment**
Component moments in the X direction **M_x**
- Click the **OK** button to display contours of moments in the X direction.

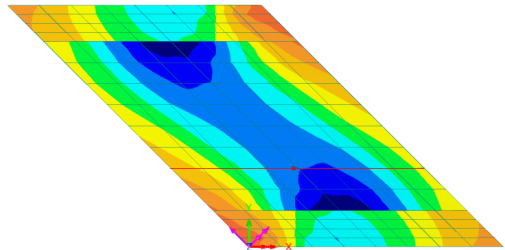



Note. By default in LUSAS Modeller, averaging of results is done for all situations where it is appropriate. When it is inappropriate (as in this case where different geometric thickness assignments have been made) no averaging of results across those element boundaries takes place.

Moving information on the annotation layer

Text and other objects such as the contour key may be moved after their initial placement.

- Click on one of the items of text on the contour key. (This will select the key and enable it to be moved).
- Click and drag the object to a new position on the left-hand margin of the page.

Marking Peak Values

- With nothing selected click the right-hand mouse button in a blank part of the graphics window and select the **Values** option to add the values layer to the  Treeview.

The values properties dialog will be displayed.

- Select **Force/Moment** contour results of bending moment **Mx**
- On the same dialog, select the **Values Display** tab and ensure the **Maxima** and **Minima** check boxes are selected to display the top 1% of results.
- Set the number of significant figures to 4
- Change the angle to 45 degrees.
- Select the **Choose Font** button and set the text size to 16 and click **OK**

Simple Slab Deck

- Click the **OK** button to add the extreme maximum and minimum values to the display.

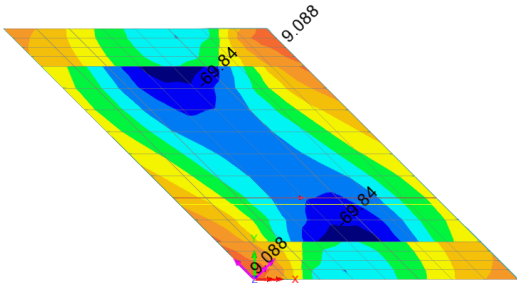

If necessary, the values can be seen in isolation by turning the contours layer off and then on again.



Defining a Combination

Combinations can be used to view the combined effects of several results loadcases, combinations or envelopes.

The combination properties dialog will appear. Loadcases Self Weight, HA & KEL upper and the moving load envelope are to be included in the combination.

- With **Analysis 1** expanded in the Available list select both **Self Weight** and **HA & KEL upper** from the Name panel and click the  button to add the loadcases to the combination dataset with a factor of **1**
- With Post processing expanded in the Available list select the envelope **Envelope (Static Moving Load Analysis 1) (Max)** and click the  button to add the loadcase to the combination dataset.



Note. By default loadcases are added to the combination with a factor of 1. This factor may be changed by selecting the loadcase in the Included panel and changing the load factor in the grid provided.

- Change the combination name to **Max Design Combination** and click the **OK** button to finish.



Note. To obtain the correct effect from the combined loads the combination should only include one occurrence of each loadcase. Envelope and Combination definitions are held and saved within the model file.



Note. Changing the properties of the max or min envelope will change the definition of both envelopes.

Selecting and Viewing the Combination Results

- In the  Treeview right-click on **Max Design Combination** and select the **Set Active** option.
- Select **Force/Moment** results of component **Mx** and click **OK**



Note. When a combination includes an envelope the deformed mesh layer is not available.

The contour plot for Mx from the load combination will be displayed.

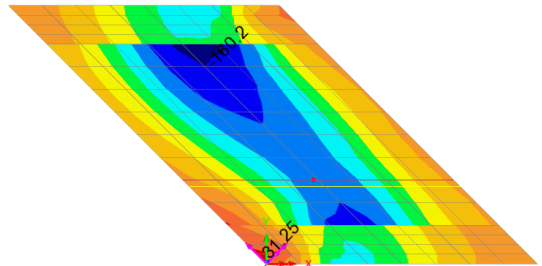

Note. The values layer is still listed in the  Treeview so the maximum and minimum values of Mx for the load combination will also be shown.

Graphing the Results of a Slice

A graph is to be plotted showing the variation in bending moment through a specified section of the slab.

Utilities
Graph Through 2D

If the model is being viewed in the XY plane (as it is) the **By Cursor** option will be selected and the **Snap to grid** option will be available.

- Ensure that **Snap to grid** is selected with a grid size of **1**
- Click the **OK** button.
- Click and drag the cursor along the centre of the lower lane (Y=3) to define the location of a section slice through the slab.

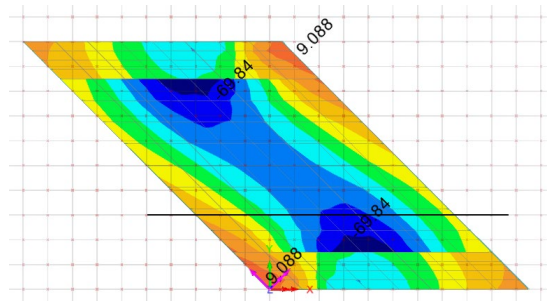

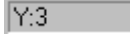
Note. The Y ordinate of the slice can be seen in the status bar . The X and Y scales on the sides of the window will also help this selection.

The graph X axis values of distance through the deck are defined by the slice section. The graph Y axis results now need to be specified on the slice data dialog.

Simple Slab Deck

- On the Loadcases and Extent dialog ensure that Max design Combination is selected and click **Next**.
- On the Slice Data dialog select **Force/Moment** results for Bending Moment in the X direction **Mx** and click the **Next** button.

The graph Y axis results have now been defined and title information for the graph can be added.

- Enter the graph title as **Bending Moment Mx along lower lane**
- Leave the graph X and Y axis names blank.
- Click the **Finish** button to display the graph.

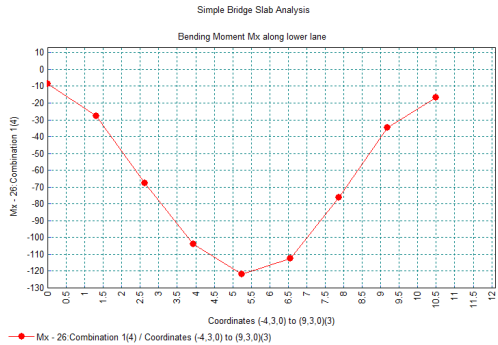

Note. If the graph axes labels are left unspecified default names will be used. The graph properties can be modified by clicking the right hand mouse button in the graph window and selecting the Edit Graph Properties option.



Close the graph window.



Click on the selection mode button to return to normal cursor mode.

Save the model



Save the model file.



Note. When the model file is saved after results processing, all load combinations, envelopes, and graph datasets, if defined, are also saved and therefore do not have to be re-created if the model is amended and a re-analysis is done at a later date.

This completes the example.

Discussion

Use of an irregular mesh and transformation of results

In this example the geometry and mesh attributes result in a regular mesh aligned to the global axis.



Caution. The use of an irregular mesh would mean that the results obtained would have different orientations over the whole slab and hence be incorrect. In this circumstance a local coordinate set would need to be used to orientate the element results to be consistent with the global axes in order to obtain sensible components for use in the calculations.

- A local coordinate set can be created by selecting **Attributes > Local Coordinate**.
- The mesh orientation can be viewed from the  Treeview by selecting **Mesh > Properties** and selecting the **Show Element Axis** option. Press **OK** to apply changes.
- Results transformations can be applied by visiting a results layer's properties dialog and pressing the **Set...** button.

