

Heat of hydration modelling of a concrete base slab

| | |
|--------------------------|--|
| For LUSAS version: | 24.0 |
| For software product(s): | Any Plus version |
| With product option(s): | Nonlinear, Dynamic, Heat of Hydration. |

Description

A concrete base slab has a length of 40m, a width of 20m and a height of 3m. For the purposes of this example it is assumed to be cast in one pour.

The temperature effects from modelling casting the slab with a constant ambient temperature and a varying ambient temperature are investigated on a quarter model of the slab, as shown coloured in grey in the adjacent image. Side formwork is modelled as being present from 0 to 3 days and then removed for the duration of the investigation.

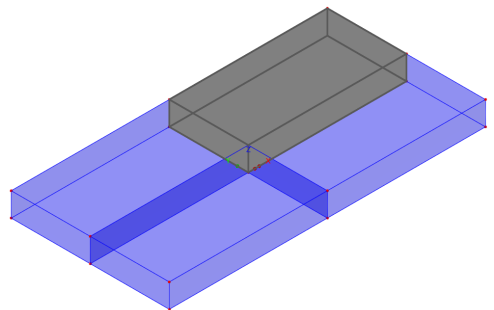

Units used are N, m, kg, s, C throughout.

Objectives

The required output from the analysis consists of:

- A graph showing temperature against response time for a selected location within the slab for the ambient temperature conditions investigated.

Keywords

3D, Slab, Concrete, Heat of Hydration, Loadcase, Load curve, Temperature, Graphing.

Associated Files



- slab_HHC_modelling.lvb** carries out the modelling for Analysis 1 – constant ambient temperature.
- slab_HHC_loadcurves.lvb** carries out the modelling for Analysis 1 and Analysis 2 – varying ambient temperature.

Analysis 1 – Constant ambient temperature

Running LUSAS Modeller

For details of how to run LUSAS Modeller see the heading *Running LUSAS Modeller* in the *Introduction to LUSAS Worked Examples* document.



Note. This example is written assuming a new LUSAS Modeller session has been started. If continuing from an existing Modeller session select the menu command **File>New** to start a new model file. Modeller will prompt for any unsaved data and display the New Model dialog.

Creating a new model

- Enter a file name of **Slab_HHC**
- Use the default **User-defined** working folder.
- Set analysis type to be **Thermal**.
- Set the analysis category to be **3D**.
- Set modelling units to be **N,m,kg,s,C**.
- Set timescale units of **Days**.
- Enter a title of **Heat of hydration modelling of a concrete slab**
- Click the **OK** button.

Defining the slab geometry

File
New...

Geometry
Shape Wizard...

- Select a **Cuboid** shape of type **Volume** and click **Next**.
- Enter a length in X of **20**, in Y of **10** and in Z of **3** and click **Finish**.
-  Press the isometric button to view the volume model generated.

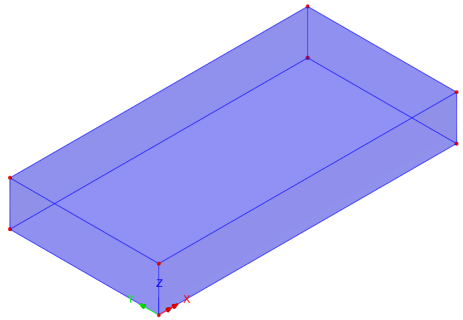

Defining and assigning the mesh

- Ensure Element type is set to **Field**, Shape is **Hexahedral** and Interpolation order is set to **Quadratic**.
- Deselect the **Automatic** divisions checkbox and enter divisions in x, y and z of **16**, **10** and **8** respectively, and click **OK**.

With the whole model selected:

- From the  treeview drag and drop the mesh attribute **Vmsh1** onto the model.
- Click in an empty region of the view window to deselect the selection and view the mesh.

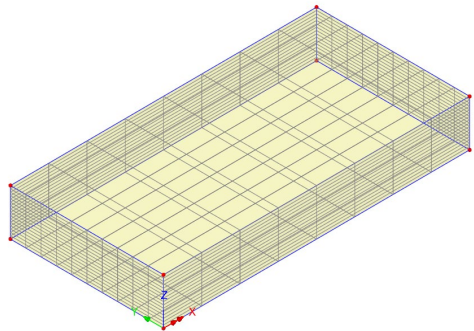

Defining and assigning the material properties

- On the Thermal tab enter a Thermal conductivity of **2**, a Specific heat capacity of **1.0448E3** and a Density of **2400** – noting that the units in use for each can be seen when hovering over the cells.
- In the Exothermic behaviour section of the dialog select **Concrete Heat of Hydration**.
- Select the ‘Cement Type’ to be **Type I**, define the ‘Mass of cement per unit volume’ to be **307** and enter a ‘Water/Cementitious mass ratio’ of **0.47** and click **OK**.

With the whole model selected:

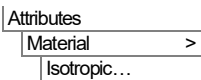
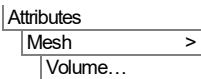



Heat of hydration modelling of a concrete base slab

- From the  treeview drag and drop the material attribute **ISO1** onto the model, assigning it to **Volumes** for **All analysis loadcases**. Click **OK**.

Defining the temperature loading

- Select **Prescribed** and click **Next**.
- Ensure that **Total, Fixed**, temperature loading of **20** degrees is specified to represent the stress-free ambient temperature. Enter a name of **Initial Temp** and click **Finish**.

With the whole model still selected:

- From the  treeview drag and drop the loading attribute **Initial Temp** onto the model, assigning it to **Volumes** for **Loadcase 1**. Click **OK**.
- In the  Treeview, rename Loadcase 1 to be **Initialisation**

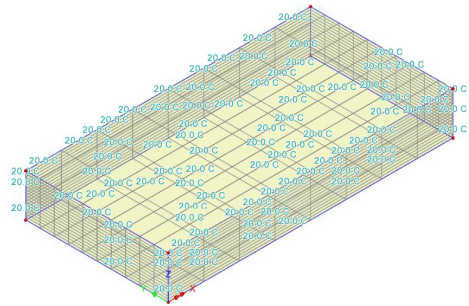

Defining and assigning the supports

- Select **Free**, enter a name of **Free** and click **OK**.

With the whole model still selected:

- From the  treeview drag and drop the support attribute **Free** onto the model assigning it to **Volumes**. Select the **From loadcase** radio button and type **Formwork for 3 days** into the loadcase field to create a new loadcase. Click **OK**.



Note. This frees up the temperatures from the prescribed temperature loading which “locked” the temperatures in the Initialisation loadcase.

Defining environmental conditions



These will define the ambient temperatures and rate of heat transfer on the faces of the volume. Any face not assigned environmental conditions will be treated as an internal concrete face, i.e. a mirror plane.

- Select **Environmental conditions** and click **Next**.
- Untick the **Temperature dependent** checkbox.

- Enter an Environmental temperature of **20** and a Convection heat transfer coefficient of **2.777**. Enter a name of **Face Ground Temperature** and click **Apply**.
- Leaving the environmental temperature set to **20**, change the convection coefficient to be **8.333**. Change the name to be **Face Air Temperature** and click **Apply**.
- Lastly, leaving the environmental temperature set to **20**, change the convection coefficient to be **7**. Change the name to be **Face Formwork Temperature** and click **Finish**.
- Click in an empty region of the view window to deselect the volumes selected.



Assigning environmental conditions

Side faces

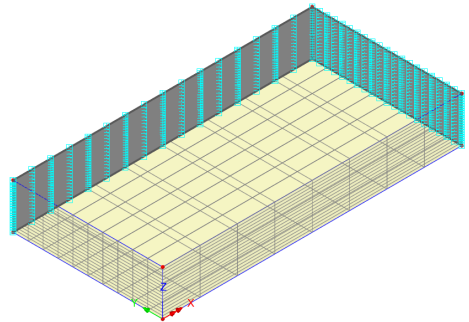
- Select the two outer vertical faces of the base slab.
- From the  treeview, drag and drop the **Face Formwork Temperature** onto the selection assigning it to the loadcase **Formwork for 3 days**.
- From the  treeview, drag and drop the **Face Air Temperature** onto the selection and assigning it to a new loadcase by over-typing the name with **Exposed until 30 days**.



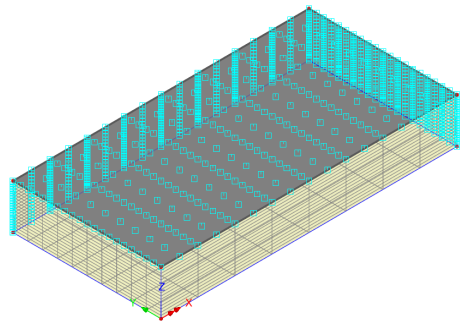

Top face

- Select the top face of the slab.
- From the  treeview, drag and drop the **Face Air Temperature** onto the selection assigning it to the loadcase **Formwork for 3 days**.
- From the  treeview, drag and drop the **Face Air Temperature** onto the selection and assigning it to the loadcase **Exposed until 30 days**.



Bottom of slab

- Select the bottom face of the slab.
- From the  treeview, drag and drop the **Face Ground Temperature** onto the selection assigning it to the loadcase **Formwork for 3 days**.
- From the  treeview, drag and drop the **Face Ground Temperature** onto the selection assigning it to the loadcase **Exposed until 30 days**.

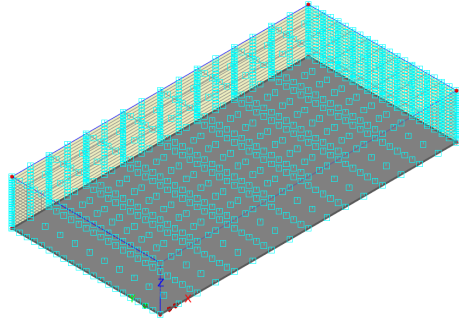

Define nonlinear and transient controls

'Initialisation' loadcase

- In the  Treeview, right-click on the **Initialisation** loadcase and select **Controls** then **Nonlinear and transient**.
- In the Incrementation section tick **Nonlinear** to turn it on.
- Select **Time Domain**, enter an initial timestep of **1e-3**, a total response time of **1e-3**, a maximum number of time steps of **1**, and click **OK**.

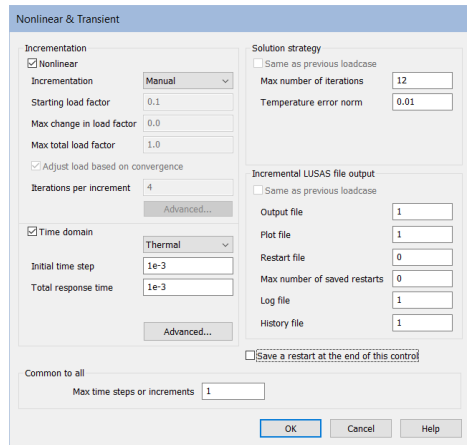

The screenshot shows the 'Nonlinear & Transient' dialog box with the following settings:

- Incrementation**
 - Nonlinear
 - Incrementation: Manual
 - Starting load factor: 0.1
 - Max change in load factor: 0.0
 - Max total load factor: 1.0
 - Adjust load based on convergence
 - Iterations per increment: 4
 - Advanced...
- Time domain**
 - Time domain
 - Time domain: Thermal
 - Initial time step: 1e-3
 - Total response time: 1e-3
 - Advanced...
- Solution strategy**
 - Same as previous loadcase
 - Max number of iterations: 12
 - Temperature error norm: 0.01
- Incremental LUSAS file output**
 - Same as previous loadcase
 - Output file: 1
 - Plot file: 1
 - Restart file: 0
 - Max number of saved restarts: 0
 - Log file: 1
 - History file: 1
- Save a restart at the end of this control
- Common to all**
 - Max time steps or increments: 1
- Buttons: OK, Cancel, Help

'Formwork for 3 days' loadcase

- In the  Treeview, right-click on the **Formwork for 3 days** loadcase and select **Controls** then **Nonlinear and transient**.
- In the Incrementation section tick **Nonlinear** to turn it on.
- Select **Time Domain**, enter an initial timestep of **0.05**, a total response time of **3**

- Click the **Advanced** button and change the Time step increment factor to **1.25** and click **OK**. Then **OK** again to exit the main dialog.

'Exposed for 30 days' loadcase

- In the  Treeview, right-click on the **Exposed until 30 days** loadcase and select **Controls** then **Nonlinear and transient**.
- In the Incrementation section tick **Nonlinear** to turn it on.
- Select **Time Domain**, enter an initial timestep of **0.5**, a total response time of **30**
- Click the **Advanced** button and change the Time step increment factor to **1.25** and click **OK**. Then **OK** again to exit the main dialog.

The model is now complete.

Turn off the display of the loading



Press the loading on-off button to turn off the loading.



Save the model



Save the model file.

File
Save

Checking the Attributes and Analyses Treeviews

The Attributes  Treeview and the Analyses  Treeview now contain all the information for an analysis to be carried out.

For a successful analysis your model should contain treeviews similar to those that follow. Right-clicking on attribute and loadcase data allows any defined values to be checked. If your model has potential errors in your Attribute data, or in your Loadcase assignments that you cannot fix, a file is provided to enable you to re-create the model from scratch and run the analysis successfully.



Note. The thermal loadcases are always tabulated and solved in  Treeview order from top to bottom.

Attributes treeview

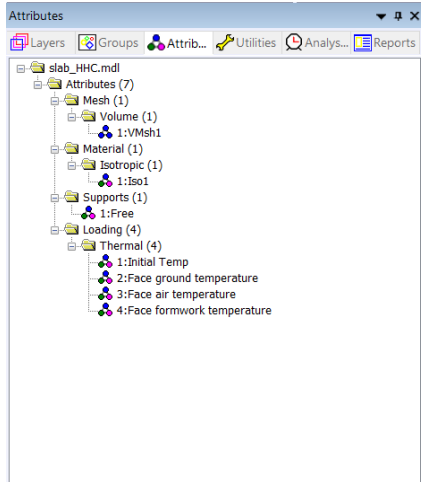

Analyses treeview

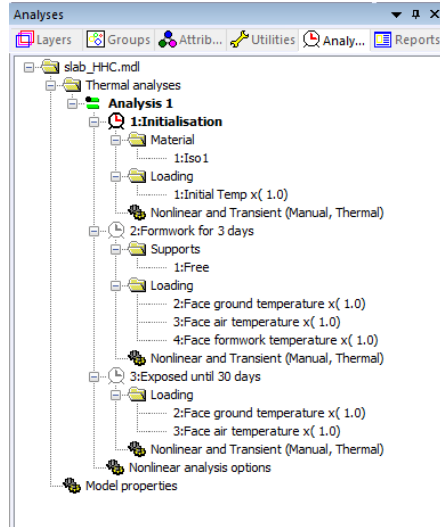

Running the Analysis

With the model loaded:



Open the **Solve Now** dialog.

- Ensure that the **Analysis 1** is selected and press **OK** to run the analysis.

A LUSAS datafile will be created from the model information. The LUSAS Solver uses this datafile to perform the analysis.

If the analysis is successful...

Analysis loadcase results are added to the  Treeview.

Associated files will be created in the LUSASFiles\<<model_name> folder.

If the analysis fails...

If the analysis fails, information relating to the nature of the error encountered is written to an output file in addition to the text output window. Any errors listed in the text output window should be corrected in LUSAS Modeller before saving the model and re-running the analysis.

Rebuilding a Model

If it proves impossible for you to correct the errors reported the following file is provided to enable you to re-create the model from scratch and run an analysis successfully:



- slab_HHC_modelling.lvb** carries out the modelling this first part of the example ready for an initial solve to be undertaken.

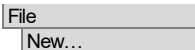

Start a new model file. If an existing model is open, Modeller will prompt for unsaved data to be saved before opening the new file.

- Enter the file name as **slab_HHC**
- Select units of **N,m,kg,s,C**
- Ensure the **Thermal** user interface is selected and click the **OK** button

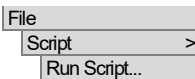

- To recreate the model, open the file **slab_HHC_modelling.lvb** that was downloaded and placed in a folder of your choosing.



Run the analysis to generate the results.

Viewing the Results

Analysis results for each time step are present in the Treeview. The time step result for the last thermal loadcase to be solved (Time = 30.0000) is set active by default.

Plotting contours of temperature after 3 days

- In the Treeview, in the **Formwork for 3 days** analysis, set active the loadcase **Time Step 14 Time = 3.000**
- With no features selected click the right-hand mouse button in a blank part of the Graphics window and select **Contours...**
- Ensure that Entity **Temperature** and Component **Temp** and **Nodal** results are selected.

A plot showing the temperature distribution at 'Time = 3 days' will be displayed.

Heat of hydration modelling of a concrete base slab

Analysis: Analysis 1
Loadcase: 2:Formwork for 3 days, 15:Time Step 14 Time = 3.00000
Results file: slab_HHC-Analysis 1.mys
Response time: 3.0
Entity: Temperature
Component (Nodal): Temp (Units: C)

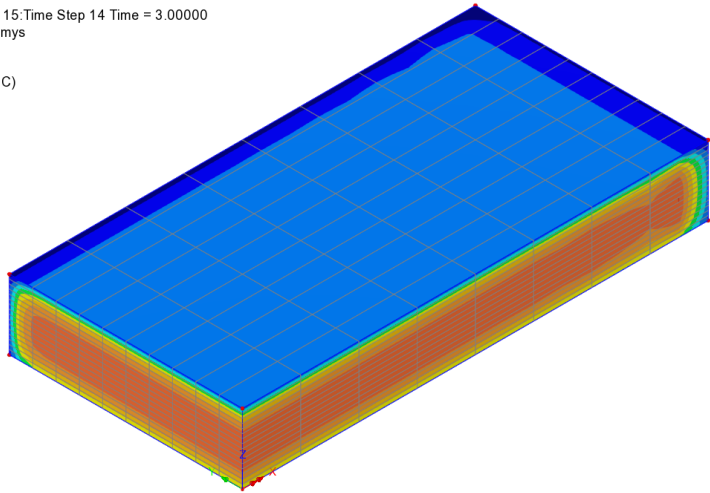
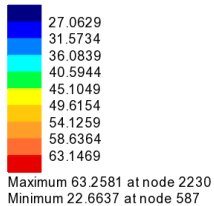

Change the contour range

- In the  Treeview, double click the **Contours** entry. On the properties dialog, click the **Appearance** tab and choose the **Set** button adjacent to the Classic contour option to set the maximum and minimum contour values to **60** and **20** respectively. Click **OK** to return to parent dialog and **OK** again to finish.

Analysis: Analysis 1
Loadcase: 2:Formwork for 3 days, 15:Time Step 14 Time = 3.00000
Results file: slab_HHC-Analysis 1.mys
Response time: 3.0
Entity: Temperature
Component (Nodal): Temp (Units: C)

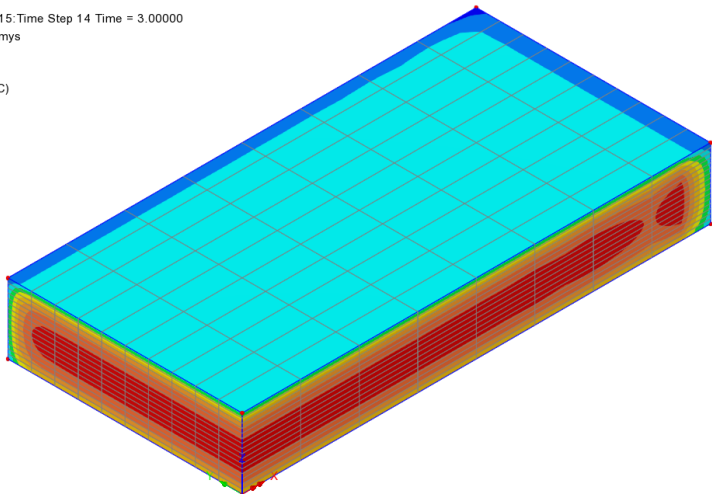
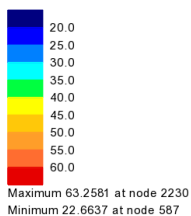



Note. Setting a fixed contour range is useful when wanting to view a consistent set of colours for a range of temperatures, and when animating load increments (not done in this example).

Plotting contours of temperature after 30 days

- In the  Treeview, in the **Exposed until 30 days** analysis, set active the loadcase **Time Step 26 Time = 30.000**

Analysis: Analysis 1
 Loadcase: 3.Exposed until 30 days, 27:Time Step 26 Time = 30.0000
 Results file: slab_HHC-Analysis 1.mys
 Response time: 30.0
 Entity: Temperature
 Component (Nodal): Temp (Units: C)

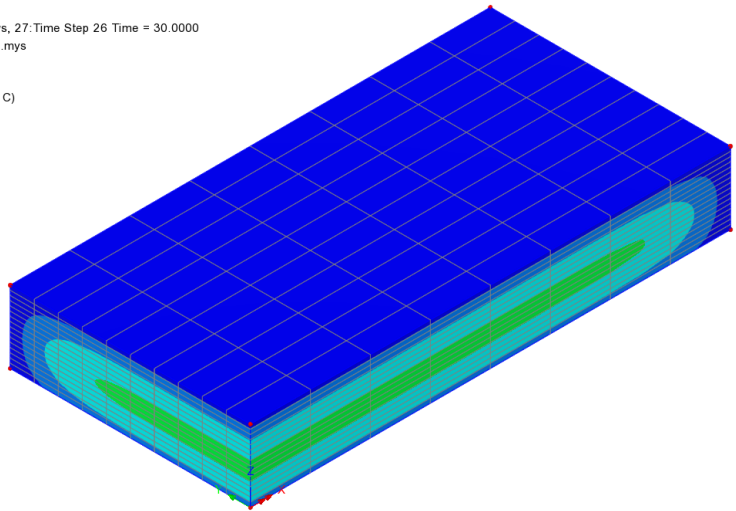
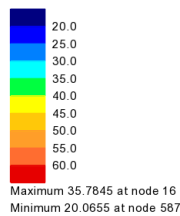

Graphing of temperature at a selected node

- With reference to the adjacent image, select the node in the middle of the slab as highlighted – the one at half height, at the corner between the two internal faces, at coordinates (0,0,1.5). Note that by selecting a point and then hovering the cursor over it its coordinates may be seen.

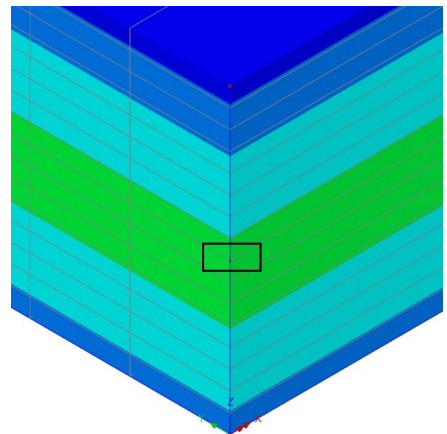

- For the X axis, select **Time history** and press **Next**.
- Select **Named** results for the **Whole Analysis** for **Analysis 1** and click **Next**.
- Select **Response time** and click **Next**.
- For the Y-axis, select **Nodal** and click **Next**.

Utilities
 Graph wizard

Heat of hydration modelling of a concrete base slab

- Select entity **Temperature** and Component **Temp**, for the specified single node and click **Next**.
- Title the graph **Temperature over time of node in middle of slab** and click **Finish**.

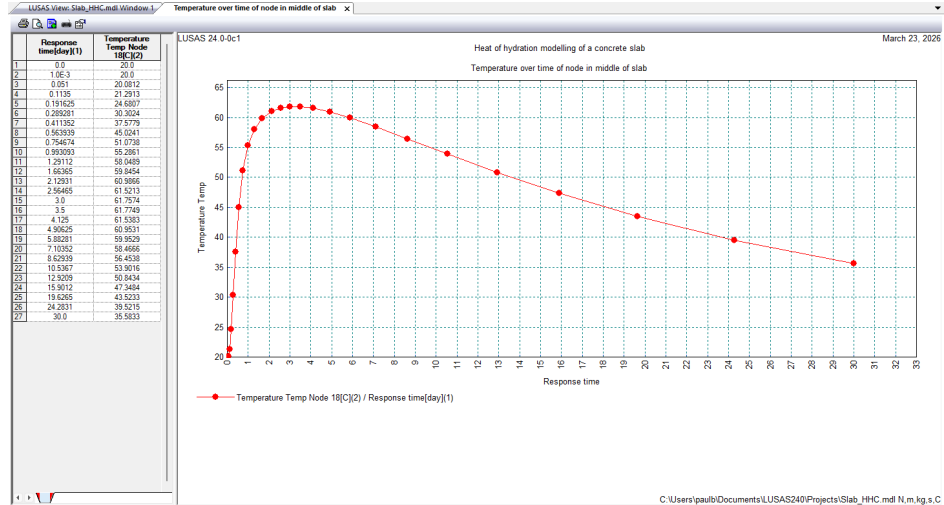

From the table data a peak temperature of 61.8 degrees is achieved after 3.5 days. After this time, the temperature is continually cooling but has not returned to ambient within 30 days.

Analysis 2 – Varying ambient temperature

Varying the ambient temperature using loadcurves

The use of a constant ambient temperature, as done in the previous analysis, is not very realistic. In reality the air temperature will vary between day and night, which will affect the slab temperature. A new analysis (Analysis 2) will be created to show a more realistic modelling approach. Analysis 1 will be retained for reference.

Create a new analysis

- Enter the name to be **Analysis 2 – Day-night variation** and press **OK**.
- Rename the first loadcase in it to be **Initialisation Day-night**

Defining and assigning the supports

With the whole model selected:

Analyses
Thermal Analysis

- From the  treeview drag and drop the support attribute **Free** onto the model ensuring **Assign to volumes** is selected.
- With the ‘From loadcase’ radio button selected for **Analysis 2 – Day-night variation** ensure that a **New** loadcase called **30 days Day-night** is created and click **OK**.



Note. This frees up the temperatures from the prescribed temperature loading which has “locked” the temperatures in the original Initialisation loadcase.

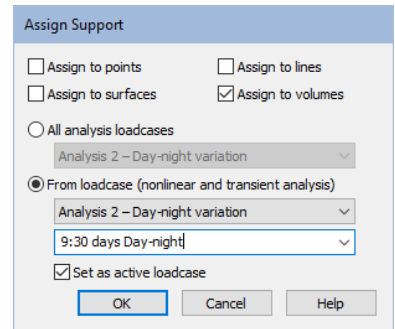

The 'Assign Support' dialog box has the following settings:

- Assign to points
- Assign to lines
- Assign to surfaces
- Assign to volumes
- All analysis loadcases
- Analysis 2 – Day-night variation (dropdown)
- From loadcase (nonlinear and transient analysis)
- Analysis 2 – Day-night variation (dropdown)
- 9:30 days Day-night| (dropdown)
- Set as active loadcase
- Buttons: OK, Cancel, Help

Defining load curves

Load curves can be used to describe the variation of loading with time.

Analyses
Load Curve

- Create a **User-defined** loadcurve by entering a time of **0** and a factor of **1**, then press the **Tab** key to get a new line in the table. Enter a time of **1e-3** and a factor of **1**. (This will give a constant load factor of 1 for time = 0 to time = 0.001 days). Ensure it is in **Analysis 2**, give it a name **Initialisation curve** and click **Apply**.
- Next, change the time in the second row to be **30**, change the name to **Constant curve** and click **Apply**.
- Now select the **Standard curve** option of type **Cosine**, with Amplitude **10**, Frequency **1** and Mean amplitude **20**.

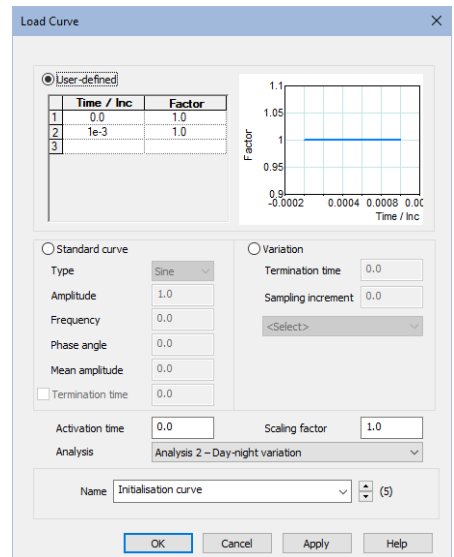

The 'Load Curve' dialog box shows the following configuration:

- User-defined
- Table:

| | Time / Inc | Factor |
|---|------------|--------|
| 1 | 0.0 | 1.0 |
| 2 | 1e-3 | 1.0 |
| 3 | | |
- Graph: Factor vs Time / Inc (0.0 to 0.001)
- Standard curve
 - Type: Sine
 - Amplitude: 1.0
 - Frequency: 0.0
 - Phase angle: 0.0
 - Mean amplitude: 0.0
 - Termination time: 0.0
- Variation
 - Termination time: 0.0
 - Sampling increment: 0.0
- Activation time: 0.0
- Scaling factor: 1.0
- Analysis: Analysis 2 – Day-night variation
- Name: Initialisation curve (5)
- Buttons: OK, Cancel, Apply, Help

(This will give a curve with a mean factor of 20, a maximum factor of $20+10 = 30$, a minimum factor of $20-10 = 10$; varying with a cosine function starting at max amplitude, getting to minimum amplitude at $1/2 = 0.5$ days, back up to max amplitude at 1 day and repeating every 1 day.)

- Specify a Termination time of **3** days, give it the name **Day-night curve 3 days** and click **Apply**.
- Lastly, untick the Termination time, change the Activation time to **3** days, enter a name of **Day-night curve 3 to 30 days** and click **OK**.

Loadcurve types explained

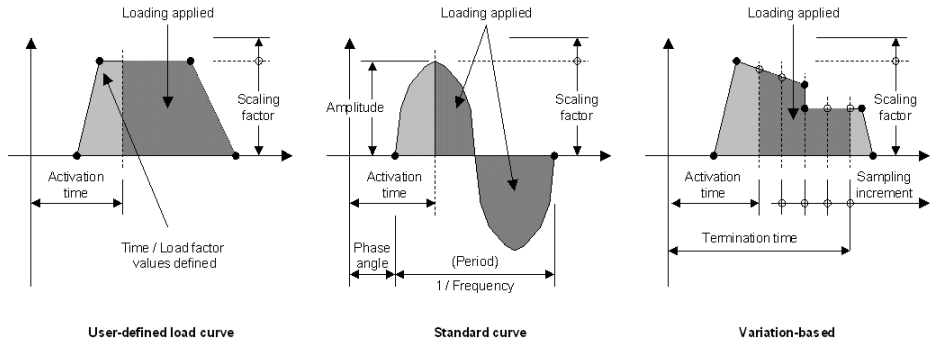

See the LUSAS Modeller help topic for more information.

Defining environmental conditions

- Select **Environmental conditions** and click **Next**.
- Uncheck **Temperature dependent**.
- Enter an Environmental temperature of **1** and a Convection heat transfer coefficient of **8.333**. Enter a name of **Unit Face Air Temperature** and **Apply**.
- Leave the Environmental temperature as **1** and change the Convection heat transfer coefficient to be **7**. Enter a name of **Unit Face Formwork Temperature** and click **Finish**.

Note. When using loadcurves, loads are assigned to the loadcurves rather than to the loadcases. The time controls within the loadcases then determine what loads are actually present, based on the load curves.



Assigning environmental conditions

With the whole model selected:

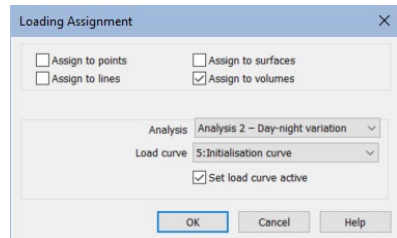
- From the treeview, drag and drop the **Initial Temp** loading onto the volumes selected, for **Analysis 2 – Day-night variation**, assigning it to the load curve named **Initialisation curve**.
- Click in an empty region of the view window to deselect the selection.



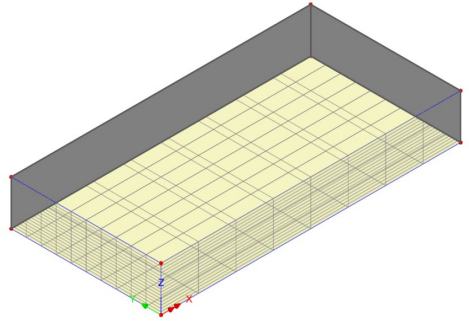

Side faces

- Select the two outer vertical faces of the base slab.
- From the  treeview, drag and drop the **Unit Face Formwork Temperature** onto the selected surfaces for **Analysis 2 – Day-night variation**. For the Environmental temperature select **Day-night curve 3 days** and click **OK**. This will take the defined temperature (1 degree Celsius) and multiply it by the varying load factor (10 to 30) to give a temperature of 10 to 30 degrees Celsius.
- From the  treeview, drag and drop the **Unit Face Air Temperature** onto the selected surfaces for **Analysis 2 – Day-night variation**. For the Environmental temperature select **Day-night curve 3 to 30 days** and click **OK**.



Top face

- Select only the top face of the slab
- From the  treeview, drag and drop the **Unit Face Air Temperature** onto the selection for **Analysis 2 – Day-night variation**. For the Environmental temperature select **Day-night curve 3 days** and click **OK**.
- From the  treeview, drag and drop the **Unit Face Air Temperature** onto the selected surfaces for **Analysis 2 – Day-night variation**. For the Environmental temperature select **Day-night curve 3 to 30 days** and click **OK**.

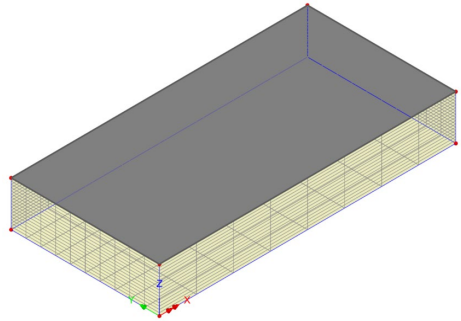

Bottom of slab

- Select only the bottom face of the slab.
- From the  treeview, drag and drop the **Face Ground Temperature** onto the selection. For the Environmental temperature select **Constant curve** and click **OK**.

The ground temperature does not vary significantly between day and night, so the coefficients can be left as Constant (no load curve).

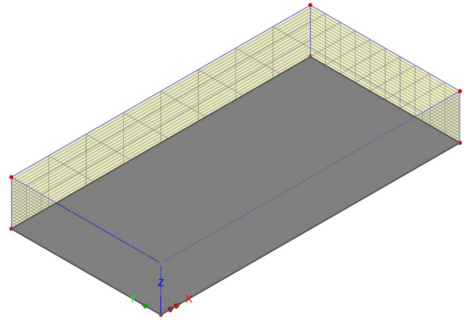

Define nonlinear and transient controls

'Initialisation day-night' loadcase

- In the  Treeview, right-click on the **Initialisation Day-night** loadcase and select **Controls** then **Nonlinear and transient**.
- In the Incrementation section tick **Nonlinear** to turn it on.
- Select **Time Domain**, enter an initial timestep of **1e-3**, a total response time of **1e-3**, a maximum number of time steps of **1**, and click **OK**.

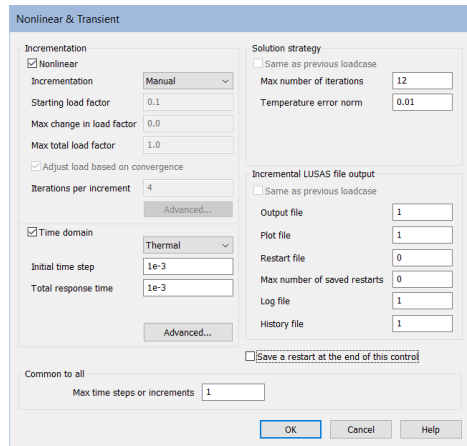

The screenshot shows the 'Nonlinear & Transient' dialog box with the following settings:

- Incrementation**
 - Nonlinear
 - Incrementation: Manual
 - Starting load factor: 0.1
 - Max change in load factor: 0.0
 - Max total load factor: 1.0
 - Adjust load based on convergence
 - Iterations per increment: 4
- Time domain**
 - Time domain
 - Initial time step: 1e-3
 - Total response time: 1e-3
- Solution strategy**
 - Same as previous loadcase
 - Max number of iterations: 12
 - Temperature error norm: 0.01
- Incremental LUSAS file output**
 - Same as previous loadcase
 - Output file: 1
 - Plot file: 1
 - Restart file: 0
 - Max number of saved restarts: 0
 - Log file: 1
 - History file: 1
- Save a restart at the end of this control
- Common to all**
 - Max time steps or increments: 1



Buttons: OK, Cancel, Help

'30 Days day-night' loadcase

- In the  Treeview, right-click on the **30 days Day-night** loadcase and select **Controls** then **Nonlinear and transient**.
- In the Incrementation section tick **Nonlinear** to turn it on.
- Select **Time Domain**, enter an initial timestep of **0.05**, a total response time of **30**

- Click the **Advanced** button and change the Time step increment factor to **1.25** and click **OK**. Then **OK** again to exit the main dialog.

Checking the Attributes and Analyses Treeviews

The Attributes  Treeview and the Analyses  Treeview now contain all the information for an analysis to be carried out.

For a successful analysis your model should contain treeviews similar to those that follow. Right-clicking on attribute and loadcase data allows any defined values to be checked. If your model has potential errors in your Attribute data, or in your Loadcase assignments, a file is provided to enable you to re-create the model from scratch and run the analysis successfully.

Attributes treeview

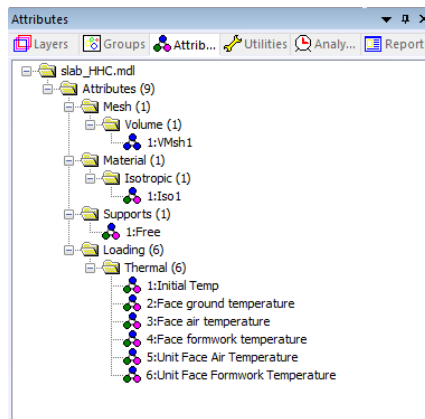

Analyses treeview

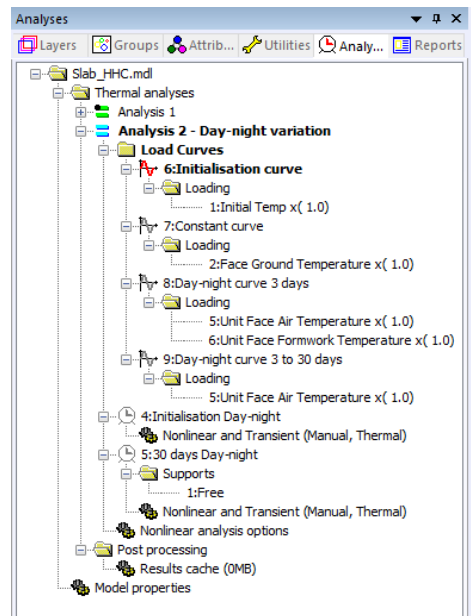

Running the Analysis

With the model loaded:



Open the **Solve Now** dialog.

- Ensure that **Analysis 2** is selected and press **OK** to run the analysis.

If the analysis is successful...

Analysis loadcase results are added to the  Treeview.

Associated files will be created in the LUSASFiles\<model_name> folder.

If the analysis fails...

If the analysis fails, information relating to the nature of the error encountered is written to an output file in addition to the text output window. Any errors listed in the text output window should be corrected in LUSAS Modeller before saving the model and re-running the analysis.

Rebuilding a Model

If it proves impossible for you to correct the errors reported the following file is provided to enable you to re-create the model from scratch and run an analysis successfully:



- slab_HHC_loadcurves.lvb** carries out the modelling the whole example ready for a solve to be undertaken.



Start a new model file. If an existing model is open, Modeller will prompt for unsaved data to be saved before opening the new file.

- Enter the file name as **slab_HHC**
- Select units of **N,m,kg,s,C**
- Ensure the **Thermal** user interface is selected and click the **OK** button

- To recreate the model, open the file **slab_HHC_loadcurves.lvb** that was downloaded and placed in a folder of your choosing.



Run the analysis to generate the results.

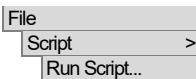
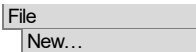

Viewing the Results

Analysis results for each time step are present in the  Treeview.

- In the  Treeview, in the **Analysis 2 – Day-night variation** analysis, for the **30 days Day-night** loadcase, set active the loadcase **Time Step 24 Time = 30.000**

Analysis: Analysis 2 – Day-night variation
 Loadcase: 9:30 days Day-night, 25: Time Step 24 Time = 30.0000
 Results file: slab_HHC-Analysis 2 – Day-night variation.mys
 Response time: 30.0
 Entity: Temperature
 Component (Nodal): Temp (Units: C)

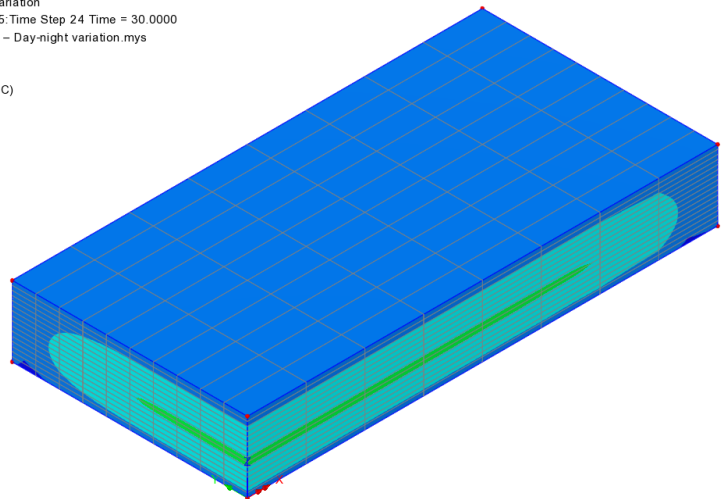
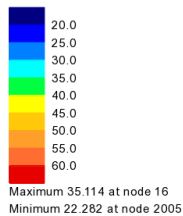

A reduced maximum temperature can be seen. Results can be compared against the previous graphed results in a similar manner to that done previously.

Graphing of temperature at a selected node

A graph is required for the same node as selected previously.

- If not still selected, select the node in the middle of the slab (i.e. at half height, at the corner between the two internal faces, at coordinates (0,0,1.5).
- For the X axis, select **Time history** and press **Next**.
- Select **Named** results for the **Whole Analysis** for **Analysis 2 – day-night variation** and click **Next**.
- Select **Response time** and click **Next**.
- For the Y-axis, select **Nodal** and click **Next**.
- Select entity **Temperature** and Component **Temp**, for the specified single node and click **Next**.
- Title the graph **Temperature over time of node in middle of slab, with day-night variation**. Tick to include the previous graph (**Graph 1**) for comparison. Click **Finish**.

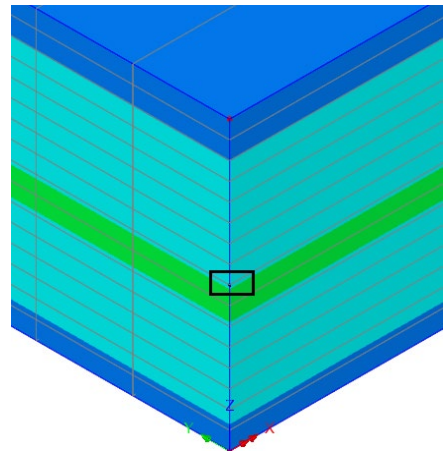

Utilities
 Graph wizard

Heat of hydration modelling of a concrete base slab

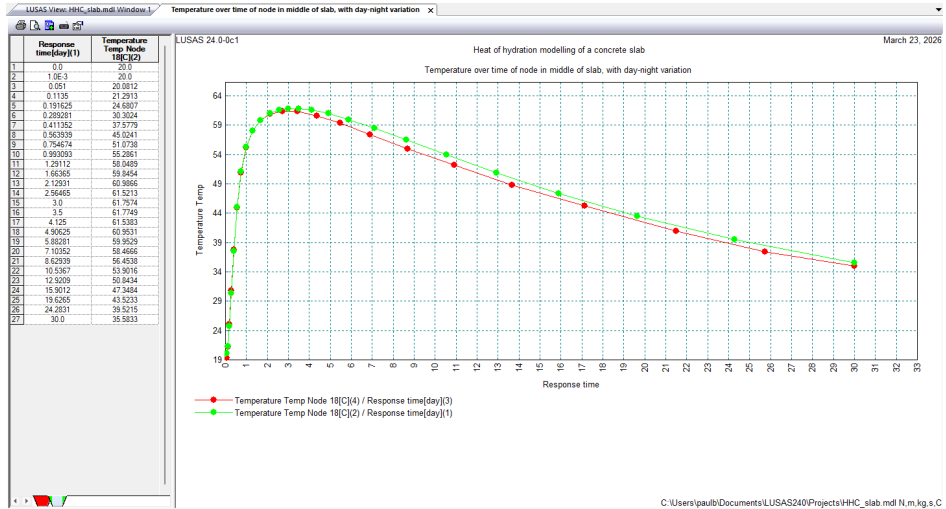

On the graph the red line now shows results for Analysis 2, the green line shows the previously obtained results for Analysis 1.

By selecting the red data tab (which is to the left of the green tab on the graph above), the more realistic modelling of the ambient temperature can be seen to provide slightly lower concrete temperatures from 1 day onwards, including a slightly lower peak temperature of 61.4 degrees after 2.7 days.

This completes the example.