

Contact Analysis of a Lug

For LUSAS version:	24.0
For software product(s):	All (except LT versions) for the first stage of the example Any Plus version for the second stage of the example.
With product option(s):	Nonlinear (for the second part of the example)
Note: Stage 2 of the example exceeds the limits of the LUSAS Teaching and Training Version.	

Description : Linear Analysis

A large lifting lug is supported at its left-hand edge and subjected to a prescribed pressure load around the inside of the hole, modelling a loaded pin.

The lug is 0.546 m thick and made of steel with a Young's modulus of $210E9 \text{ N/m}^2$, a Poisson's ratio of 0.3 and a mass density of 7800kg/m^3 .

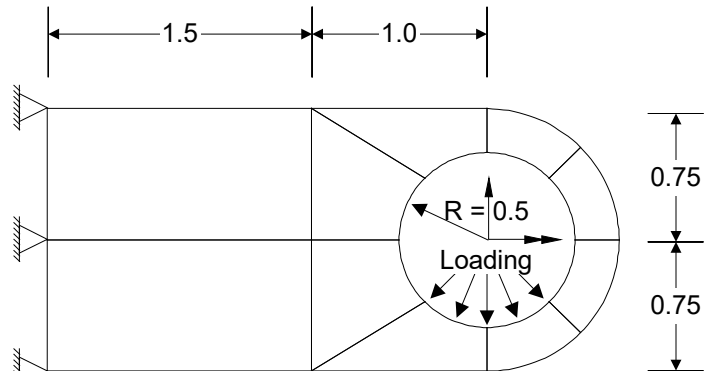

This is a two-stage example. A linear static analysis is carried out initially and the material properties and loading are then modified to investigate the response of the lug using a nonlinear analysis.

Units used are N, m, kg, s, C throughout.

Objectives

The output required from the linear analysis consists of:

- Deformation Plot** A plot of the undeformed and deformed mesh.
- Contour Plot** A Von Mises stress plot.
- Principal Stress Vectors** A plot of principal stress vectors.
- Fatigue Damage** A plot of the fatigue damage when the component is subjected to a prescribed loading sequence.
- Cycles to Failure** A contour plot of the number of cycles to failure for the area around the hole.

Keywords

2D, Inplane, Plane Stress, Default Assignments, Linear, Slideline, Nonlinear, Contact, Fatigue, Damage, Cycles to Failure, Stress Contours, Displacement Results, Animation, Graph Plotting.

Associated Files

Associated files can be downloaded from the user area of the LUSAS website.



- lug_linear_modelling.lvb** carries out the modelling for the linear analysis.
- lug_nonlinear_modelling.lvb** carries out the modelling for the nonlinear contact analysis.

Stage 1. Linear Analysis

An initial linear investigation is performed to verify the model. An assessment of potential damage and a calculation of the cycles to failure are performed.

Stage 2. Nonlinear Analysis

Material properties on the linear model are then modified to investigate the response of the lug using a nonlinear analysis. The pressure loading is removed and an additional pin of 0.9m diameter is defined. Slidelines are defined on the surfaces that will come into contact and the pin is then subjected to a prescribed concentrated loading and moved into contact with the lug.

Stage 1 : Modelling : Linear Analysis

Running LUSAS Modeller

For details of how to run LUSAS Modeller, see the heading *Running LUSAS Modeller* in the *Introduction to LUSAS Worked Examples* document.



Note. This example is written assuming a new LUSAS Modeller session has been started. If continuing from an existing Modeller session select the menu command **File>New** to start a new model file. Modeller will prompt for any unsaved data and display the New Model dialog.

Creating a new model

- Enter the file name as **lug_linear**
- Use the default user-defined working folder.
- Select an Analysis Category of **2D Inplane**
- Select a Startup template of **2D Plane Stress**.
- Set the model units to **N,m,kg,s,C**
- Ensure the timescale units are **Seconds**
- Enter the title as **Fixing Lug (Linear analysis)**
- Click the **OK** button.

The Attributes  treeview will be populated with potentially useful basic line mesh, geometric and support entries appropriate to the settings made.



Note. Use the Undo button to correct any mistakes made since the last save was done.

Default Attribute Assignments

The material properties of the lug, its element type and thickness are uniform over the model. Default attribute assignments can therefore be used, meaning that any material, mesh or geometry attribute defined will be automatically assigned to any features that are subsequently generated.

Default Element Selection

The lug is a relatively thin structure, and all deformations take place in the plane of the structure therefore plane stress continuum elements will be used.

Contact Analysis of a Lug

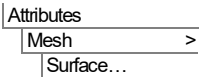

- Select **Plane stress, Quadrilateral, Quadratic** elements. Ensure the **Regular mesh** option is selected with **Automatic** mesh divisions so that LUSAS uses the default number of mesh divisions on each line. Name the attribute **Plane stress QPM8** and Click **OK**



Modeller will add the attribute to the  Treeview.

- To make this attribute the default for all subsequent geometry, click the right-hand mouse button on the mesh attribute **Plane stress QPM8** in the  Treeview and select the **Set Default** option.

The selected attribute will be highlighted to signify that it has been set as the default for all subsequent features.

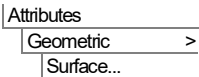
Default Geometric Properties



- Whilst model units of metres are in use, if necessary, units can be input and converted into model units. To do this, click in the thickness value area and press the  button to open the **Unit Converter and Variation Utility**.
- Change the units to **mm** in the drop-down menu and enter a value of **546**. Press **OK** to convert the value that was entered into model units of metres.
- No eccentricity needs to be entered.
- Enter the attribute name as **Lug Thickness 0.546** and click **OK**.
- To make this attribute the default for all subsequent geometry click the right-hand mouse button on the geometry attribute name in the  Treeview and select the **Set Default** option.

Default Material Properties

The Attributes  treeview contains a suitable material for this example.

- To make the mild steel material attribute the default for all subsequent geometry click the right-hand mouse button on the **Steel (Mild Steel | Steel – Structural)** material attribute name in the  Treeview and select the **Set Default** option.

Defining the Geometry

Use will be made of the symmetry of the lug by defining the top half and then mirroring it to form the whole structure. In this problem the centre of the hole will be taken as the origin (0,0,0).

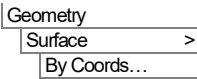

Define a surface by specifying the coordinates of its vertices using the following pairs of X,Y values (-2.5, 0), (-1, 0), (-1, 0.75) and (-2.5, 0.75). The view axis origin at 0,0 will not be visible yet.

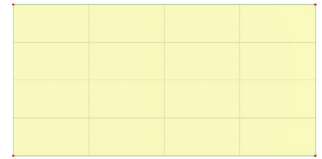

Note. Whenever a surface is created the corresponding surface mesh will be displayed. For clarity the diagrams included in this example will not generally show the mesh. At any time the display of the mesh can be turned on or off by right-clicking on the Mesh entry in the  Treeview and selecting the Display option.

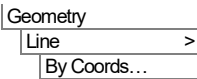

Define a line by specifying the coordinates of either end as X,Y values of (0.5, 0) and (0.75, 0).

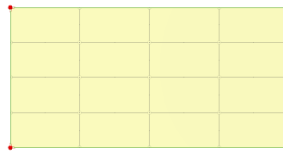

Note. LUSAS automatically generates any necessary lower order features (points in this case) when higher order features are defined.

New surfaces will be created by sweeping the line just drawn through a positive (anti-clockwise) angle about the centre of the hole.

- Select the newly created line.

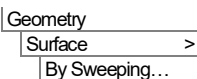

Rotate the line through an angle of **45** degrees about the Z-axis and an origin of (0,0,0) to sweep through a **Minor arc** to create a **Surface**.

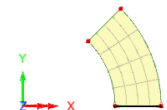
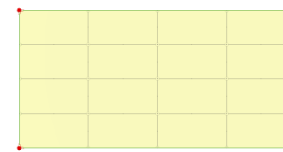

- Enter the attribute name as **Rotate 45 Degrees** so that it can be re-used.
- Click on the **Save** button to save the attribute information and click the **OK** button to finish.

LUSAS will create a new surface from the selected Line. This will now be copied to create the adjoining surface.

- Select the **surface** just created.

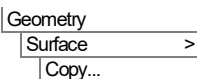

Contact Analysis of a Lug



On the Copy dialog, select the **Rotate 45 degrees** attribute from the drop-down list to use the values defined.

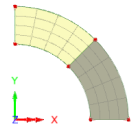
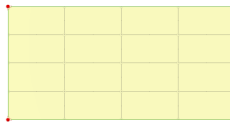

- Click the **OK** button to create the new surface.

The arc forming the surface of the hole is to be extended.

- First, select the point, as shown in the next image to create the first arc.



Select the **Rotate 45 degrees** attribute from the drop-down list to use the values defined.

- Click the **OK** button to create the new arc.
- Secondly, select the point at the end of the new arc and repeat the previous process to draw a second arc.

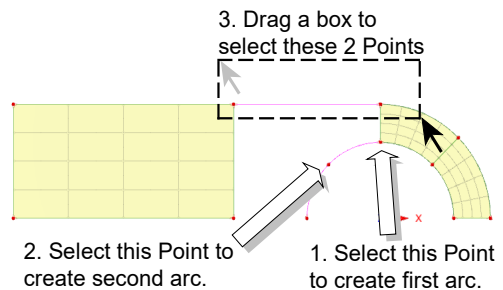

- Thirdly, drag a box around the two unconnected points at the top of the model.



Select the New Line button to create the connecting line.

Two new surfaces will now be formed by joining pairs of existing opposite lines.

- Select the first two lines required in the order shown. Use the **Shift** key to add to the initial selection.
- Use the joining function, to create a surface between the specified lines.

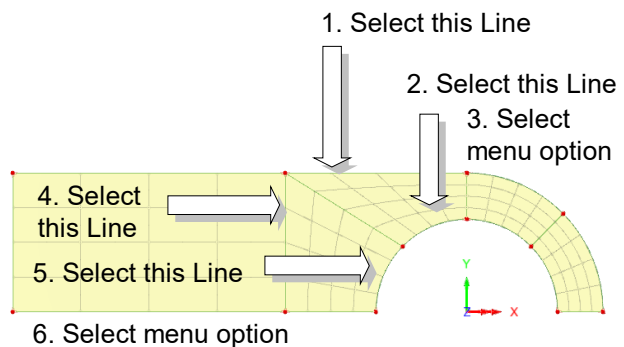

- Repeat for the remaining two lines as shown.

The top half of the lug is now complete.

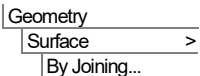
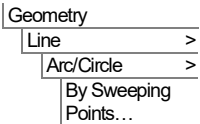

Mirroring the Lug

The bottom half of the lug is to be formed by mirroring the top half.

- Drag a box around the whole of the top half of the lug or use the **Ctrl + A** keys together to select the whole model.

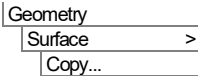

Choose the **Mirror (screen)** option and select the **Bottom** radio button to mirror about the bottom (line) of the selection. Click the **OK** button to finish. The surfaces will be copied and mirrored.

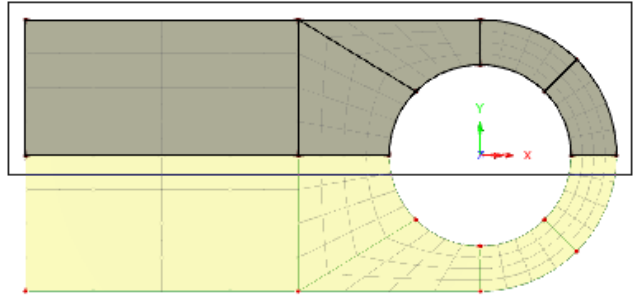

Note. As a consequence of mirroring the surfaces, the orientation of the surfaces in the top half of the model will be opposite to the orientation of the surfaces in the bottom half of the model. The orientation of the surfaces must therefore be checked.

Aligning Surface axes

To ensure the loading directions are consistent the element axes should be aligned. The element axes follow the direction of the surface they are generated from. These may vary depending upon how your surfaces were created.

- In the  Treeview right click on **Geometry** and select **Properties**
- On the properties dialog select the **Surface axes** option and click **OK** to display the surface axes.

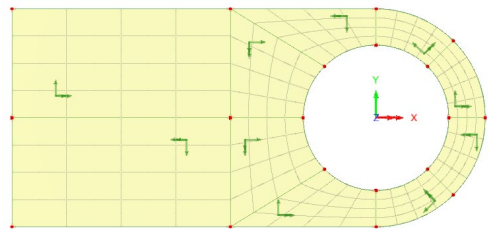

The axes of all surfaces can be aligned to axes of the first surface in the selection using the cycle relative facility.

- Select the top left-hand surface.
- Hold the **Shift** key and box-select the whole model to add the remaining surfaces to the selection.

Contact Analysis of a Lug

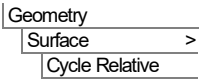

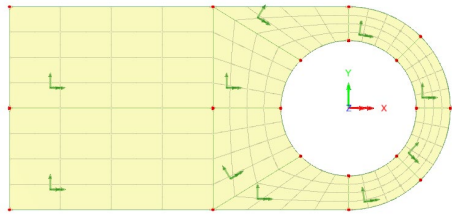

The axes of all surfaces will be aligned to the axes of the first element selected.

- In the  Treeview right click on **Geometry** and select **Properties**
- On the properties dialog deselect the **Surface axes** option and click **OK** to remove the surface axes from the display.



Supports

A range of supports were initially added to the Attributes  Treeview as a result of selecting the Startup template for this example.

- Drag a box around the 2 vertical lines on the left of the model.
- Drag the support attribute **Fixed in XY** from the  Treeview and drop onto the selected lines in the view window.
- Ensure the options to **Assign to lines** for **All analysis loadcases** are selected and click **OK** to finish assigning the support attribute.

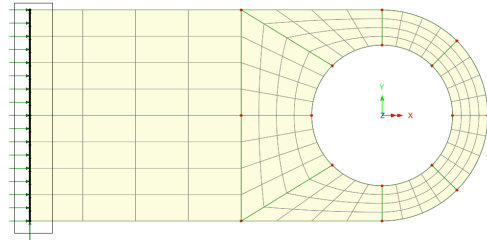

The supports will be visualised as arrows at the supported nodes in the directions of the restraints.

Loading



In this linear analysis, pin loading is to be approximated by defining a face load of a value equivalent to the full load that will be applied during the nonlinear analysis. The face load will be assigned to the two lines defining the lower side of the hole.

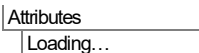

Note. Face loads are applied in local element directions, hence a load in the Y direction will act in a radial direction.



- Select the **Distributed loads** option, then **Face** and click **Next**
- Click in the Component > y Direction cell and press the  button to open the **Unit Converter and Variation Utility**.
- Input a load value of **10 N/mm²** and press **OK** to convert the face load to model units and populate the grid.

- Enter the attribute name as **Face Load** and click **Finish** to add the attribute to the  Treeview.
- Select the 2 arcs forming the lower side of the hole, then drag and drop the **Face Load** attribute from the  Treeview onto the selected features.
- Ensure that the **Assign to Lines** and **Single loadcase** options are selected. Then press **OK** to assign the load to **Analysis 1** and **Loadcase 1**.

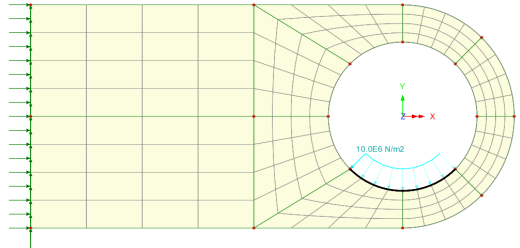

Saving the model

File
Save



Save the model file.

Running the Analysis : Linear Analysis



Open the **Solve Now** dialog and press **OK** to run the analysis.

A LUSAS Datafile will be created from the model information. The LUSAS Solver uses this datafile to perform the analysis.

If the analysis is successful...

Analysis loadcase results are added to the  Treeview.

In addition, these files will be created in the LUSASFiles\<>model_name> folder:



- lug_linear.out** this output file contains details of model data, assigned attributes and selected statistics of the analysis.
- lug_linear.mys** this is the LUSAS results file which is loaded automatically into the  Treeview to allow results processing to take place.

If the analysis fails...

If the analysis fails, information relating to the nature of the error encountered can be written to an output file in addition to the text output window. Any errors listed in the text output window should be corrected in LUSAS Modeller before saving the model and re-running the analysis.

Rebuilding a Model

If it proves impossible for you to correct the errors reported a file is provided to enable you to re-create the model from scratch and run an analysis successfully. You may download this file from the user area of the LUSAS website.



- **lug_linear_modelling.lvb** carries out the modelling of the example.



 Start a new model file. If an existing model is open Modeller will prompt for unsaved data to be saved before opening the new file.

- Enter the file name as **lug_linear**
- Use the default **User-defined** working folder.
- Ensure an Analysis type of **2D Inplane** is set.
- Click the **OK** button.



Note. There is no need to enter any other new model details when a script is run to build a model, since the contents of the script will overwrite any other settings made.

To recreate the model, select the file **lug_linear.lvb** that was downloaded and placed in a folder of your choosing.

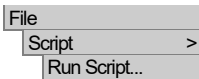

 Rerun the analysis to generate the results.

Viewing the Results : Linear Analysis

Analysis loadcase results are present in the  Treeview and the loadcase results for the last solved loadcase (Loadcase 1) are set to be active by default.

For clarity, selected layers will be removed from the display to leave only the undeformed mesh displayed.

- If present, turn off the display of the **Mesh, Geometry** and **Attributes** layers from the  Treeview.

Using Page Layout Mode

The model was created using a Working Mode view which allows a model of any size to be created. Results could be viewed using this mode of operation, but, in order to allow additional information to be added without obscuring the model, Page Layout Mode can be used instead.

View
Page Layout Mode

The View window will resize to show the mesh layer on an A4 size piece of paper.

File
Page Setup...

- Ensure that the **Landscape** option is selected, ensure that page margins of **60,10,10,10** are set for left, right, top and bottom margins respectively and click **OK**

This page layout view can also be saved for subsequent re-use with other models.

Window
Save View...

- Enter the view name as **Landscape Page Layout** and click **OK**

Deformed Mesh Plot

The deformed mesh layer should be already being displayed.

- If not already visible, turn on the Deformed mesh layer by clicking the right-hand mouse button in a blank part of the View window and selecting the **Deformed mesh** option. This adds the deformed mesh layer to the  Treeview.
- Click on the **OK** button to accept the default properties and display the deformed mesh.

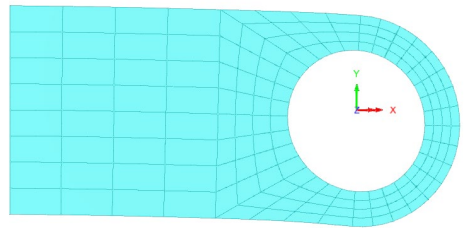



Von Mises Stress Contours

- With no features selected click the right-hand mouse button in a blank part of the view window and select the **Contours** option to add the contours layer to the  Treeview.

The contour layer properties will be displayed.

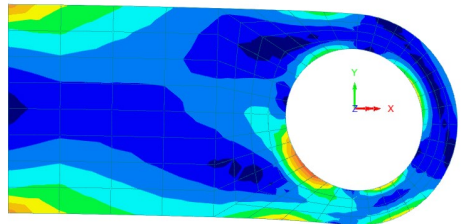
- Select **Stress – Plane Stress** contour results of equivalent stresses **SE**
- Click the **OK** button to display the contours and annotated contour summary.



Note. The order of the layer names in the  Treeview generally determines the order in which any colour filled layers will be displayed in the view window. Note that the element mesh will always be drawn on top of a contour layer regardless of the location of a mesh layer in the  Treeview.

Marking Peak Values



- With no features selected click the right-hand mouse button in a blank part of the View window and select the **Values** option to add the values layer to the  Treeview.

The values properties will be displayed.

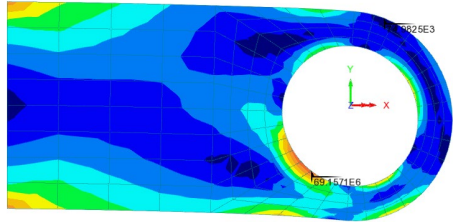
- Select **Stress - Plane Stress** contour results of Equivalent stresses **SE**
- Select the **Values Display** tab and with **Maxima** and **Minima** checkboxes selected, display the top **1%** of results on the Deformed shape.
- Click the **OK** button to redisplay the contours with the peak value marked.



Principal Stress Vectors

- Turn off the **Contours** and **Values** layers in the  Treeview.
- With no features selected, click the right-hand mouse button in a blank part of the View window and select the **Vectors** option to add the vectors layer to the  Treeview.

The vector layer properties will be displayed.

- Select **Stress - Plane Stress** vector results of **Principal** stress.
- Click the **OK** button to display vectors with tension vectors displayed in red and compression vectors displayed in blue. Note that the length of a vector can be controlled by a scale setting on the vector layer properties dialog.
- Turn off the **Vectors** layer in the  Treeview.

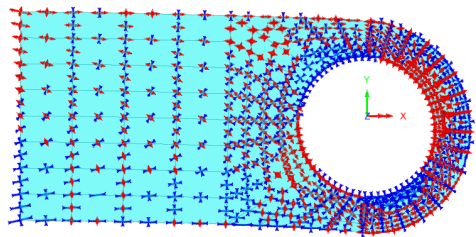

Defining a Fatigue Spectrum

Analyses
Fatigue...

- For Entity select **Stress – Plane Stress**
- For Component select **Sabs**
- In the Available panel select **Loadcase 1** and click the  'Add to' button to include Loadcase 1 in the fatigue load spectra calculation.
- In the Included panel of the dialog enter the number of **Cycles** for loadcase 1 as **10000**

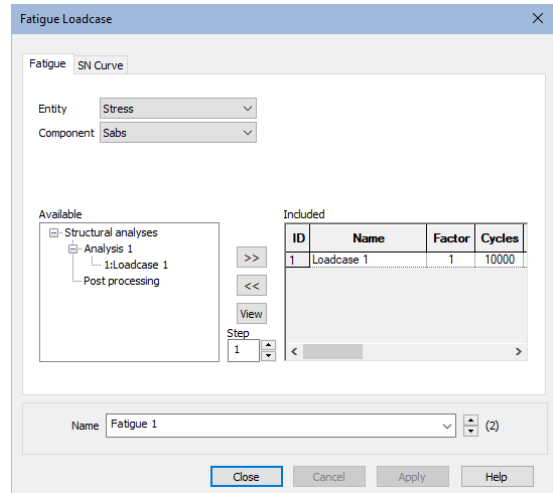



- Select the **S N Curve** tab and enter the values as shown in the adjacent table.
- Leave the name as **Fatigue 1** and click the **OK** button to finish.
- In the  Treeview right-click on the loadcase **Fatigue 1** and select the **Set Active** option.

Log Stress/Strain	Log Cycle
4.7323	15
9.7323	0

Contouring Damage

Contouring damage must be done on an undeformed mesh view. The deformed mesh layer will be turned off.

- Turn on the **Mesh** layer in the  Treeview.
- Turn on the **Contours** layer in the  Treeview. (The previous contour settings will need to be changed).
- In the  Treeview double-click on the **Contours** layer (click **OK** to accept that the previously selected component is not now valid) and select entity **Stress – Plane Stress** and results component **Damage**.

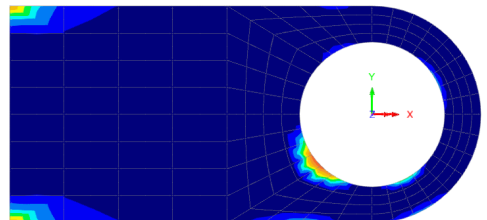



Contact Analysis of a Lug

- Select **Yes** to change the Values layer settings to match those of the Contours layer.
- Select the **Contour Display** tab and ensure the **Contour key** option is selected.
- Click the **OK** button to display contours of damage and a contour summary.

Contouring Cycles to Failure

Modeller can calculate the number of repeats of a given loading sequence to failure. An extra fatigue spectrum will be created containing only a single loading cycle.

- For entity select **Stress – Plane Stress** and for Component select **Sabs**
- In the ‘Available’ panel select **Loadcase 1** and click the  ‘Add to’ button to include Loadcase 1 in the fatigue load spectra calculation.
- Leave the name as **Fatigue 2**.
- Select the **SN Curve** tab and enter the values as shown in the table.
- Click the **OK** button to finish.
- In the  Treeview right-click on the loadcase **Fatigue 2** and select the **Set Active** option.
- In the  Treeview double-click on the **Contours** layer.

Log Stress/Strain	Log Cycle
4.7323	15
9.7323	0

The contour plot properties will be displayed.

- Select entity **Stress – Plane Stress** contour results of component **LogLife** and display **Averaged nodal** results
- Click the **OK** button to display contours of log life. Confirm that the Values layer should be updated to suit.
- Turn on the display of the **Values** layer.

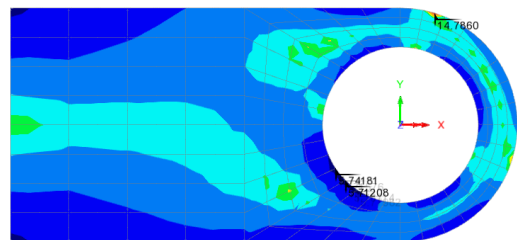

A maximum value of 14.78 should be obtained for the LogLife.



Note. As an alternative to having to enter SN Curve data again for this second loadcase, double-clicking on loadcase Fatigue 1 and changing the loadcase name to Fatigue 2 and setting the number of Cycles to 1 would achieve the same result.

Changing the levels

The contours of LogLife will be easier to understand if the contour levels are adjusted so that they are plotted in unit (1.0) increments, representing 10 to the power of 0 cycles to failure.

- In the  Treeview, double-click on the **Contours** layer name and select the **Appearance** tab and for the **Classic** contour range press the **Set** button.
- Set a contour **Interval** of **1**. Ensure the **Value to pass through** is set to **0** and click **OK**.
- Click the **OK** button again to update the display of contours of LogLife and the contour summary using the increments specified.

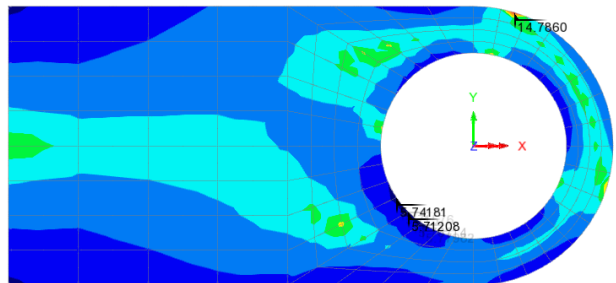
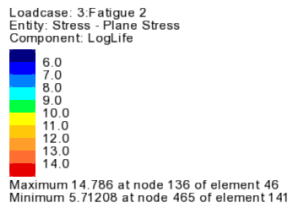

This completes the linear analysis section of the example.



Note. Saving the model file at this point will also save the fatigue loadcases.

Stage 2 : Nonlinear Contact

For software product(s):	Any Plus version.
With product option(s):	Nonlinear.
Note: Stage 2 of the example exceeds the limits of the LUSAS Teaching and Training Version.	

Description : Nonlinear Analysis

This part of the example extends the previously defined lug model used for the linear analysis.

The pressure loading is removed and an additional pin of 0.9m diameter is defined. Slidelines are defined on the surfaces that will come into contact and the pin is then subjected to a prescribed concentrated loading and moved into contact with the lug.

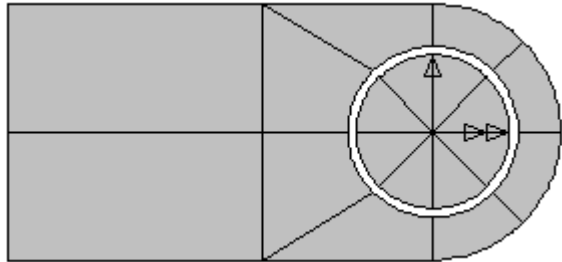

A schematic of the lug and pin geometry is shown.

The units of the analysis are N, m, kg, s, C throughout.

Objectives

The output required from the analysis is as follows:

- Equivalent Stress Contours** A plot of the stress in the lug only.
- Graph of Displacement against Applied Load** A graph of the resultant displacement at a selected node.

Stage 2 : Modelling : Nonlinear Analysis

If the linear analysis was successful:

 If the previous linear analysis was performed successfully open the model file **lug_linear.mdl** saved after completing the first part of this example and select **No** to not load a results file of the same name on top of this model.

- Enter the model file name as **lug_nonlinear** and click the **Save** button.

File
Open...

File
Save As...

Creating a suitable model from a supplied file

You may download this file from the user area of the LUSAS website.



- ❑ **lug_linear_modelling.lvb** This carries out the modelling of the example.

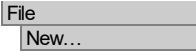

Start a new model file. If an existing model is open Modeller will prompt for unsaved data to be saved before opening the new file.

- Enter the file name as **lug_linear_modelling**
- Use the default **User-defined** working folder.
- Ensure an Analysis category of **2D Inplane** is set.
- Click the **OK** button



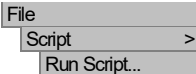

Note. There is no need to enter any other new model details when a script is run to build a model, since the contents of the script will overwrite any other settings made.



- To recreate the model, select the file **lug_linear_modelling.lvb** that was downloaded and placed in a folder of your choosing.

Once created:

Changing the model description

- Change the model title to **Fixing Lug - Nonlinear Contact Analysis** and click **OK**
- If present, turn off the **Contours**, **Mesh** and **Annotation** layers in the  Treeview.
- In the  Treeview, ensure the **Geometry** layer is turned on, and double-clicking on that entry, ensure that the display of surface axes is turned off.
- In the  Treeview expand **Analysis 1** and ensure **Loadcase 1** is set active.



Defining the Lug

For clarity the diagrams accompanying this example will not generally show the mesh.

- Drag a box around the whole of the model (or use the **Ctrl + A** keys) to select the whole model.



Select the group button to create a group.

Contact Analysis of a Lug

- Enter the name **Lug** and click **OK** to finish creating the group and add it to the  Treeview.

Defining the Pin

- Select the line on the lug shown. Take care to not include any other features.



Select the **Scale** option and enter a scale factor of **0.9**

- Click the **OK** button to create the inner arc.

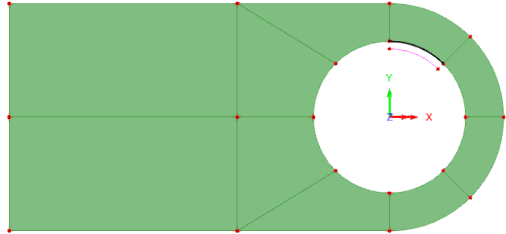

Enter coordinates of **(0, 0)** to define a point at the origin and click **OK**

- Select the line just created and holding the **Shift** key down, also select the point at the origin.

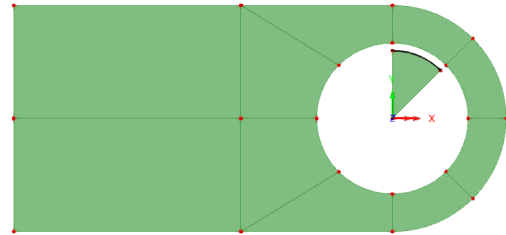

A new surface will be created. The other surfaces of the pin will be created shortly.

Modifying the Line mesh divisions

The total number of mesh divisions on the Pin is to be reduced and then modified.

- Turn on the **Mesh** layer.
- Select the arc on the initial segment of the pin.
- Drag and drop the line mesh attribute **Null, div = 2** from the  Treeview onto the selected line.
- With the element description set as **None**, enter the number of divisions as **2**
- Click the **Spacing** button, select a **Uniform transition** ratio of first to last element of **0.333** and click **OK** to return to the mesh dialog.

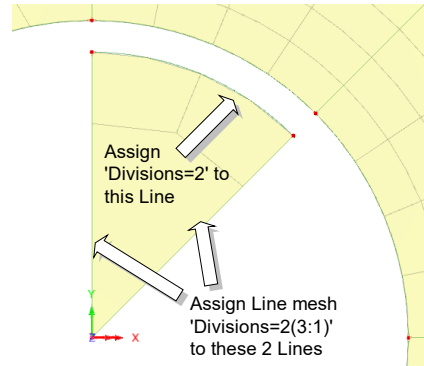

- Enter the attribute name as **Null, div = 2(3:1)** and click **OK**

LUSAS will add the attribute name to the  Treeview.

- Select the 2 straight lines on the surface of the Pin as currently defined.
- Drag and drop the line mesh attribute **Null, div = 2(3:1)** from the  Treeview onto the selected features. The mesh arrangement should now be as shown in the previous image.



Note. The last/first element spacing ratio depends upon the direction of the line on which it is assigned. If the mesh is finer at the centre of the Pin than at the edge, then reverse the line(s) by first selecting with the mouse and using the menu command **Geometry > Line > Reverse**

The remainder of the Pin is to be generated by copying the initial segment of the Pin.

- Select the **surface** defining one-eighth of the Pin.



From the drop-down list, select the attribute **Rotate by 45 degrees**

- Set the number of copies to 7
- Click the **OK** button to create the new surfaces forming the entire pin.

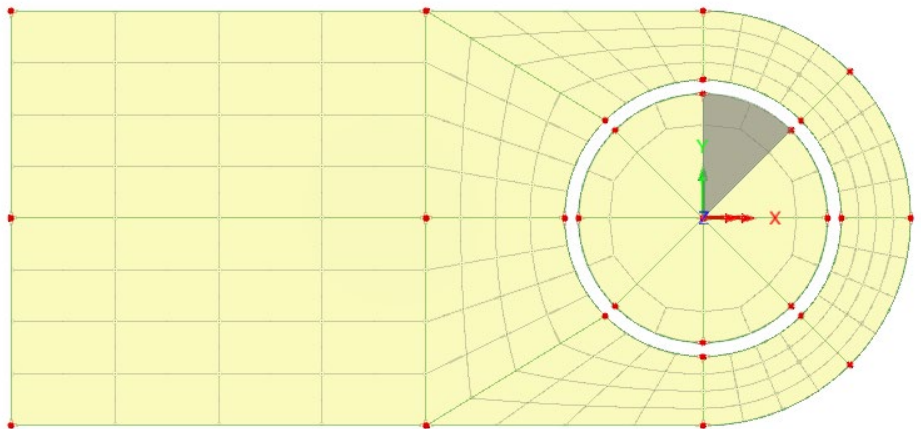
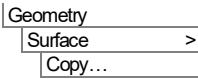

Using Groups

To allow easy selection of the features defining the pin, the group named **Lug** is to be hidden.

- In the  Treeview right-click on the group name **Lug** and select the **Invisible** option to leave just the surfaces representing the pin displayed.
- Drag a box around the features defining the pin (or use the **Ctrl + A** keys).

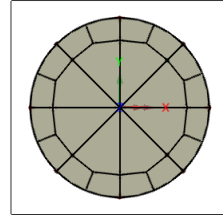

Select the group button to create a group.

- Enter the name **Pin** and click **OK** to finish creating the group and add it to the  Treeview.

Geometric properties of the pin

- Enter the thickness as **10** and the attribute name as **Pin Thickness 10**. Click **OK**
- Box-select the Pin in the View window and from the  Treeview drag and drop **Pin Thickness 10** onto the selected features.

Redisplay the lug

- In the  Treeview right-click on the group name **Lug** and select the **Visible** option to re-display the lug.



Modifying the mesh

If quadratic elements are used for slideline models, constraints are automatically introduced to make the contact face perform as a linear element. It is therefore recommended that linear, rather than quadratic, elements are used instead.

So the Plane stress elements (having linear interpolation order) as added to the  Treeview by the 2D Plane Strain startup template will be assigned to the whole model in place of the existing elements.

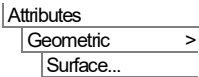
- If not already displayed, turn on the **Mesh** layer.
- Turn on the display of the **Attributes** layer
- Turn off the display of any loading.



- Press the **Ctrl + A** keys to select all features.
- Drag and drop the **Plane Stress** attribute from the  Treeview onto the selection and click **OK** to overwrite the previous mesh used.
- To make this attribute the default for all subsequent geometry, click the right-hand mouse button on the mesh attribute **Plane stress** in the  Treeview and select the **Set Default** option.

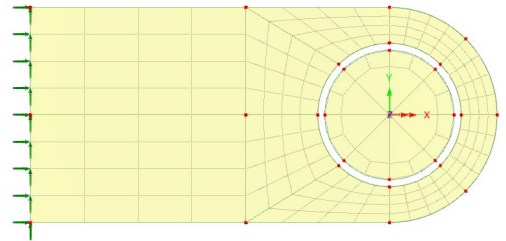



Defining contacting surfaces using slidelines

Slidelines define the contacting surfaces of the model. They are used in pairs (a primary and a secondary) and define opposing contacting surfaces. They are assigned to lines for 2D analyses and to surfaces for 3D analyses. In this analysis, the primary and secondary slides are assigned to selected internal lines of the Lug and selected external lines of the Pin.

Attributes

Slideline...

- Ensure that the **Close contact** parameter is set to **0.1** and leave the remaining values as their default settings.
- Enter the attribute name as **Lug_Pin** and click **OK**
- Select the 4 internal lower arcs of the Lug.
- Drag and drop the slideline attribute **Lug_Pin** from the  Treeview onto the selected features, setting this slideline to be the **Primary**. Leave the orientation as **Default** and click **OK**
- To visualise the slidelines assigned to the model click the right-hand mouse button on the slideline attribute name **Lug_Pin** in the  Treeview and select **Visualise Primary Assignments**

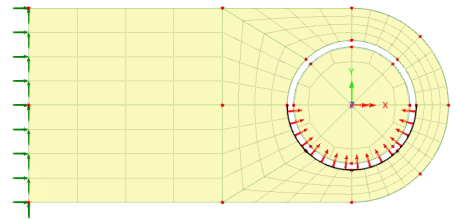

Contact Analysis of a Lug

Now select the 4 lower arcs of the Pin.

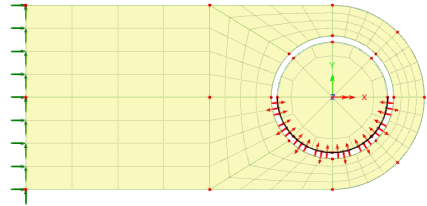

- Drag and drop the slideline attribute **Lug_Pin** from the  Treeview onto the selected features, setting this slideline to be the **Secondary** and click **OK**



- To visualise the slidelines assigned to the model click the right-hand mouse button on the slideline attribute name **Lug_Pin** in the  Treeview and select **Visualise Secondary Assignments**
- After visualising, de-select the visualisation of both sets of slidelines.

Supports and Loads

The loading from the first part of this example is to be removed and will be replaced by a concentrated load. The supports will remain unaltered.

- In the  Treeview click the right-hand mouse button on the loading attribute **Face load**. Select the **Deassign > From all** option.
- Ensure that **Point loads** and **Concentrated** options are selected and click **Next**
- Input a load in the **Y** direction of **-2e8**.
- Enter the load attribute name as **Concentrated Load** and click the **Finish** button.
- Select the **point** at the centre of the Pin.
- Drag and drop the loading attribute **Concentrated Load** from the  Treeview onto the selected point, ensuring that it is applied to **Analysis 1** and **Loadcase 1**

Preventing features from merging together

Now that the modelling is complete the pin can be moved into contact with the lug. This could be done by entering a known dimension, or as shown in this example, by selecting the two points that are to be brought into contact. To prevent the features in the pin merging with those on the lug when the pin is moved into contact the points in the pin are set as unmergable.

- Select all the features in the pin by right-clicking **Pin** in the  Treeview and picking the **Select Members** option.

This ensures the points in the pin are not merged with those in the lug.

Attributes
Loading...

Geometry
Point >
Make Unmergable

Moving the Pin to touch the Lug

- Select the lowest point on the Pin. Hover over the point and make a note of the point number shown.
- Holding the **Shift** key down, select the point immediately beneath it on the hole of the Lug. Hover over the point and make a note of the point number shown.
- Click the right-hand mouse button and select the **Selection Memory>Set** option.
- In the  Treeview right-click on the group name **Pin** and select the **Select members** option to highlight all features representing the pin. Click **OK** to deselect the previously selected points.

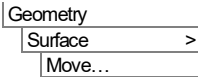
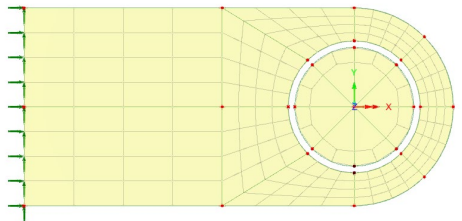

Select the **Translation – from Point 39 to point 23** transformation (or the one that relates to your selected points) from the drop-down menu and click the **Use** button to use the distance between the points stored in memory as the move distance. Click the **OK** button to finish.

The features of the pin will have been moved to rest against the lug at the starting point of the analysis.

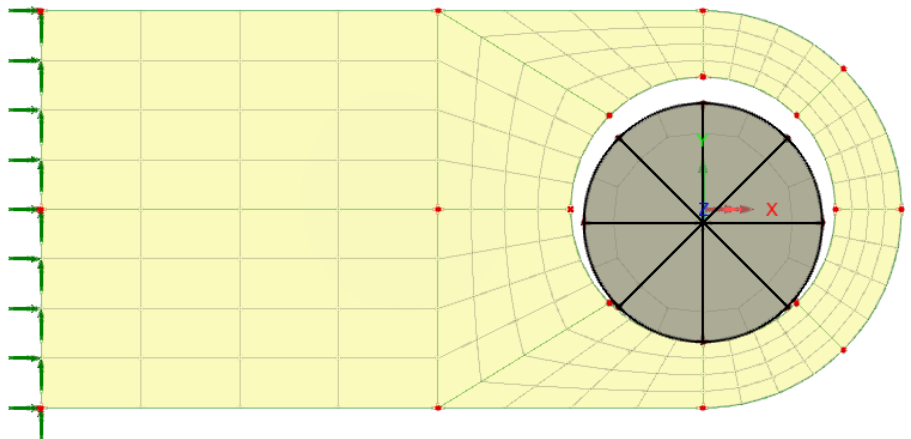

Nonlinear Analysis Control

Nonlinear analysis control properties are defined as properties of a load case.

Contact Analysis of a Lug

- In the  Treeview right-click on **Loadcase 1** and select the **Nonlinear and Transient** option from the **Controls** menu.

The Nonlinear & Transient dialog will appear:

- Select **Nonlinear** incrementation with **Automatic** control.
- Ensure the **Starting load factor** is set to **0.1**
- Enter the **Max change in load factor** as **0.5**
- Enter the **Max total load factor** as **2**
- Ensure that **Adjust load based on convergence** is selected and the number of **Iterations per increment** is set to **4**
- Leave the **Max time steps or increments** set to **0**
- Click the **OK** button to finish.

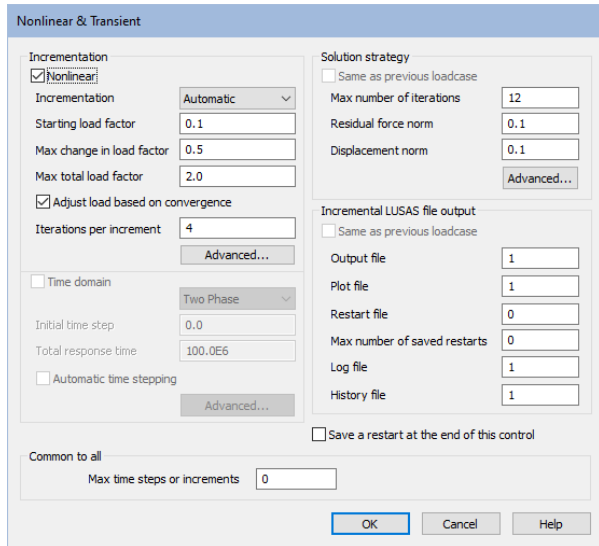

Note. A nonlinear contact analysis performs best when a small amount of load (0.1 of the load in this example is applied to the model initially (although sometimes even smaller amounts of 0.001 may be required in some situations). Thereafter, once the results for a load increment have been obtained the load factor for the next increment is automatically adjusted by LUSAS based upon the number of iterations taken for the previous load increment to converge. After a number of such iterations the loading will be progressively applied to the model until the total load factor is reached.

Saving the model

The model is now complete, and the model data is to be saved before an analysis is run using the LUSAS Solver.



This saves the model.

File
Save

Running the Analysis : Nonlinear Analysis



Open the **Solve Now** dialog. Press **OK** to run the analysis.

- If the nonlinear model includes the Fatigue loading from the linear model, a prompt will appear asking to rename the loadcases. Press **OK**.

In addition, these files will be created in the LUSASFiles\<<model_name> folder:

- lug_nonlinear.out** this contains the statistics of the analysis, for example how much disk space was used, how much CPU time was used, and any errors or warning messages from LUSAS, and so on. Always check the LUSAS output file for error messages.
- lug_nonlinear.mys** this is the LUSAS results database which will be used for results processing.

If the analysis is successful...

Analysis loadcase results are added to the Treeview.

If the analysis fails...

In the event of the analysis failing due to errors in the model that you cannot correct, a file is provided to re-create all modelling features and attributes to allow the analysis to be run successfully.



- lug_nonlinear_modelling.lvb** carries out the modelling of the example.

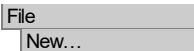

Start a new model file. If an existing model is open Modeller will prompt for unsaved data to be saved before opening the new file.

- Enter the file name as **lug_nonlinear**
- Use the default **User-defined** working folder.
- Ensure an Analysis type of **2D Inplane** is set.
- Click the **OK** button.



Note. There is no need to enter any other new model details when a script is run to build a model, since the contents of the script will overwrite any other settings made.

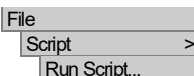

To recreate the model, select the file **lug_nonlinear_modelling.lvb** that was downloaded and placed in a folder of your choosing.



Rerun the analysis to generate the results.

Viewing the Results : Nonlinear Analysis

Analysis loadcase results are present in the  Treeview and the load case results for the last solved loadcase (Increment 10 Load Factor = 2.0) are set to be active by default.

Making the Pin invisible



Note. When a results file is loaded on top of a corresponding model file groups of features can be made visible or invisible. This is of particular use when results are to be displayed only on selected parts of the model. In this example, results are only to be viewed on the Lug.

- In the  Treeview right-click on the group name **Lug** and select the **Set as Only Visible** option.

Deformed Mesh Plot

With **Increment 10 Load Factor = 2.0** in the  Treeview **Set Active**

- Turn off the **Geometry**, **Mesh** and **Attributes** layers in the  Treeview.

The deformed mesh layer should already be displayed.

Equivalent Stress Contour Plots

- Add (if necessary) or turn-on the **Contours** layer in the  Treeview. (if necessary, click **OK** to accept that the previously selected component is not now valid)

The contour properties will be displayed.

- Select **Stress – Plane Stress** contour results of Equivalent stresses **SE**
- Select the **Appearance** tab and for the **Classic** contour range press the **Set** button.
- Ensure the **Number of boundaries** is set to **9**. (Leave the value to pass through set to 0). Click **OK**.

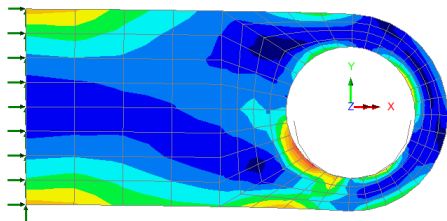

- Click the **OK** button again to display contours and a contour summary for the final load increment.

The contour plot for the final load increment will be displayed, showing a maximum stress in the order of $7E9$.

Creating Animations

As an alternative to viewing results individually for each load case, the change of stress due to the increasing load increments can be animated instead. To ensure consistent contour values throughout the animation the range of contours is to be specified.

For the final load increment the contour key shows a maximum stress in the order of $7E9$. To create contours of $5E8$ intervals the contour interval needs to be set.

- In the  Treeview double-click on **Contours**. The contour layer properties will be displayed.
- Select the **Appearance** tab and for the **Classic** contour range press the **Set** button.
- Choose the **Interval** option and set the contour interval to be **$5E8$** .
- To ensure a consistent contour key range for all increments that are to be animated, set the **Value to pass through** to be **0**, the **Maximum** to be **$7e9$** , the **Minimum** to be **0** and click **OK**.
- Click the **OK** button to finish.

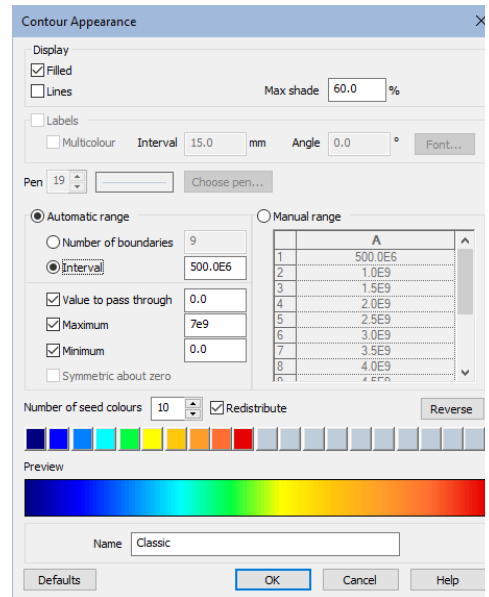

Note. When animating nonlinear loadcases it is important that the deformed mesh is plotted using a factor of 1 and not using a fixed screen size otherwise the deformed mesh for each load increment would be drawn the same. With this in mind:

- In the  Treeview double-click on the **Deformed mesh** layer, select the **Specify Factor** option, enter a factor to **1** and click **OK**

Contact Analysis of a Lug

Tools
Animation Wizard...

- Select the **Load history** option and click the **Next** button.
- A list of all available available load cases for Analysis 1 will appear. Select the **All loadcases** button and the **Finish** button to create an animation for all loadcases and display the animation.

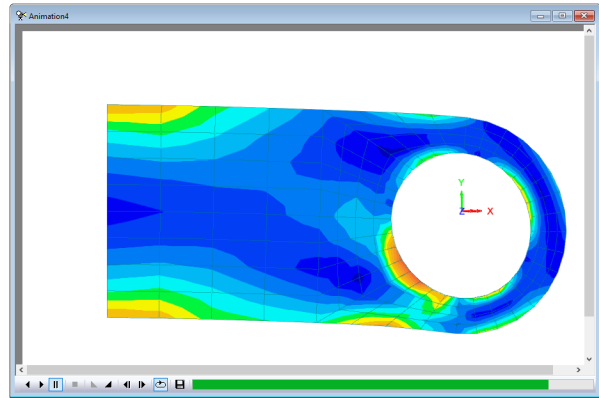

Note. The buttons at the bottom of the window may be used to slow-down, speed-up, pause, step through frame by frame, or stop the animation.

Saving Animations

Animations may be saved for replay in other standard windows animation players.

- Ensure the animation window is the active window.
- Enter **lug_nonlinear** for the animation file name. An **.avi** file extension is automatically appended to the file name when the file is saved.
- Click **OK** to save.
- Delete the animation window and maximise the view window.
- Turn off the display of the Annotation layer in the  Treeview.

File
Save As AVI...

Creating Graphs

Any set of results may be graphed against any other set of results. For example, a graph of resultant displacement for the node at the bottom of the hole of the lug is to be plotted against the load increment.

- Select the node defining the bottom of the hole in the lug.

Utilities

Graph Wizard...

The graph wizard provides a step-by-step means of selecting which results are to be plotted on the X and Y axes of the graph. The X axis is always defined first.

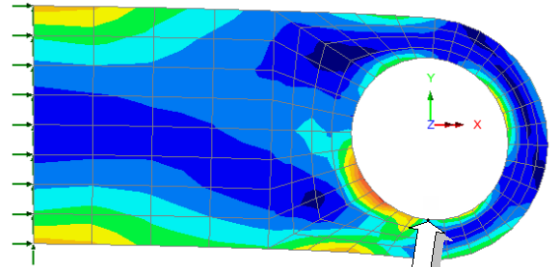

Select this Node

- Ensure the **Time history** option is selected and click the **Next** button.
- Ensure the **Nodal** results button is selected and click the **Next** button.
- Select **Displacement** results for resultant displacement **RSLT**. The node number of the previously selected node will be shown in the Specify node pull-down. Click the **Next** button.

The X axis results have been selected. The Y axis results to be graphed are now defined.

- Select **Named** results and click the **Next** button.
- Select **Total Load Factor** data. Click the **Next** button.

Title information for the graph can be added at this stage.

- Leave all title information blank.
- Click the **Finish** button.

A graph is created in a new window with the values used shown in an adjacent table.

Contact Analysis of a Lug

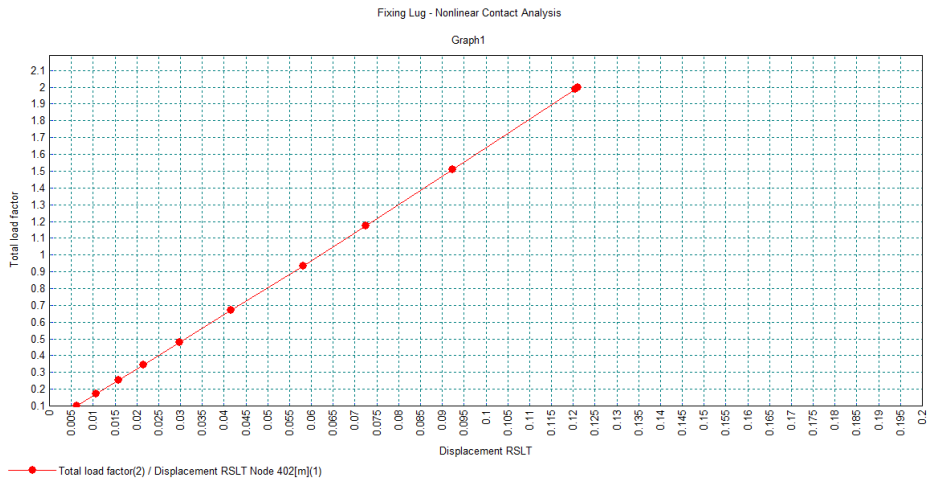





Note. The graph shows a linear displacement history for the node. This is because no geometric nonlinearity has been allowed for in the analysis.

- Close the graph.

Slideline Results

Results can be presented on the contact surfaces as vectors or values, or as a graph on any specified load increment.

- Turn off the **Contours** and **Deformed mesh** layers in the  Treeview.
- Turn on the **Mesh** layer in the  Treeview.
- In the  Treeview select the slideline results group on which the results are to be displayed by right-clicking on the group **Lug_Pin (primary)** and selecting the **Set as Only Visible** option.
- In the  Treeview ensure that the last load increment showing **Load Factor = 2.00000** is active.
- In the  Treeview, turn on the **Values** layer.
- In the properties box, select the Entity **Slideline Results** and the Component **ContPress** to look at results of Contact Pressure.
- Select the **Values Display** tab and ensure that Symbols is not selected, ensure both **Maxima** and **Minima** are selected, set the range to **100 %** and change the number of significant figures to **4**. Click the **OK** button.

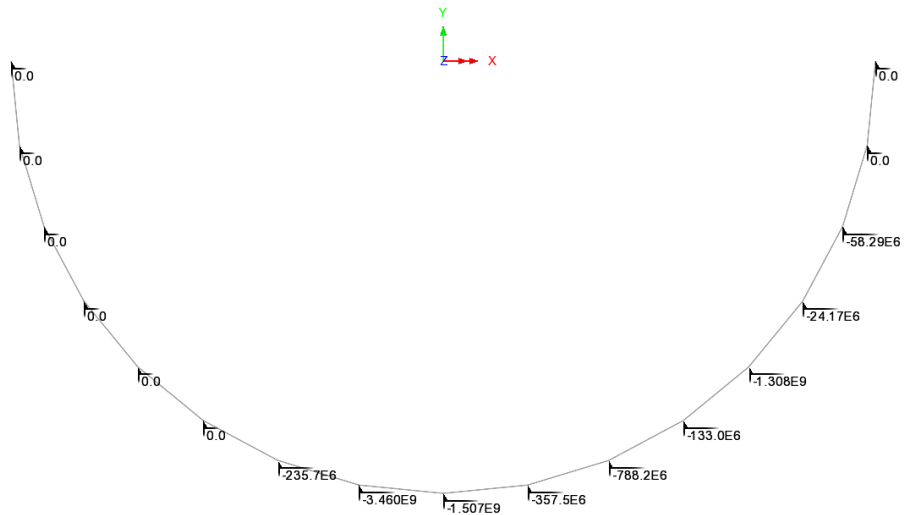

- In the  Treeview, turn on the **Contours** layer.
 - In the properties box, select the Entity **Slideline Results** and the Component **ContPress** to look at contours of Contact Pressure.

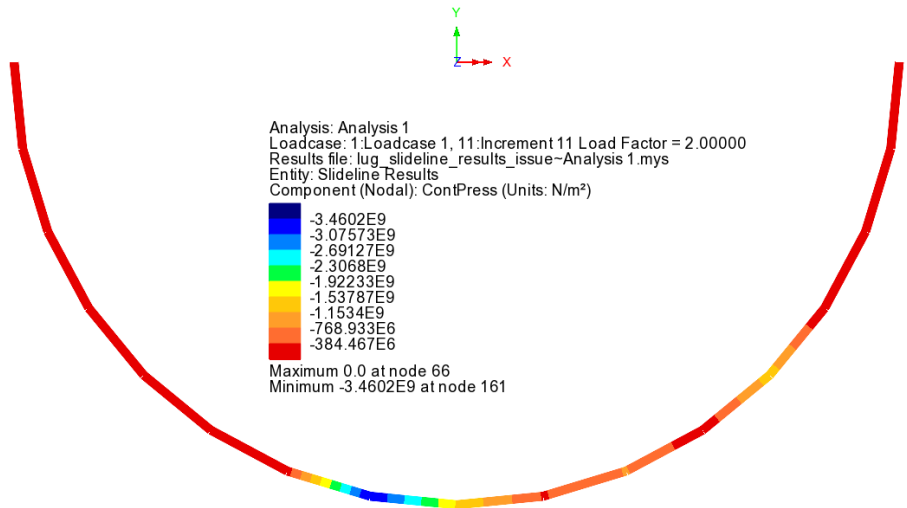

To plot a graph of the contact pressure distribution around the contact surface:

Utilities
Graph Wizard...

- Choose the **Slidelines (assigned to lines)** option and click **Next**
- Select the Component **ContPress**

Contact Analysis of a Lug

- To plot the results against angle rather than length select the **Calculate distance as angle** option.
- Click **Next** followed by **Finish**

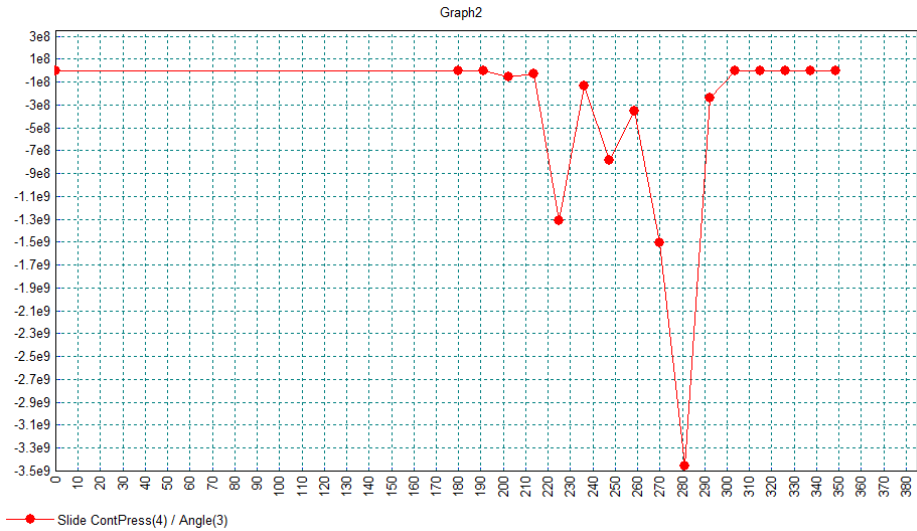

Note. The graph properties and titles may be modified using the right-hand mouse button in the graph window if required.

This completes the nonlinear analysis part of the example.