

Slope stability modelling using Phi- C reduction

For LUSAS version:	24.0
For software product(s):	LUSAS Bridge plus or LUSAS Civil plus
With product option(s):	Geotechnical, Nonlinear

Description

This worked example considers the stability of a slope subject to gravity loading and a load applied to its top surface. The problem is modelled and analysed in 2D.

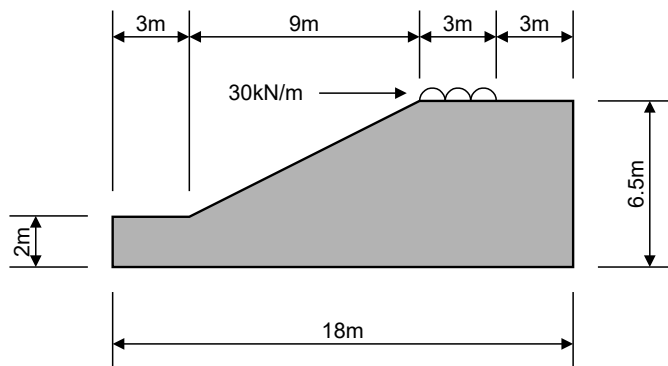

The modelling units used are kN, m, t, s, C throughout.

Objectives

The required output from the analysis consists of:

- Safety factors for each loadcase considered.
- Displacement results plots for each loadcase considered.

Keywords

2D, Inplane, Soil, Geotechnical, Phi-C reduction, (Geostatic) step, Nonlinear, Analysis branch, Safety factors, Displacements.

Associated Files

Associated files can be downloaded from the user area of the LUSAS website.



- ❑ **slope_stability_modelling_2D.lvb** carries out the modelling of the 2D example.

Phi-C Reduction analysis and analysis branches

Phi-c reduction analysis is used to assess soil stability and safety factors for soil that is represented by Mohr-Coulomb or Hoek-Brown material models.

Once it is defined, a 'Phi-c reduction' attribute can be assigned to relevant features in a model for a specified analysis allowing the safety of a slope to be evaluated. Assignment is made to a particular loadcase or analysis stage that defines the applicable loading, boundary conditions and activation status.

By its very nature a Phi-c reduction analysis will always lead to failure, so it is best used in an analysis 'branch' where it can be used to study safety factors independent of the main solution. Analysis branches allow the running of one or more sub-analyses during the solution of a main analysis to investigate the state of the model at a particular loadcase.

Note that the use of phi-c reduction with linear elements can potentially lead to an overestimation of the safety factor.

Modelling

Running LUSAS Modeller

For details of how to run LUSAS Modeller, see the heading *Running LUSAS Modeller* in the *Introduction to LUSAS Worked Examples* document.



Note. This example is written assuming a new LUSAS Modeller session has been started. If continuing from an existing Modeller session select the menu command **File>New** to start a new model file. Modeller will prompt for any unsaved data and display the New Model dialog.

Creating a 2D model

File
New...

- Enter a File name of **Slope_stability_modelling_in_2D**
- Use the default **User-defined** working folder.
- Ensure an Analysis type of **Structural** is set.
- Select an Analysis Category of **2D Inplane**
- Set Model units of **kN,m,t,s,C**
- Ensure the Timescale units are **Days**
- Select a Startup template of **None**.
- Ensure the Layout grid is set as **None**
- Enter a Title of **Slope stability modelling in 2D**
- Click the **OK** button.



Note. Save the model regularly as the example progresses. Use the Undo button to correct any mistakes made since the last save was done.

Defining the Geometry

The soil is modelled as a single surface in the XY plane.

Geometry
Surface >
By Coords...



Enter the coordinates shown in the table to define the 2D cross-section of the slope.

X	Y
0.0	0.0
0	2
3	2
12	6.5
15	6.5
18	6.5
18	0

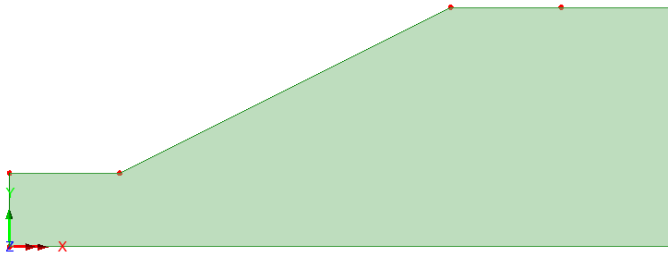

Defining and Assigning Mesh Attributes

- Select **Plane strain**, **Triangle** elements with **Quadratic** interpolation order (TPN6 elements).
- Select **Irregular mesh**, and specify an **Element size of 0.5**
- Enter the attribute name as **TPN6 0.5m** and click **OK**
- Select the Surface representing the soil, and from the  Treeview, drag and drop the **TPN6 0.5m** mesh onto the model.

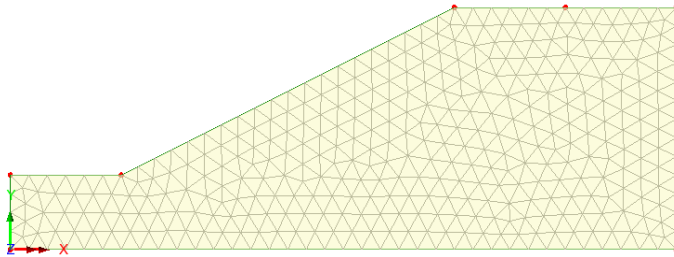

Geometric attributes

No geometric attributes are required.

Material Properties

A plastic material using Modified Mohr-Coulomb (HS) with “no cut-off” is required

- With the **Elastic** tab selected enter a Young’s modulus **2600**, Poisson’s ratio **0.3** and Mass density of **1.63** (Note that this is entered in t/m^3)

Attributes
Mesh >
Surface...

Attributes
Material >
Geotechnical >
Modified Mohr-Coulomb (HS)

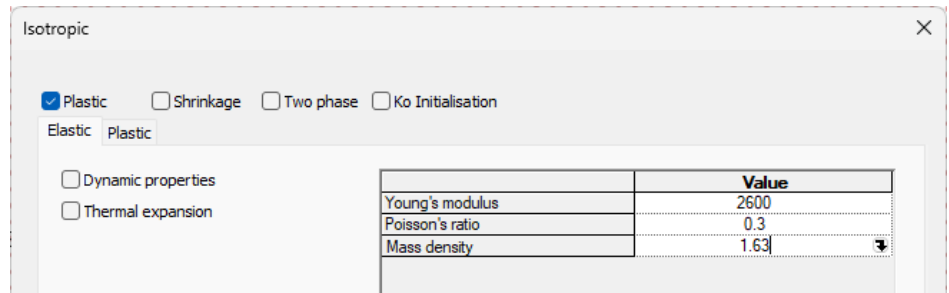

- Select the **Plastic** tab and ensure that the Modified Mohr Coulomb (HS) Type is set to **No cut-off**.
- Enter a Cohesion value of **5**, Friction angle of **20**, and a Dilation angle of **20**.

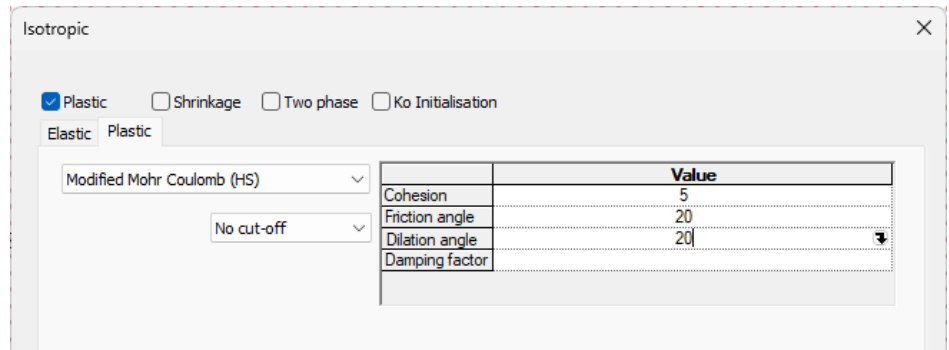

- Enter a material name of **MMC no cut-off** and click **OK**.
- With the whole model selected, drag and drop the material attribute **MMC no-cut-off** onto the selected features, assigning it to **Surfaces** in **Analysis 1**.

Supports

Two support conditions are required: one for the lines at the sides of the model, and one for the line at the bottom of the model.

- Leaving all other degrees of freedom **Free**, set the Translation in X to be **Fixed**. Enter a support name of **Fixed in X** then press **Apply** to define another support.
- Set the Translation in Y to be **Fixed**, change the name to be **Fixed in XY**, and click **OK**.
- Select the lines on the left and right-hand side of the model and drag and drop the support **Fixed in X** onto the selection, assigning it to **Lines** for **Analysis 1**.

Attributes

Support...

Slope stability modelling using Phi-C reduction

- Select the line at the bottom of the model and drag and drop the support **Fixed in XY** onto the selection, assigning it to **Lines** for **Analysis 1**.

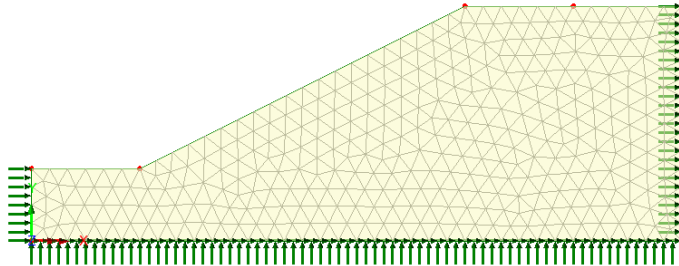

Defining a Phi-c Reduction attribute

A Phi-c reduction attribute will be created in readiness for assignment to the model for a particular loadcase in an analysis branch.

- Enter a starting value for safety factor of **1.1**
- Specify the Minimum change in safety factor to be **0.01**
- Set the Maximum number of steps to use to be **25**.
- Enter a name of **Phi-c1** and click **OK**

This will be assigned to the model later.

Attributes
Phi-c Reduction...

	Value
Starting value for safety factor	1.1
Minimum change in safety factor	0.01
Maximum number of steps to use	25

Name: Phi-c1 (new)

OK Cancel Apply Help

Structural Loading

Gravity loading is required to be assigned to the whole model and a global distributed load is to be defined and assigned to a line on the top surface.

Gravity

The effects of the self-weight of the soil can be applied as a property of an analysis or a loadcase. In this example, gravity will be assigned to individual loadcases where stated.

Defining surface loading (to crest)

- On the structural loading dialog select **Distributed loads** followed by **Global distributed** and click **Next**. Select **Per unit length** and enter a loading value of **-30** in the **Y direction**.

Attributes
Loading...

- Enter a loading name of **Surface loading** and click **Finish**.

Surface loading will be assigned to loadcases in yet to be defined analysis branches.

Modelling methodology

A three stage modelling approach will be taken involving:

1. Setting up the initial conditions for a parent loadcase for two analysis branches
2. Adding an Analysis branch (and loadcase) to investigate the factor of safety from gravity loading only.
3. Adding another Analysis branch (and loadcase) to investigate the factor of safety from gravity loading and a top crest load.

Step1: Setting up a parent loadcase

Supports are already assigned to the parent loadcase, Loadcase 1. Material has already been assigned to the Analysis. Gravity loading and a nonlinear control are also required.

Assigning gravity

- In the  Treeview right-click on **Loadcase 1** and select **Gravity**

Adding a nonlinear control

Phi-c reduction analysis requires a nonlinear control to be set on the parent loadcase.

- In the  Treeview right-click on **Loadcase 1** and from the **Controls** menu item select the **Nonlinear & Transient** option.

Nonlinear & Transient

Nonlinear

Incrementation: Manual

Starting load factor: 0.1

Max change in load factor: 0.0

Max total load factor: 1.0

Adjust load based on convergence

Iterations per increment: 4

Time domain

Time domain: Two Phase

Initial time step: 0.0

Total response time: 100.0E6

Automatic time stepping

Solution strategy

Same as previous loadcase

Max number of iterations: 12

Residual force norm: 0.1

Displacement norm: 0.1

Incremental LUSAS file output

Same as previous loadcase

Output file: 1

Plot file: 1

Restart file: 0

Max number of saved restarts: 0

Log file: 1

History file: 1



Save a restart at the end of this control

Common to all

Max time steps or increments: 0

OK Cancel Help

- In the Nonlinear & Transient dialog select the **Nonlinear** option in the top-left hand corner and set the Incrementation type to be **Manual**.
- Click **OK**.

A  Nonlinear and Transient entry will be added to the  Treeview. Double-clicking on this entry will allow any future changes to be made to the control properties.

Geostatic state

Most geotechnical problems begin from a geostatic state. This represents the initial stress distribution where the undisturbed soil or rock body remains in equilibrium with the prescribed boundary conditions and geostatic loads, including self-weight, or overburden, producing zero deformations. This stress state is then used as the initial stress field in a subsequent static or coupled pore fluid diffusion/stress analysis.

Reset Deformation

A 'Reset Deformation' attribute is to be assigned to the elements in the model to return the model to its undeformed shape.

- Ensure that **Elements** is selected (this will reset nodal coordinates and element strains), accept the default name and click **OK**.

Attributes
Reset Deformation...

- Press the **Ctrl+A** keys to select the whole model, then from the  Treeview, drag and drop the Reset Deformation attribute **RstDfm1** onto the selected features.

Analysis branches

Analysis branches allow the running of one or more sub-analyses during the solution of a main analysis to investigate the state of the model at a particular loadcase. Analysis branches can be added to the  Treeview for any loadcase in that treeview that has (or inherits) a nonlinear or transient control.

For this example, two analysis branches are required – one to assess safety factors for gravity only loading, and one to assess factors for gravity and surface loading.

Step 2: Adding an analysis branch for the ‘gravity only’ assessment

- In the  Treeview right-click on the **Loadcase 1** and from the **New** menu item select the **Branch** option, then select a branch type of **Phi-c Reduction**, enter an analysis name of **Branch 1 gravity only** and click **OK**.

Assign the Phi-C reduction attribute



Note. A Phi-c reduction analysis always leads to failure, so it can be termed an analysis “dead-end”. As a result a Phi-c reduction attribute should generally be assigned to an analysis branch (and not to a main analysis entry) so that if a model contains multiple analyses the Phi-c reduction analysis will not prevent those other analyses from being solved.

- Select the whole model (press the **Ctrl + A** keys together), and from the  Treeview drag and drop the Phi-c reduction attribute **Phi-c1** onto the selected features, assigning it to **Surfaces** for analysis **Branch 1 gravity only** and **Loadcase 2**, and click **OK**.

Assigning gravity

- In the  Treeview right-click on **Loadcase 2** and select **Gravity**

Adding a Nonlinear Control

Phi-c reduction analysis requires a nonlinear control to be set on the loadcase to which it has been assigned.

- In the  Treeview right-click on **Loadcase 2** and select the **Nonlinear & Transient** option from the **Controls** menu.

Slope stability modelling using Phi-C reduction

- In the Nonlinear & Transient dialog select the **Nonlinear** option in the top-left hand corner and set the Incrementation type to be **Manual**. No other settings are required for this example. Click **OK**.

The Analyses Treeview should look like this:

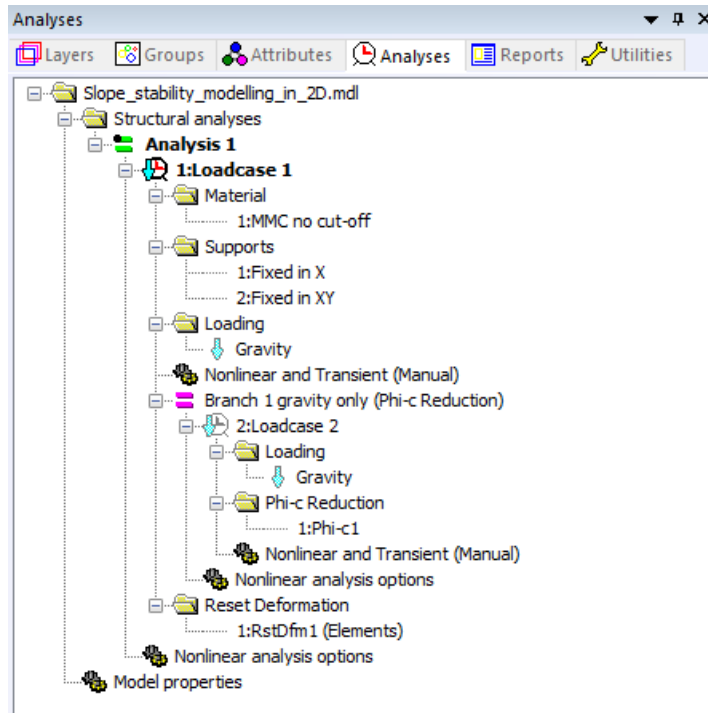

Step 3: Adding an analysis branch for the 'gravity and top load' assessment

- In the Treeview right-click on the **Loadcase 1** and from the **New** menu item select the **Branch** option, then select a branch type of **Phi-c Reduction**, change (by typing) the analysis name to be **Branch 2 gravity and surface load** and click **OK**. An analysis entry will be added to the Treeview along with Loadcase 3.



Note. Analysis branch names are sorted alphabetically. Each analysis branch is an independent sub-analysis, and not reliant on results from other branches. If more than one analysis branch is defined for a parent loadcase, all occur simultaneously, not sequentially.

Assigning surface loading

- Select the left-most line on the crest of the model and from the  Treeview drag and drop the loading attribute **Surface loading** onto the selected line, assigning it to **Lines** for analysis **Branch 2 gravity and surface load** and **Loadcase 3**, and click **OK**.

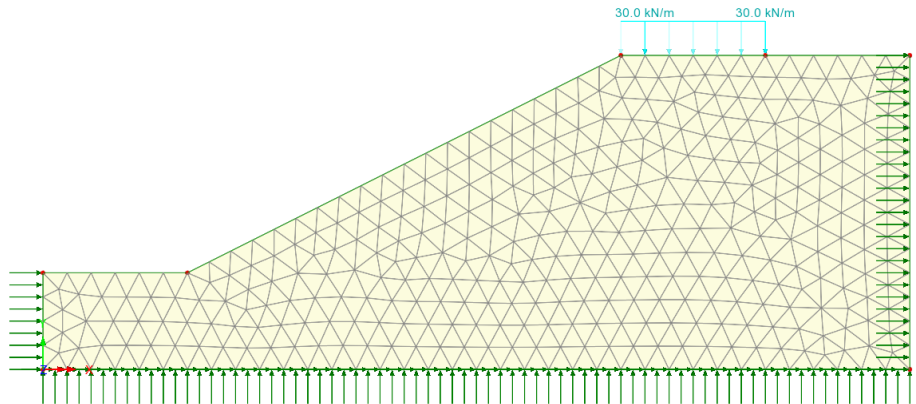

Assign the Phi-C reduction attribute

- Select the whole model (press the **Ctrl + A** keys together), and from the  Treeview drag and drop the Phi-c reduction attribute **Phi-c1** onto the selected features, assigning it to **Surfaces** for analysis **Branch 2 gravity and surface load** and **Loadcase 3**, and click **OK**.



Assigning gravity

- In the  Treeview right-click on **Loadcase 3** and select **Gravity**

Adding a Nonlinear Control

As stated previously, Phi-c reduction analysis requires a nonlinear control to be set on the loadcase to which it has been applied.

- In the  Treeview right-click on **Loadcase 3** and select the **Nonlinear & Transient** option from the **Controls** menu.
- In the Nonlinear & Transient dialog select the **Nonlinear** option in the top-left hand corner and set the Incrementation type to be **Manual**. No other settings are required for this example. Click **OK**.

A  Nonlinear and Transient entry will be added to the  Treeview.

The  Treeview should now look like this:

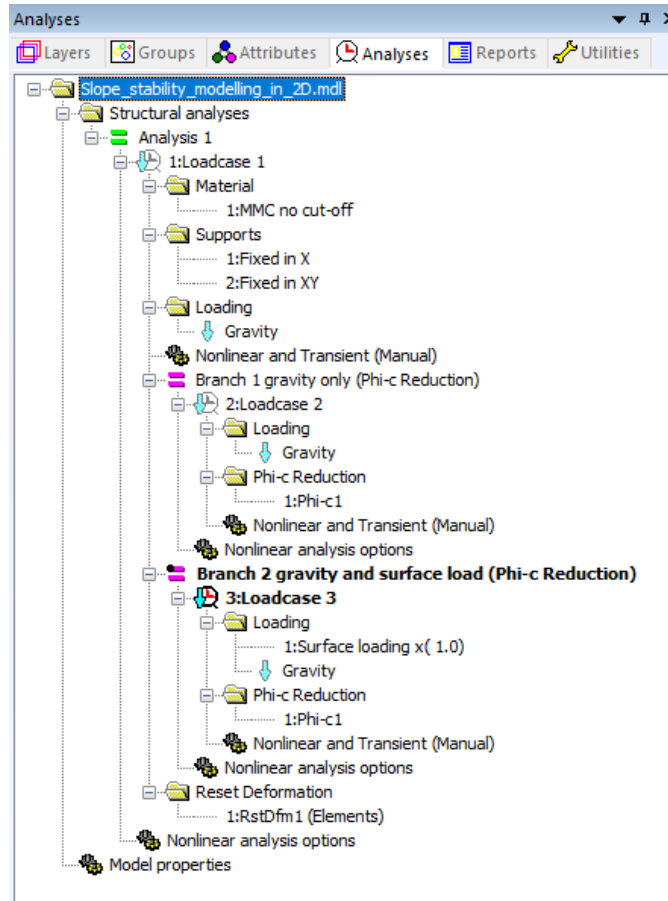

Nonlinear controls – Use Manual or Automatic?

Essentially:

- Defining ‘Manual’ incrementation requires the total loading within the loadcase for which the nonlinear control has been specified, to be defined.
- Defining ‘Automatic’ incrementation requires only the extra loading within the loadcase to be defined, because other loading that was specified in a previous loadcase with Manual incrementation will be inherited.

The following flow chart can be used to decide if Manual or Automatic incrementation controls need to be defined for a nonlinear loadcase. Use total loads in each nonlinear step.

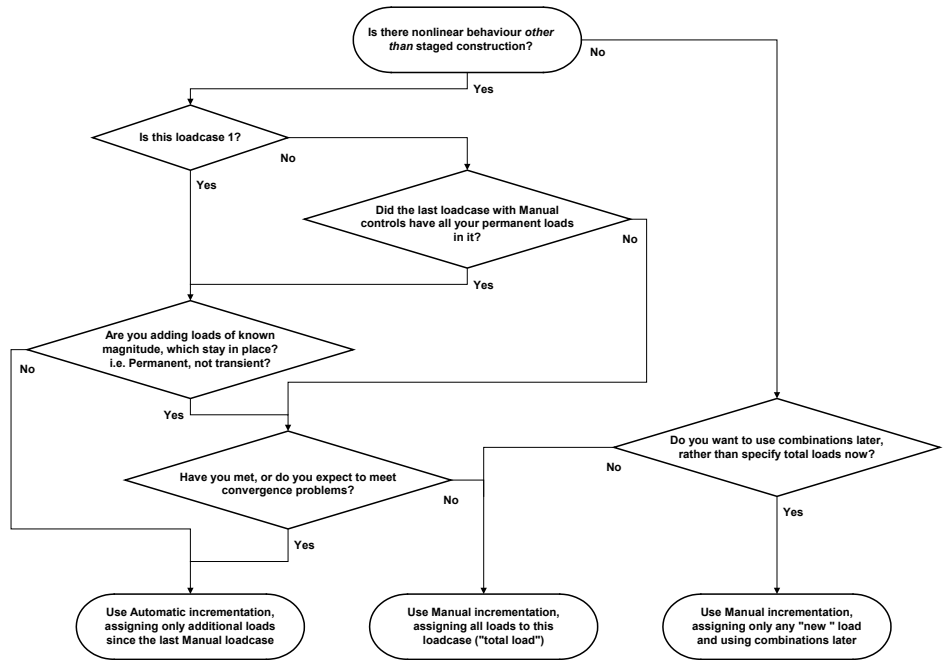

Flow chart to determine whether to use Manual or Automatic nonlinear loadcase control.

Running the Analysis



Open the Solve Now dialog, ensure **Analysis 1** is selected and press **OK** to solve.

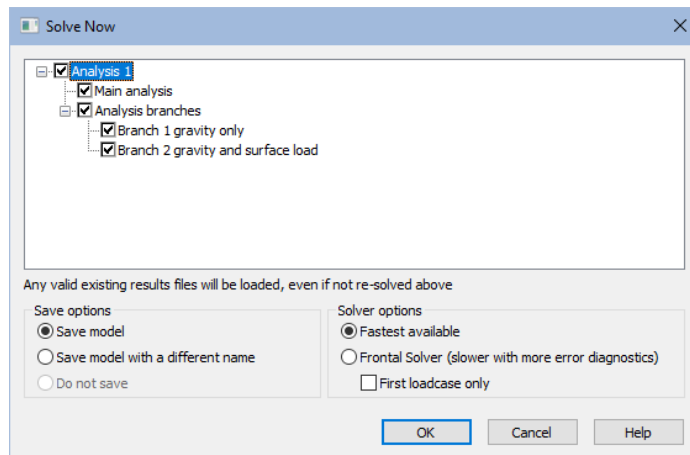

Slope stability modelling using Phi-C reduction

A LUSAS Datafile will be created from the model information. The LUSAS Solver uses this datafile to perform the analysis.

If the analysis is successful...

Analysis loadcase results are added to the  Treeview.

In addition, these files will be created in the LUSASFiles\<<model_name> folder:



- slope_stability_modelling_in_2D.dat** this data file contains details of model data and assigned attributes.
- slope_stability_modelling_in_2D.out** this output file contains details of model data, assigned attributes and selected statistics of the analysis.
- slope_stability_modelling_in_2D.mys** this is the LUSAS results file from the analysis which is loaded automatically into the  Treeview to allow results to be viewed.

If the analysis fails...

If the analysis fails, information relating to the nature of the error encountered is written to the output files in addition to the text output window. Any errors listed in the text output window should be corrected in LUSAS Modeller before saving the model and re-running the analysis.

Rebuilding the Model

If errors are listed that for some reason cannot be corrected, a file is provided to re-create the model information correctly, allowing a subsequent analysis to be run successfully. You may download this associated file from the user area of the LUSAS website.



Slope_stability_modelling_2D.lvb this carries out the modelling of the example.

File
New...



Start a new model file. If an existing model is open Modeller will prompt for unsaved data to be saved before opening the new file.

- Enter the file name as **slope_stability_modelling_in_2D**
- Use the default **User-defined** working folder.
- Ensure an Analysis type of **2D Inplane** is set.
- Click the **OK** button.



Note. There is no need to enter any other new model details when a script is run to build a model, since the contents of the script will overwrite any other settings made.

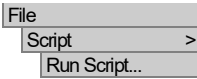

To recreate the model, select the file **slope_stability_modelling_2d.lvb** that was downloaded and placed in a folder of your choosing.



Solve the analysis to generate the results.

Viewing the Results

Following a successful solve, analysis loadcase results for each nonlinear analysis increment are present in the  Treeview. A deformed mesh layer will be automatically added with a 6mm screen size deformation. The deformed mesh for the last loadcase solved will be shown.

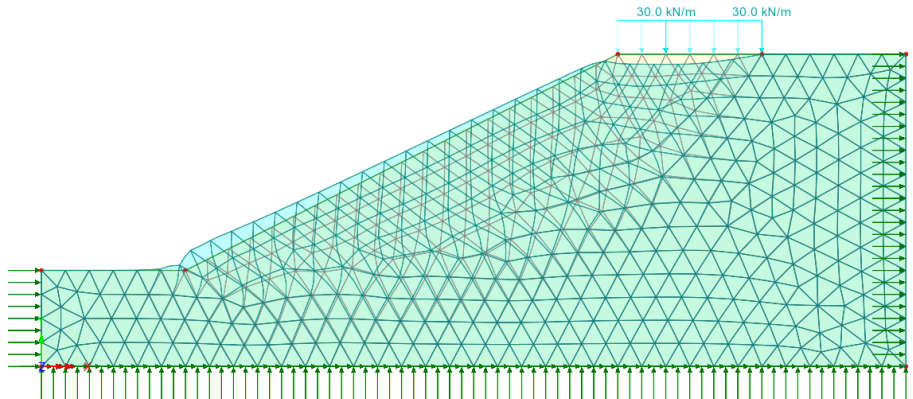

Viewing safety factors

From an initial inspection of the increments in the  Treeview it can be seen from using the default nonlinear control settings:

- The safety factor for the gravity-only assessment is **1.568**
- The safety factor for the gravity and surface loading assessment is **1.235**

Viewing results

- In the  Treeview turn-off the display of the **Mesh** and **Geometry** and **Attributes** layers.

Gravity loading only

- In the  Treeview, set active **Loadcase 2** (found inside Analysis branch 1). The last load increment for this loadcase will be set active.
- Right-click in a blank region of the view window and add the **Contours**. Then, on the contour properties dialog, select entity **Displacement** and component **RSLT** and click **OK**.

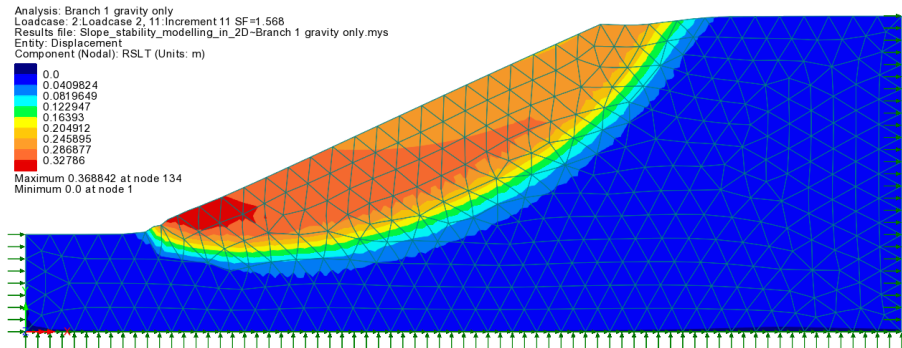

Gravity and surface loading

- In the  Treeview, set active **Loadcase 3** (inside Analysis branch 2). The last load increment for this loadcase will be set active.

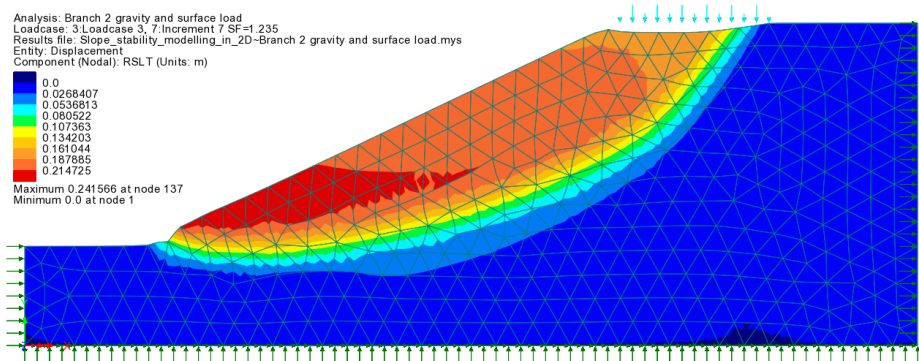

Note. Whilst viewing a deformed mesh with a maximum on-screen displacement value provides a visual indication of soil displacement, it can be misleading when it is compared to the displacement value stated in the contour key. A deformed mesh factor of 1 can be used to ensure that displacements seen on screen match the values reported.

- In the  Treeview double-click the **Deformed mesh** layer, then click the **Specify factor** radio button and enter a value of 1.

This then updates the view to show the real (undrawable) result of reaching this load factor.

- By setting active the individual increments within loadcase 3 in turn the initial loading, resetting and progressive increasing of the safety factor and subsequent failure of the slope can be seen.





Note. When viewing a ‘Reset Deformation’ loadcase, setting a scale factor to be 1 (rather than using an on-screen value) will avoid a misleading mesh pattern that is caused by infinitesimal displacements being magnified by the default mesh factor.

This completes the example.

Discussion

Slope stability modelling using Phi-c reduction can be carried out in 3D in a similar manner to that done in 2D provided an analysis category of 3D is set either when creating a new model initially, or when converting a 2D model into a 3D model.

If the latter is done note that all assignments made for the 2D model that are no longer valid will be marked with an invalid data  symbol, and these will need to be unassigned as necessary and replaced with assignments that are suitable for the 3D model.

A 3D model that was generated from the 2D worked example model for comparison purposes is shown below. Its associated Analyses  treeview is shown for reference.

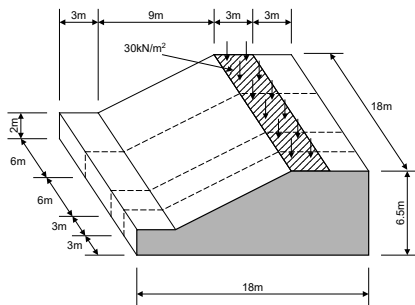

3D modelling details

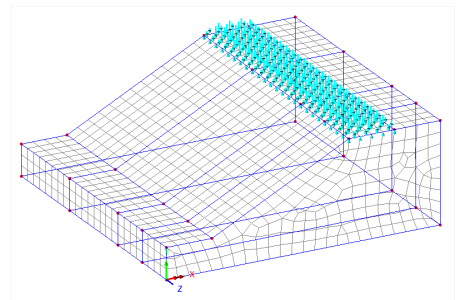

3D model with assigned loading

